

[1610.01 Introduction](#)
[1610.02 Barrier Impacts](#)
[1610.03 General Barrier Design](#)
[1610.04 Beam Guardrail](#)
[1610.05 High-Tension Cable Barrier](#)
[1610.06 Concrete Barrier](#)
[1610.07 Bridge Traffic Barriers](#)
[1610.08 Other Barriers](#)
[1610.09 References](#)

[Exhibit 1610-1 Concrete Barrier Placement Guidance: Assessing Impacts to Wildlife](#)
[Exhibit 1610-2 Traffic Barrier Locations on Slopes](#)
[Exhibit 1610-3 Longitudinal Barrier Deflection](#)
[Exhibit 1610-4 Barrier Standard Run Minimum/Maximum Lengths](#)
[Exhibit 1610-5 Longitudinal Barrier Flare Rates](#)
[Exhibit 1610-6 Barrier Length of Need on Tangent Sections](#)

[Exhibit 1610-7 Barrier Length of Need](#)
[Exhibit 1610-8 Barrier Length of Need on Curves](#)
[Exhibit 1610-9 Beam Guardrail Trailing End Placement for Divided Highways](#)
[Exhibit 1610-10 Beam Guardrail Post Installation](#)
[Exhibit 1610-11 Guardrail Connections](#)
[Exhibit 1610-12 Transitions and Connections](#)
[Exhibit 1610-13 Median Cable Barrier Placement](#)
[Exhibit 1610-14 Roadside Cable Barrier Placement](#)
[Exhibit 1610-15 Cable Barrier Placement: Overlap on Divided Highways](#)
[Exhibit 1610-16 Cable Barrier Placement: Cable Barrier Termination/Overlap with Beam Guardrail](#)
[Exhibit 1610-17 Concrete Barrier Shapes](#)
[Exhibit 1610-18 Single-Slope Barrier Placement – In Front of Fill Slope \(New 2024\)](#)
[Exhibit 1610-19 Type 7 Bridge Rail Upgrade Criteria](#)
[Exhibit 1610-20 Thrie Beam Rail Retrofit Criteria](#)

Chapter Organization: Sections [1610.01](#) Introduction and [1610.02](#) Barrier Impacts present information to consider when deciding whether or not to install a barrier. Section [1610.03](#) General Barrier Design contains guidance common to **ALL** barrier types; such as deflection distance, minimum/maximum system lengths, length of need, and sight distance. The remaining sections, [1610.04](#) through [1610.08](#), present design information organized by specific barrier type (beam guardrail, cable barrier, concrete barrier, bridge traffic barrier, and other barriers).

Refer to the [Glossary of Terms](#) for many of the terms used in this chapter.

Refer to [Chapter 300](#) and Section [1610.01\(1\)](#) for design documentation requirements.

1610.01 Introduction

WSDOT uses traffic barriers to reduce the overall severity of crashes. Consideration is given as to whether a barrier is preferable to the recovery area it may replace. In some cases, installation of a traffic barrier may result in more crashes as it's an object that can be struck. Barriers are designed so that such encounters might be less severe and not lead to secondary or tertiary crashes. However, traffic barriers are not guaranteed to redirect an impacting vehicle without resulting injury to its occupants or triggering additional crashes. Barrier performance is affected by the characteristics of the vehicles that collide with them. Different vehicles will react differently given the characteristics and dynamics of the crash. Therefore, vehicles will be decelerated and redirected differently given the size, weight and direction of force imparted from the vehicle to the barrier.

Barriers are not placed with the assumption that the system will restrain or redirect all vehicles in all conditions. It is recognized that the designer cannot design a system that will address every potential crash situation. Instead, barriers are placed with the assumption that, under typical crash conditions, they might decrease the potential for excessive vehicular deceleration or excessive vehicle redirection when compared to the location without the barrier.

Traffic barriers do not prevent crashes or injuries from occurring. They often lower the potential severity for crash outcomes. Consequently, barriers should not be used unless a reduced crash severity potential is likely. No matter how well a barrier system is designed, optimal performance is dependent on drivers' proper maintenance and operation of their vehicles and the proper use of passenger restraint systems. Site constraints play a major role in decisions regarding barrier selection and placement.

Depending on the location, these constraints may include environmental considerations, topographic challenges, restricted right-of-way, geologic concerns, or conflicts with other infrastructure.

Barrier systems and vehicle fleets continue to evolve. The choice of a barrier is based on the characteristics of today's vehicle fleet and testing criteria, not on speculative assumptions of future vehicle designs. This continuum of change does not allow engineers to predict the future with any degree of certainty. Consequently, engineering decisions need to be made based on the most reliable and current information.

Engineers are constantly striving to develop more effective design features to improve highway safety. However, economics, asset management and maintenance needs, and feasibility do not permit the deployment of new designs as soon as they become available on the market or are invented by a manufacturer. Further, most new designs only make marginal changes to systems and do not imply that old designs are unsafe or need modification.

Solutions may consider crash frequency and severity. As discussed previously, performance of the system relies on the interaction of the vehicle, driver, and system design at any given location. Additionally, the ability to safely access, maintain and operate over time is incorporated into the final barrier decision.

When barriers are crash-tested, it is impossible to replicate the innumerable variations in highway conditions under which the barrier applications occur. Therefore, barriers are crash-tested under standardized conditions. These standard conditions were previously documented in National Cooperative Highway Research Program (NCHRP) Reports 230 and 350. These guidelines have been updated and are now presented in the AASHTO publication, *Manual for Assessing Safety Hardware (MASH)*.

Roadside safety hardware (barriers, devices, etc.) are accepted for use by WSDOT following a review of its performance with respect to a crash testing standard. Documented evidence of performance includes, but is not limited to, crash testing results, a comparison to similar crash tested designs, or an engineering analysis of the system and/or its components. Following a successful review, the device is then considered "compliant" with the applicable standard (e.g., MASH-compliant).

The latest roadside safety hardware standard (MASH) is being implemented by WSDOT product category. Implementation takes place as designs and products are reviewed by WSDOT, determined to be MASH-compliant, and accepted for use. Following acceptance, implementation is documented through modifications to the corresponding standard specification(s), standard plan(s), and/or are accepted to the Qualified Products List (in the case of proprietary hardware). The policy on work zone devices is described in Chapter 1010.

To learn more about MASH implementation at WSDOT see the following website: [Roadside safety | WSDOT \(wa.gov\)](https://www.wa.gov/roadside-safety)

1610.01(1) Documentation

Document barrier location decisions, including any site constraints encountered that influenced those decisions. A decision to install barrier using criteria outside the guidance provided in this chapter requires a Design Analysis, unless otherwise directed by the ASDE.

1610.02 Barrier Impacts

Engineering judgment is required in determining the appropriate placement of barrier systems, therefore consider the location of the system and the possible impacts the barrier may have to other highway objectives.

1610.02(1) Assessing Impacts to Stormwater and Wetlands

The presence of stormwater facilities or wetlands influence the choice and use of barrier systems. For example, the placement of concrete barrier may increase the amount of impervious surface, which could then result in retrofit or reconstruction of the existing retention/detention systems and environmental impact requirements and studies. Assess whether concrete barrier or beam guardrail placement will cause the need for an evaluation by the HQ Environmental Services Office. Conduct this evaluation early in the project’s development process to allow adequate time for discussion of options.

1610.02(2) Assessing Impacts to Wildlife

The placement of concrete barriers in locations where wildlife frequently crosses the highway can influence wildlife-vehicle crash potential. When wildlife encounters physical barriers that are difficult to see beyond or cross, such as concrete barriers, they often stop or move parallel to those barriers, increasing their time on the highway and their exposure.

Traffic-related wildlife mortality may play a role in the decline of some species listed under the Endangered Species Act. To address wildlife concerns, see [Exhibit 1610-1](#) to assess whether barrier placement needs to have an evaluation by the HQ Environmental Services Office to determine its effect on wildlife. Conduct this evaluation early in the project development process to allow adequate time for discussion of options.

Exhibit 1610-1 Concrete Barrier Placement Guidance: Assessing Impacts to Wildlife

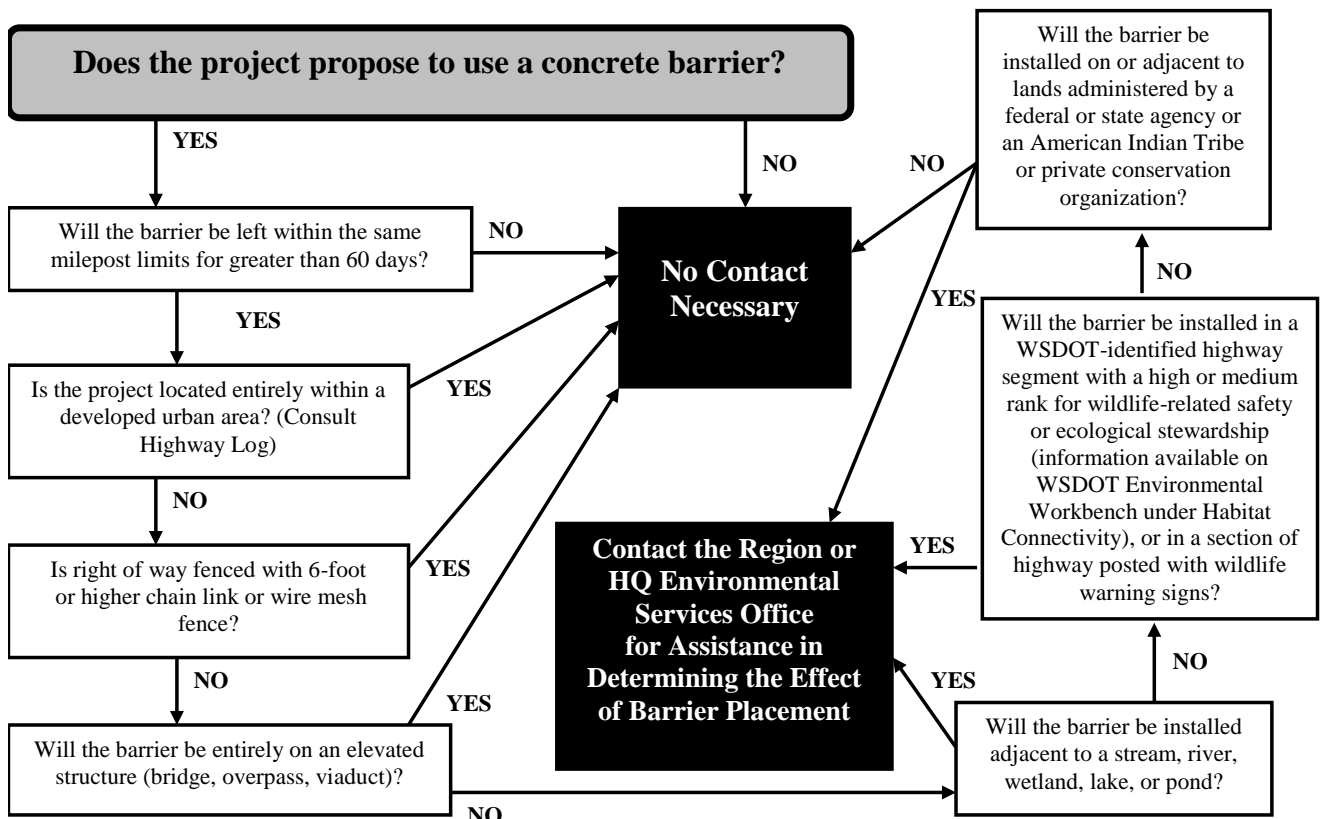

1610.03 General Barrier Design

Apply the policy and guidance in this chapter when directed to do so in [Exhibit 1105-1](#), and following an examination of the potential alternative mitigation measures described in Section [1600.01](#).

[Chapter 1120](#) identifies those elements and features to be evaluated and potentially addressed during the course of many Preservation projects (see [Exhibit 1105-1](#)).

Once the use of a barrier has been selected as the mitigation measure for a condition, select a particular barrier type by considering the barrier system's deflection characteristics, cost, maintainability and impacts to traffic flow during repair. Barriers are categorized as flexible, semi-rigid, or rigid depending on their deflection characteristics (see [Exhibit 1610-3](#)). Barrier types include:

- Beam Guardrail
- Cable Barrier
- Concrete Barrier
- Bridge Traffic Barrier
- Other Barriers

1610.03(1) New Roadside Safety Hardware

Since non-rigid systems typically sustain more damage during an impact, consider the amount of traffic exposure maintenance crews might incur with the more frequent need for repairs.

The costs for procuring and maintaining the barrier system are important factors when considering what system to install. Considerations may include:

- Consultation with the Area Maintenance Superintendent to identify needs or recommendations.
- Drainage, alignment, and drifting snow or sand are considerations that can influence the selection of barrier type. Beam guardrail and concrete barrier can contribute to snow drifts. Consider long-term maintenance costs associated with snow removal at locations prone to snow drifting. Cable barrier is not an obstruction to drifting snow.
- Analysis of potential reduction of sight distance due to barrier selection and placement.
- Additional widening and earthwork requirements. With some systems, such as concrete barrier and beam guardrail, the need for additional shoulder widening or slope flattening is common. Selection of these types of barriers may require substantial environmental permitting or roadway reconstruction. Permits issued under the SEPA and NEPA processes may lead to the use of a barrier design, such as cable barrier, which has fewer potential environmental impacts and costs.
- For concrete barrier systems:
 - Lower maintenance costs than for other barrier types.
 - Deterioration due to weather and vehicle impacts is less than most other barrier systems.
 - Unanchored precast concrete barrier can usually be realigned or repaired after a vehicle impact. However, heavy equipment may be necessary to reposition or replace barrier segments. Therefore, in medians, consider the shoulder width and the traffic volume when determining the acceptability of unanchored precast concrete barrier versus rigid concrete barrier. See [Exhibit 1610-3](#) for deflection area requirements.

1610.03(2) Existing Roadside Safety Hardware

When directed in [Exhibit 1105-1](#) to apply the policy and guidance in this chapter, evaluate the need to upgrade existing roadside safety hardware to a MASH-compliant product or design. Consider the standard to which the existing barrier or device was originally designed and tested: MASH, NCHRP 350, and pre-NCHRP 350. The decision to replace existing hardware that is not MASH-compliant is based on the project type as follows:

- All projects directed to use this chapter in [Exhibit 1105-1](#) are required to replace pre-NCHRP 350 hardware, except for breakaway cable (guardrail) terminals, which have their own independent replacement program.
- In addition, all improvement and preservation projects directed to use this chapter in [Exhibit 1105-1](#) may leave in place existing NCHRP 350 compliant hardware that is still in serviceable condition, or alternatively may relocate it within the project limits. Note that NCHRP 350 hardware found to be in serviceable condition that is temporarily moved as part of work zone activity may also be reinstalled in its original location without the need to upgrade. See Sections [1610.03\(2\)\(a\)](#), [1610.03\(2\)\(b\)](#), and [1610.03\(2\)\(c\)](#) to determine if existing roadside safety hardware is in serviceable condition. See Section [1610.04\(1\)\(b\)](#) when placing new fixed objects behind existing Type 1 guardrail.
- See Section [1610.04\(5\)](#) for additional evaluation instructions for beam guardrail terminals.

See [Chapter 1120](#) for additional policy on addressing existing roadside safety hardware in Preservation projects.

When leaving existing barrier in place per the direction above, confirm that the configuration and layout (height, length, offset, etc.) are according to the original standard, and correct if necessary.

Consult with your ASDE for more information and for the latest guidance on documenting the decision to replace or not replace NCHRP 350 hardware on a project.

1610.03(2)(a) Guardrail and Guardrail Terminal Condition

Examine guardrail condition using the procedure and metrics in the WSDOT publication “Field Guide for Guardrail Condition Assessment,” which is found on the [Roadside Safety](#) webpage. Establish and record the specific locations that match damage classes Medium and High as described in the guide and provide a replacement or repair of the hardware at those locations as part of the project. For replacement of sections in Type 1 guardrail runs involving six or more (75-feet or more) adjacent rail panels or posts and hardware associated with the adjacent panels, replace the damaged length with Type 31 guardrail components including adaptor sections to the rest of the run (see [Std Plans C-20.10](#) and [C-25.80](#)). When the rail damage is within 100 feet of the end of a run, replace the end of the run and upgrade the terminal if it is not MASH compliant per Section [1610.04\(5\)](#).

1610.03(2)(b) Concrete Barrier Condition

Examine the condition of the concrete barrier with respect to the following criteria.

- Replace concrete barrier having one or more of the listed issues:
 - One or more cracks that penetrate through the entire section.
 - One or more spalls in the concrete with a depth of greater than 1.5 inches.
 - Exposed rebar or bolts that are protruding through the barrier surface.
 - Cracked or broken concrete that could be easily dislodged if struck by a vehicle.
 - End connection hardware that is deformed, bent, broken, corroded/rusted, or no longer functional.

- Concrete barrier does not need to be replaced when having one or more of the following:
 - Only minor blemishes (e.g., dirt, scuffs, traffic marks, superficial surface cracking, etc.).
 - Cracks or chips less than 1/2 inch deep.
 - Spalls in the concrete with a depth less than 1.5 inches.
 - End connection hardware that is intact, undamaged, and functional.

1610.03(2)(c) Other Roadside Safety Device Condition

Replace other types of roadside safety devices not discussed in Sections [1610.03\(2\)\(a\)](#) or [1610.03\(2\)\(b\)](#) which the responsible maintenance superintendent has identified as “unable to be serviced or repaired” (e.g., impact attenuators, inertial sand barrels, etc.). It is permissible not to replace roadside safety devices if they are functional and are:

- being addressed in an upcoming funded or programmed project, or
- already being addressed by maintenance activities.

Consult with your ASDE when not replacing a roadside safety device for any other reason.

1610.03(3) Barrier Placement

Proper installation of a barrier system is required for the system to perform similar to the crash tests that resulted in its acceptance for use on our highways. Maximize the distance between the barrier and the travelled way.

See [Chapter 1239](#) for minimum lateral clearance requirements.

1610.03(3)(a) Placement on a Slope

Slopes may affect barrier placement. Considerations for barrier placement on a slope include:

- For slopes that are 10:1 or flatter, concrete barrier, beam guardrail or cable barrier can be installed anywhere beyond the edge of shoulder. See [Exhibit 1610-2](#).
- For additional placement guidance see Section [1610.05\(1\)](#) for cable barrier, see Section [1610.04\(2\)](#) for beam guardrail, and see Section [1610.06](#) for concrete barrier.

Exhibit 1610-2 Traffic Barrier Locations on Slopes

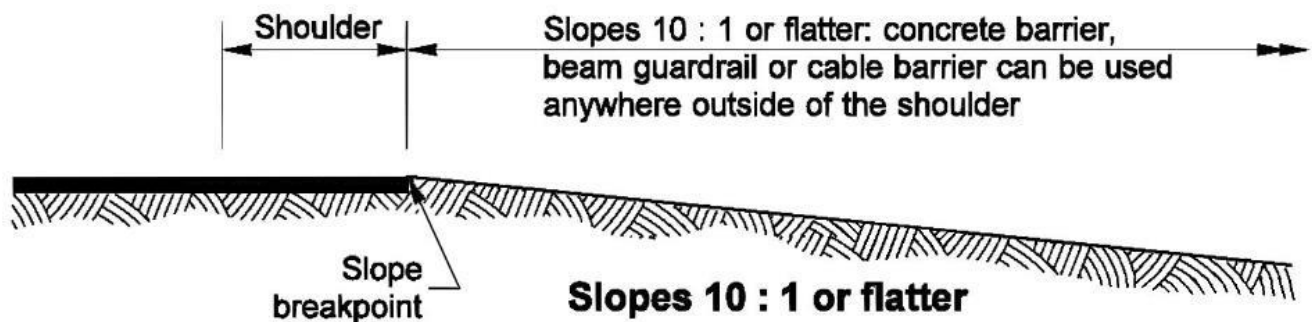

1610.03(3)(b) Placement in Median Locations

The following barrier types may be used in medians in new installations:

- Cast in place double-sided, single-slope, concrete barrier
- Precast double-sided single-slope concrete barrier
- Pinned F-shape double-sided concrete barrier
- Unpinned F-shape double-sided concrete barrier
- Type 31 w-beam guardrail
- Double-sided Type 31 w-beam guardrail
- High-tension cable barrier

Select the appropriate barrier type using the following criteria:

- Contact HQ Design when retrofitting non-freeways with median barrier (regardless of median width).
- Address the design deflection characteristics of the barrier to avoid placement of barrier where the design deflection extends into oncoming traffic.
- Barrier may be provided under certain conditions as separation between a freeway mainline and collector-distributor road (see [Chapter 1360](#)).
- When W-beam barrier is placed in a median as a countermeasure for cross-median crashes, design the barrier to be struck from either direction of travel. For example, the installation of beam guardrail might be double-sided (Type 31-DS).
- Narrow medians provide little space for any maintenance activities, including repair or repositioning of the barrier. Installing barriers in medians that provide less than 8 feet from the edge of the traveled way to the face of the barrier will likely require temporarily closing the adjacent lane during maintenance activities. This will impact the travelling public and impact maintenance staff, and maintenance staff should be consulted. See [Chapter 301](#) Design and Maintenance Coordination.
- Use single slope high performance concrete barrier (HP barrier) on freeways with medians 22-feet wide and less.
- Any barrier type listed above may be used on freeways with medians greater than 22-feet wide.
- In general, cable barrier is recommended with medians that are 30 feet or wider. However, cable barrier may be appropriate for narrower medians if adequate deflection distance exists.
- In wider medians, the selection and placement of barrier might depend on the slopes in the median. At locations where the median slopes are relatively flat (10H:1V or flatter), unrestrained precast concrete barrier, beam guardrail, and cable barrier can be used depending on the available deflection distance. At these locations, position the barrier as close to the center of the median as possible so that the recovery distance can be maximized for both directions. There may be a need to offset the barrier from the flow line to avoid impacts to the drainage flow.
- At locations where the roadways are on independent alignments and there is a difference in elevation between the roadways, the slope from the upper roadway might be steeper than 6H:1V. In these locations, position the median barrier along the upper roadway and provide deflection and offset distance as discussed previously. Barrier is generally not needed along the lower roadway except where there are fixed features in the median.

For additional placement guidance see Section [1610.05\(1\)](#) for cable barrier, see Section [1610.04\(2\)](#) for beam guardrail, and see Section [1610.06](#) for concrete barrier.

1610.03(3)(c) Placing Barrier Next to Dissimilar-Height Barrier, Walls, Columns, or Other Structures

(This section will refer to the group of “barriers, walls, columns, or other structures” collectively as a “structure”.)

At times, project conditions may require placing barrier next to a structure with a different height (See Photos A & B). This difference in height could cause an errant vehicle to lean over the shorter barrier and strike the exposed edges of the taller structure (See Photo C). A height difference of 2-inches or less is allowable between a barrier placed adjacent to a structure. Provide mitigation for barriers placed adjacent to a structure with a height difference over 2-inches that are in the Design Clear Zone and addressing any exposed edges for:

- Heights up to 6'-5" (77") measured from the roadway surface and extending out to 1'-6" (18") behind the top front edge of standard height concrete barrier (i.e., Type F concrete barrier (32" tall), standard Single Slope Barrier (34" min. height), etc.).
- Heights up to 6'-5" (77") measured from the roadway surface and extending out for the given deflection distance behind the face of rail of beam guardrail (i.e., Type 31 Guardrail, Thrie Beam Guardrail, etc.)
- Heights up to 15'-1" (181") measured from the roadway surface and extending out to 5'-3" (63") behind the top front edge of high-performance concrete barrier (i.e., High Performance Single Slope Barrier (42" min. height), etc.).
- Contact HQ Bridge for locations requiring Test Level 5 barrier (Note: TL-5 barriers are specialty types of barrier not commonly used by WSDOT that may be used in front of bridge piers or other spot locations).

Possible mitigation strategies include, but are not limited to, the following:

- Placing the shorter barrier run in front of the taller structure with the top front edge or face of rail of the shorter barrier meeting or exceeding the offset requirements from the taller structure as described above.
- Providing a height transition (e.g., height transition barrier, sloped wall segment, other) with a top slope of 6:1 or flatter connecting the barrier run to the dissimilar-height structure (See Photo D).



Photo A: Need for Mitigation - Single Slope Barrier Adjacent to Shorter Bridge Barrier



Photo B: Need for Mitigation - Single Slope Barrier Connecting to Tall Wall



Photo C: Box Truck Leaning Over High Performance Barrier During Impact



Photo D: Mitigation Strategy - Type F to Single Slope Transition (Height & Shape)

1610.03(4) Sight Distance

When selecting and placing a barrier system, consider the possible impact the barrier type and height may have on sight distance. In some cases, barriers may restrict the sight distances of road users entering the roadway, such as from road approaches, intersections, and other locations. In these cases, the barrier may need to be adjusted to meet the sight distance requirements at these locations.

1610.03(5) Barrier Deflections

Expect all barriers, except for certain types of rigid barriers (such as concrete bridge rails, barrier integral to retaining walls, or embedded cast-in-place barriers), to deflect when hit by an errant vehicle. The amount of deflection is primarily dependent on the stiffness of the system. However, vehicle speed, angle of impact, and weight of the vehicle also affect the amount of barrier deflection.

For roadside or wide median installations of flexible and semi-rigid roadside barriers (high tension cable barrier and beam guardrail), the deflection distance is designed to prevent the impacting vehicle from striking the object being shielded. For unrestrained rigid systems (unanchored precast concrete barrier), the deflection distance is designed to help prevent the barrier from being knocked over the side of a drop-off or steep fill slope (2H:1V or steeper).

For narrower median installations, design systems so that the anticipated deflection will not enter the lane of opposing traffic. When evaluating new barrier installations, consider whether impacts would require significant traffic closures to accomplish maintenance. Rigid embedded barrier systems are used when no barrier deflection is necessary or desired (areas such as narrow medians, at the edge of bridge decks, or other vertical drop-off areas). Runs of rigid embedded concrete barrier can be precast, cast in place, or extruded with appropriate footings.

In locations where deflection distance is limited, precast concrete barrier can be anchored. Some movement can be expected for rigid anchored barrier systems and repairs may be more expensive (anchoring pins may damage the asphalt or concrete surface that the barrier is placed upon during a vehicle collision).

Use of an anchored precast concrete barrier and other deflecting barrier systems placed on top of a retaining wall at less than the deflection distances provided in [Exhibit 1610-3](#) requires approval from the HQ Design Office. See Section [1610.06](#) for more information on concrete barrier.

[Exhibit 1610-3](#) provides barrier deflection design values when selecting standard runs of longitudinal barrier. This exhibit does not provide deflection values for specialty barrier system placements or installations.

See Section [1610.04\(7\)](#) for:

- long span guardrail system placements [Std. Plan C-20.40](#)
- box culvert guardrail system placements [Std. Plan C-20.41 or C-20.43](#)
- Short Radius Guardrail System (SRGS) placements [Std. Plan C-20.44](#)
- Type 31 guardrail installed on a flare, the ends of Type 31 guardrail runs when terminated with an anchor [Std. Plan C-20.14 or C-20.18](#)

See Section [1610.04\(5\)\(c\)](#) for:

- Bullnose Guardrail Terminal [Std. Plan C-20.55](#)

Refer to related Standard Plans showing specialty barrier system placements or installation placement cases for additional details about deflections and dimensions that are useful in design or contact HQ Design. The deflection values for cable and beam guardrail are minimum distances measured between the face of the barrier to the fixed feature. The deflection values for concrete barrier are minimum distances measured from the back edge of the barrier to the fixed feature, drop-off, or slope break.

Exhibit 1610-3 Longitudinal Barrier Deflection

Barrier Type	System Type	Deflection Distance
High-tension cable barrier	Flexible	6 ft to 10 ft typical [1] (measured from face of barrier to object)
Beam guardrail, Types 1, 1a, 2, and 10	Semi-rigid	3 ft [3] (measured from face of barrier to object)
Beam guardrail, two-sided Types 3, and 4	Semi-rigid	4 ft (measured from nearest face of barrier to object)
Beam guardrail Type 31 (including two-sided and omitted post)	Semi-rigid	5 ft (measured from face of barrier to object)
Permanent precast concrete barrier, unanchored	Rigid Unrestrained	6 ft (measured from back of barrier to object, slope break point, or drop-off) [7]
Permanent precast concrete barrier, unanchored (When placed in front of a 2:1 or flatter fill slope on right hand shoulders and not shielding any fixed objects. Contact HQ Design before using this deflection condition for barrier placed in medians)	Rigid Unrestrained	3 ft (measured from back of barrier to slope break point) [7]
Permanent precast concrete barrier, anchored	Rigid Anchored	2 ft (measured from back of barrier to object, slope break point, or drop-off) [7]
Temporary precast concrete barrier, unanchored [4]	Rigid Unrestrained	3 ft [2] (measured from back of barrier to object, slope break point, or drop-off)
Temporary precast concrete barrier, anchored [4]	Rigid Anchored	1 ft [2] [5] (measured from back of barrier to object, slope break point, or drop-off)
Cast in place or precast concrete barrier, embedded	Rigid Embedded	No deflection [6][7]

Notes:

This exhibit provides deflection values for standard runs of barrier. It does not provide deflection values for specialty barrier system placements or installations such as long span guardrail system placements, box culvert guardrail system placements, Short Radius Guardrail System (SRGS) placement, Bull Nose Terminal, Type 31 barrier installed on a flare, the ends of Type 31 guardrail runs when terminated with an anchor, etc. See [Section 1610.03\(5\)](#) for more information.

[1] See Section [1610.05\(2\)](#)

[2] When used as temporary bridge rail, anchor all barrier when the back of barrier is located within 3 feet of a drop-off.

[3] Place any new objects a minimum of 5 feet from the face of existing beam guardrail type 1.

[4] Steel barrier is also available for temporary applications. See [Chapter 1010](#) for more information.

[5] When anchoring temporary precast concrete barrier on bridges or other drop-offs, see applicable Standard Plans for anchorage details, lateral offsets, and deflection distances.

[6] See Section [1610.06\(1\)\(b\)](#) for Single-Slope barrier design and placement requirements.

[7] See [Exhibit 1239-3](#), [Exhibit 1239-4](#), Section [1610.06\(1\)\(a\)](#), and [Std. Plan C-60.10](#) for shoulder widening and paving behind barrier requirements.

1610.03(6) Minimum/Maximum Barrier System Lengths

At times, the barrier Length of Need (LON) formulas may calculate barrier run lengths that are quite short in order to shield an object or feature. Regardless of the calculated barrier Length of Need, barrier runs require a minimum installed length in order to retain their ability to contain and redirect an impacting vehicle.

In addition, a maximum allowable run length is required for longer runs of high-tension cable barrier. Longer runs of high-tension cable barrier can be more difficult to maintain.

[Exhibit 1610-4](#) gives the required minimum and maximum lengths for standard runs of barriers currently used by WSDOT:

Exhibit 1610-4 Barrier Standard Run Minimum/Maximum Lengths

Barrier Type	Minimum Run Length	Maximum Run Length
High-Tension Cable Barrier	No Minimum	10,000-feet *
Beam Guardrail Type 31	75-feet *	No Maximum
Permanent precast concrete barrier, unanchored	200-feet	No Maximum
Permanent precast concrete barrier, anchored	100-feet	No Maximum
Temporary precast concrete barrier, unanchored	200-feet	No Maximum
Temporary precast concrete barrier, anchored	100-feet	No Maximum
Cast in place concrete barrier, embedded	40-feet	No Maximum
Precast concrete barrier, embedded	80-feet	No Maximum

* Minimum/maximum barrier run lengths includes the standard run, transition(s), terminal(s), and anchor(s) of the High-Tension Cable Barrier and Beam Guardrail systems.

Note: This section does not apply to bridge barrier, moment slab barrier, or other structural type barrier (e.g., barrier attached to walls/foundations, etc.). Contact HQ Bridge for required minimum lengths of these types of barriers.

1610.03(7) Flare Rate

A roadside barrier is considered flared when it is not parallel to the edge of the traveled way.

Flare the ends of longitudinal barriers where site constraints allow (see Section [1610.01](#)). The four functions of a flare are to:

- Maximize the distance between the barrier (and its terminal) and the travelled way.
- Reduce the length of need.
- Redirect an errant vehicle.
- Minimize a driver's reaction to the introduction of an object near the traveled way.

Keeping flare rates as flat as site constraints allow preserves the barrier's redirection performance and minimizes the angle of impact. It has also been shown that an object (or barrier) close to the traveled way might cause a driver to shift laterally, slow down, or both. The flare reduces this reaction by gradually introducing the barrier so the driver does not perceive the barrier as an object to be avoided. The flare rates in [Exhibit 1610-5](#) are intended to satisfy the four functions listed above. Flares that are more gradual may be used. Flare rates are offset parallel to the edge of the traveled way. Transition sections are not flared.

Situations exist where hardware installations may have barrier flare rates different than shown in [Exhibit 1610-5](#). If a *Standard Plan* for a barrier installation shows a different flare rate than is shown in [Exhibit 1610-5](#), use the flare rate shown on the Standard Plan (see [Std. plan C-20.55](#) for bullnose terminals, and [Std. Plan C-22.16](#) for buried terminals).

Exhibit 1610-5 Longitudinal Barrier Flare Rates

Posted Speed (mph)	Rigid & Rigid Anchored System	Unrestrained Rigid System	Semi-rigid
65–70	20:1	18:1	15:1
60	18:1	16:1	14:1
55	16:1	14:1	12:1
50	14:1	12:1	11:1
45	12:1	11:1	10:1
40 or below	11:1	10:1	9:1

1610.03(8) Length of Need

Length of need refers to the total length of longitudinal barrier needed to shield a fixed feature. See [length of need calculation spreadsheet](#).

In many cases, there may be a portion of the traffic barrier installation that is not redirective in capability. For instance:

- if a run of concrete barrier is terminated with an impact attenuator, there will likely be a section of the impact attenuator that is not redirective (see [Chapter 1620](#) for more information).
- If a run of guardrail is terminated with a non-flared terminal or anchor, there will likely be a section of the non-flared terminal or anchor that is not redirective (see [Standard Plans C-22.40](#), [C-22.45](#), or [C-23.70](#)).

Therefore, in most cases, the Length of Need does not equal (i.e., it is shorter than) the actual physical length of the traffic barrier installation required to achieve that length of need.

Length of need is dependent on the location and geometrics of the object, direction(s) of traffic, posted speed, motor vehicle traffic volume, and type and location of traffic barrier.

When designing a barrier to mitigate a fill slope, the length of need begins at the point where the need for slope mitigation is required (see [Section 1600.03\(1\)\(a\)](#)). Once that point is found, determine the amount of barrier needed in advance of this point on relatively straight sections for both adjacent and opposing traffic (see [Exhibit 1610-6](#)). Note: For the LH1 or LH2 distance used in the Length of Need equation, either use the horizontal distance to the toe of the slope or the horizontal distance to the edge of the Design Clear Zone if the slope extends past the Design Clear Zone.

When designing a barrier to mitigate fixed objects and water features, [Exhibit 1610-6](#) shows design parameters for determining the needed length of a barrier for both adjacent and opposing traffic on relatively straight sections of highway. Note: For the LH1 or LH2 distance used in the Length of Need equation, either use the horizontal distance to the back of the fixed object or water feature, or the horizontal distance to the edge of the Design Clear Zone if the fixed object or water feature extends past the Design Clear Zone.

When barrier is to be installed on the outside of a horizontal curve, the length of need can be determined graphically as shown in [Exhibit 1610-8](#). For installations on the inside of a curve, determine the length of need as though it were straight. Also, consider the flare rate, barrier deflection, and barrier end treatment to be used.

When beam guardrail is placed in a median, consider the potential for impact from opposing traffic when conducting a length of need analysis. When guardrail is placed on either side of objects in the median, consider whether the trailing end of each run of guardrail will shield the leading end of the opposing guardrail.

Shield the leading end when it is within the Design Clear Zone of opposing traffic (see [Exhibit 1610-9](#)). This is also a consideration when objects are placed in the outer separations between the main line and collector-distributors.

Before the actual length of need is determined, establish the lateral distance between the proposed barrier installation and the object shielded. Provide a distance that is greater than or equal to the anticipated deflection of the longitudinal barrier. (See [Exhibit 1610-3](#) for barrier deflections.) Place the barrier as far from the edge of the traveled way as possible while maintaining the deflection distance.

If the end of the length of need is within 300 feet of another barrier run (either existing or proposed), it is recommended that the barriers be connected to form a continuous run except where the gap involves a buried terminal and cut slope. In these cases and where practicable, extend barrier runs beyond the length of need to a backslope and provide a buried terminal (see Section [1610.06\(3\)](#) for concrete barrier buried terminal, and Section [1610.04\(5\)](#) and Standard Plan C-22.16 for beam guardrail buried terminal).

Where access is needed behind a barrier (e.g., maintenance access, utility objects, road approaches, etc.) and an alternative approach to providing access is not practicable, provide a gap in the barrier that meets the access need using a configuration where the termination of the downstream run is situated behind the upstream run, or is otherwise outside the Design Clear Zone. Where this overlapping configuration is not practicable, provide a minimum size gap in the guardrail run to meet the access need and evaluate the need for barrier terminals on the upstream and downstream runs.

Exhibit 1610-6 Barrier Length of Need on Tangent Sections

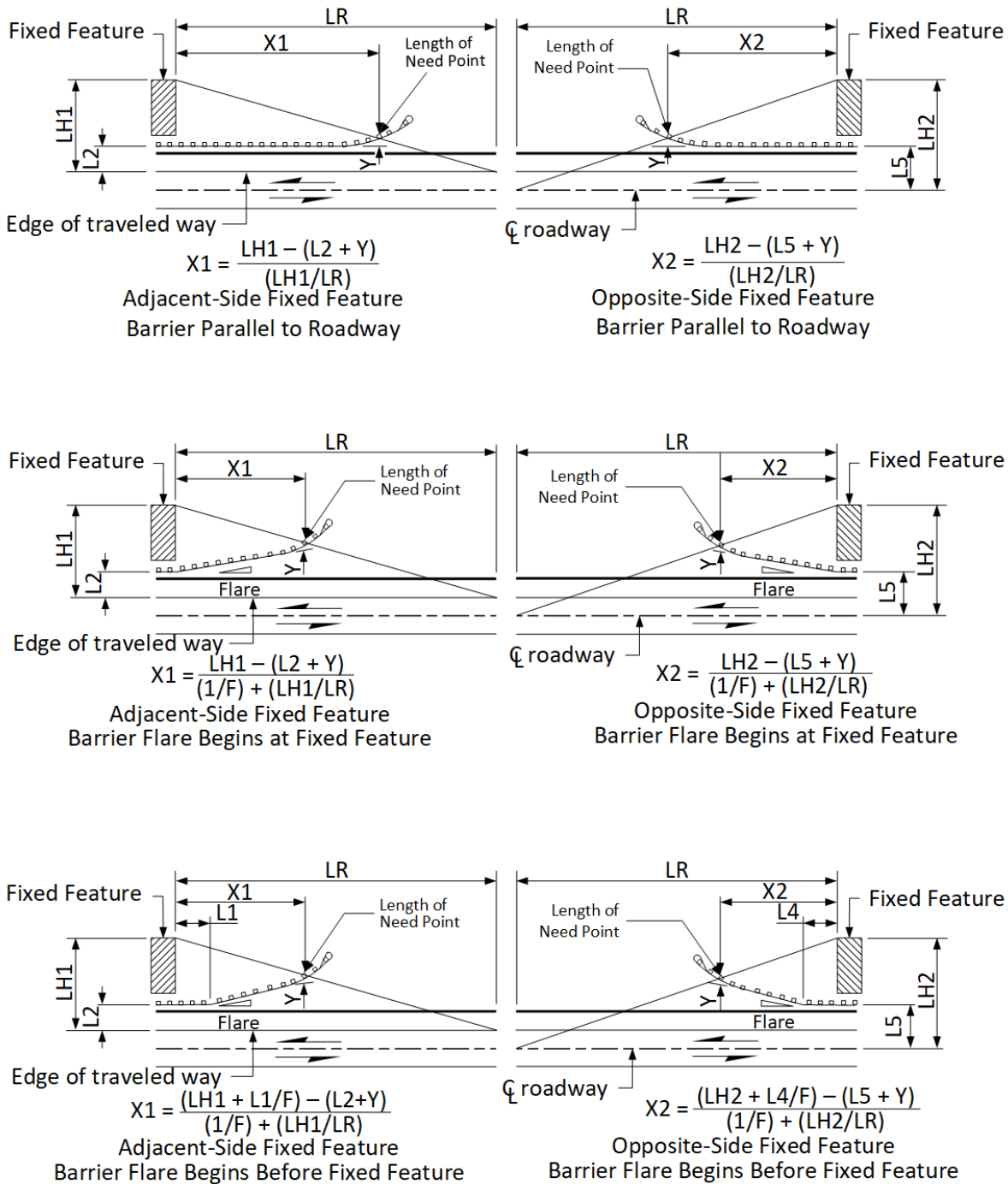

Notes:

1. For supporting length of need equation factors, see [Exhibit 1610-7](#).
2. See [length of need calculation spreadsheet](#).
3. For Length of Need points on non-flared terminals/anchors, see [Standard Plans C-22.40, C-22.45, or C-23.70](#).
4. For Length of Need points on impact attenuators, see [Chapter 1620](#) for more information.

Exhibit 1610-7 Barrier Length of Need

Posted Speed (mph)	Design Parameters						
	ADT				Barrier Type		
	Over 10,000	5,000 to 10,000	1,000 to 4,999	Under 1,000	Rigid & Rigid Anchored Barrier	Rigid Unrestrained Barrier	Semi-rigid Barrier
	LR (ft)	LR (ft)	LR (ft)	LR (ft)	F	F	F
70	360	330	290	250	20	18	15
65	330	290	250	225	20	18	15
60	300	250	210	200	18	16	14
55	265	220	185	175	16	14	12
50	230	190	160	150	14	12	11
45	195	160	135	125	12	11	10
40	160	130	110	100	11	10	9
35	135	110	95	85	11	10	9
30	110	90	80	70	11	10	9
25	110	90	80	70	11	10	9

L1 = Length of barrier parallel to roadway from adjacent-side fixed feature to beginning of barrier flare. This is used if a portion of the barrier cannot be flared (such as a bridge rail and the transition).

L2 = Distance from adjacent edge of traveled way to portion of barrier parallel to roadway.

L4 = Length of barrier parallel to roadway from opposite-side fixed feature to beginning of barrier flare.

L5 = Distance from centerline of roadway to portion of barrier parallel to roadway. Note: If the fixed feature is outside the Design Clear Zone when measured from the centerline, it may only be necessary to provide a crash-tested terminal for the barrier (see Section [1610.04\(7\)\(a\)](#) Beam Guardrail Placement Cases).

LH1 = Distance from outside edge of traveled way to back side of adjacent-side fixed feature.

Note: If a fixed feature extends past the Design Clear Zone, the Design Clear Zone can be used as LH1.

LH2 = Distance from centerline of roadway to back side of opposite-side fixed feature. Note: If a fixed feature extends past the Design Clear Zone, the Design Clear Zone can be used as LH2.

LR = Runout length, measured parallel to roadway.

X1 = Length of need for barrier to shield an adjacent-side fixed feature.

X2 = Length of need for barrier to shield an opposite-side fixed feature.

F = Flare rate value.

Y = Offset distance needed at the beginning of the length of need.

Different end treatments need different offsets:

- For the SRT 350 and FLEAT 350, use Y = 1.8 feet.
- For evaluating existing BCTs, use Y = 1.8 feet.
- For the FLEAT TL-2, use Y = 0.8 feet.
- No offset is needed for the non-flared terminals or impact attenuator systems. Use Y = 0.

Exhibit 1610-8 Barrier Length of Need on Curves

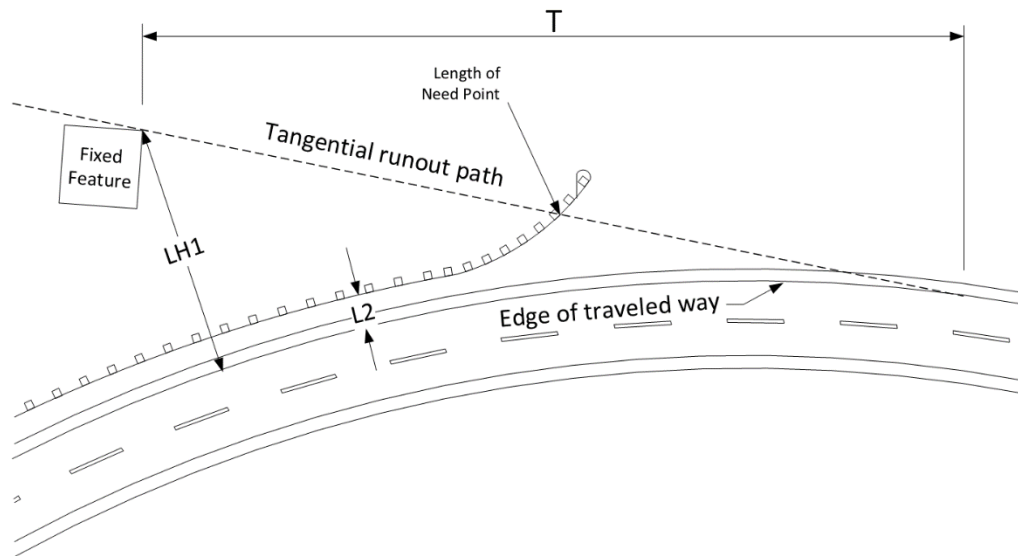

Notes:

- This is a graphical method for determining the length of need for barrier on the outside of a curve.
- On a scale drawing, draw a tangent from the curve to the back of the fixed feature. Compare T to LR from [Exhibit 1610-7](#) and use the shorter value.
- If using LR, follow [Exhibit 1610-6](#) and [Exhibit 1610-7](#).
- If using T, draw the intersecting barrier run to scale and measure the length of need.
- See Section [1610.04\(5\)\(b\)](#) for more information on installing non-flared terminals along horizontal curves.

Exhibit 1610-9 Beam Guardrail Trailing End Placement for Divided Highways

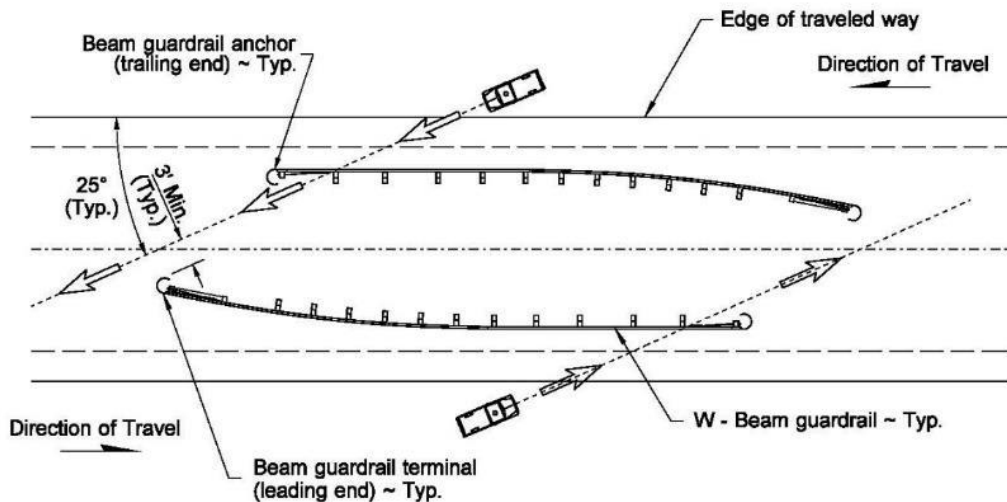
**1610.03(9) Barrier Delineation**

Refer to [Chapter 1030](#) for barrier delineation requirements.

1610.04 Beam Guardrail

Strong post W-beam guardrail and thrie beam guardrail are semi-rigid barriers used predominantly on roadsides. They have limited application as median barrier. A strong-post W-beam (commonly referred to as W-Beam) guardrail system is the most common type of guardrail system used. The design uses wood or steel posts, rail, and blockouts to support the rail away from the post. The system resists a vehicle impact through a combination of the tensile and flexural stiffness of the rail and the bending or shearing resistance of the post.

Installed incorrectly, strong post W-beam guardrail can cause vehicle snagging or spearing. This can be avoided by lapping the rail splices in the direction of traffic (as shown in the [Standard Plans](#)), by using crash-tested end treatments, and by blocking the rail away from the posts.

Beam guardrail systems are shown in the [Standard Plans](#).

1610.04(1) Beam Guardrail Systems

1610.04(1)(a) Type 31 Beam Guardrail

Use Type 31 guardrail for new installations. The Type 31 system uses many of the same components as the old WSDOT Type 1 system. The main differences are that the blockouts extend 12 inches from the posts, the rail height is 31 inches from the ground to the top of the rail, the deflection requirements are 2 feet greater, and the rail elements are spliced between posts.

Type 31 guardrail offers tolerance for future HMA overlays. The system allows a 3-inch tolerance from 31 inches to 28 inches without adjustment of the rail element.

Type 31 guardrail is available double-sided, which can be used in medians.

1610.04(1)(b) (Old) Type 1 Beam Guardrail

Previous WSDOT standard practice was to install W-beam guardrail at a rail height of 27 to 28 inches and is referred to as "Type 1" guardrail. WSDOT has discontinued the use of Type 1 guardrail in new installations. Install new fixed objects or features a minimum of 5 feet behind the face of existing Beam Guardrail Type 1. For more information on (Old) Beam Guardrail Type 1, see: [Roadside safety | WSDOT \(wa.gov\)](#).

Existing runs of serviceable Type 1 guardrail are acceptable to leave in place (see Section [1610.03\(2\)](#) for more information about the serviceability of beam guardrail). If an existing run of Type 1 guardrail requires extending, use the Beam Guardrail Type 31 to Beam Guardrail Type 1 Adaptor shown in the [Standard Plans](#), and complete the guardrail extension using Type 31 guardrail.

1610.04(1)(c) Other Guardrail Types

W-beam guardrail Type 2 and Type 3 have a height of 30 inches and utilize a rubrail. A rubrail is a structural steel channel added below the W-beam rail and is used in these specific designs to reduce vehicle snagging on the post. Existing runs of serviceable Type 2 or Type 3 guardrail are acceptable to leave in place (see Section [1610.03\(2\)](#) for more information about the serviceability of beam guardrail). If the existing run of Type 2 or 3 requires extending contact WSDOT Design Office to identify appropriate extension methods.

Type 4 guardrail is a double-sided version of the Type 1 guardrail system. For new installation, use the Type 31 double-sided w-beam guardrail instead of Type 4 guardrail. Existing runs of serviceable Type 4 guardrail are acceptable to leave in place (see Section [1610.03\(2\)](#) for more information about the serviceability of beam guardrail). If the existing run of Type 4 requires extending contact WSDOT Design Office to identify appropriate extension methods to transition to the Type 31 double-sided system.

Type 10 and Type 11 are three-beam guardrail systems. Existing runs of serviceable Type 10 or 11 guardrail are acceptable to leave in place (see Section [1610.03\(2\)](#) for more information about the serviceability of beam guardrail). If an existing run of Type 10 or Type 11 guardrail requires extending, contact the WSDOT Design Office to discuss options.

Weak post W-beam guardrail (Type 20) and three beam guardrail (Type 21) are flexible barrier systems primarily used in conjunction with a Service Level 1 bridge rail system for bridges with timber decks. These systems use weak steel posts. For information on Type 20 and Type 21 guardrail see: [Roadside safety | WSDOT \(wa.gov\)](#)

1610.04(2) Beam Guardrail Placement

There are a number of considerations regarding guardrail placement. These include:

- During the project development processes, consult with maintenance staff to help identify guardrail runs that may need to be modified.
- When existing Type 1 guardrail is replaced by Type 31 guardrail along existing shoulders with a width greater than 4 feet (5 feet for bicycles), the shoulder width may be reduced by 4 inches to accommodate the 12-inch blockout. A Design Analysis is not required for the reduced shoulder width. If the remaining shoulder width is 4 feet or less, see [Chapter 1030](#) for barrier delineation guidance.
- Keep the slope of the area between the edge of the shoulder and the face of the guardrail 10H:1V or flatter.
- Type 31 or Type 1 beam guardrail can be placed anywhere outside of the shoulder on fill slopes 10:1 or flatter.
- Type 1 beam guardrail can be placed on fill slopes between 6H:1V and 10H:1V at the slope break point of the shoulder or at least 12 feet from the slope breakpoint. This placement case does not apply to Type 31 beam guardrail.
- Do not place Type 31 or Type 1 beam guardrail with standard length posts on a fill slope steeper than 6H:1V. See [Exhibit 1610-10](#) for allowable placement exceptions on fill slopes steeper than 6H:1V using long post beam guardrail.
- Place beam guardrail a minimum of 5-feet away from the slope break point of fill slopes steeper than 1H:1V (measured from face of rail to the slope break point).
- See [Exhibit 730-12](#) for beam guardrail placement on top of retaining walls.
- On the high side of superelevated sections, place beam guardrail at the edge of shoulder prior to the slope breakpoint.
- For W-beam guardrail installed at or near the shoulder, 2 feet of widening behind the barrier is generally provided from the back of the post to the slope breakpoint of a fill slope (see [Exhibit 1610-10](#), Case 2). If the slope is 2H:1V or flatter, this distance can be 2.5 feet measured from the face of the guardrail rather than the back of the post (see [Exhibit 1610-10](#), Case 1).
- On projects where no roadway widening is proposed and site constraints prevent providing the 2-foot shoulder widening behind the barrier, long post installations are available as shown in [Exhibit 1610-10](#), Cases 3, 4, 5, and 6. When installing guardrail where the roadway is to be widened or along new alignments, the use of Cases 5 and 6 requires a Design Analysis.

Exhibit 1610-10 Beam Guardrail Post Installation

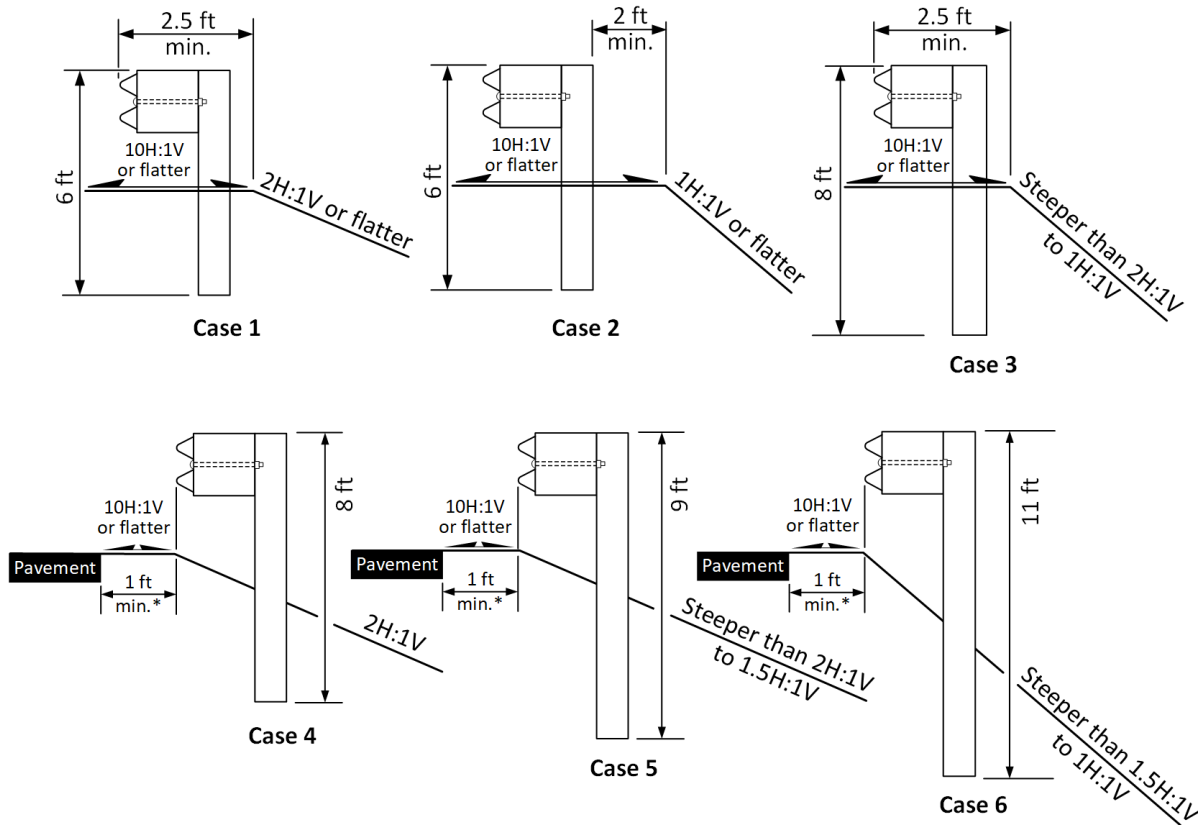

*Provide 1-foot minimum of unpaved shoulder from edge of pavement to slope breakpoint in new construction and shoulder widening to preserve the edge of pavement and side slopes from erosion (See [Exhibit 1239-4](#)).

Notes:

- Use Cases 1 and 3 when 2.5-foot or greater shoulder widening exists or will be constructed from face of guardrail to the slope breakpoint. The use of Case 3 is not allowed on slopes steeper than 1H:1V.
- Use Case 2 when 4.0-foot or greater shoulder widening exists or will be constructed from face of the guardrail to the slope breakpoint.
- Use Cases 4, 5, and 6 when less than a 2.5-foot shoulder widening exists or will be constructed from face of guardrail to the slope breakpoint (see [Section 1610.04\(2\)](#)). The use of Case 4 is not allowed on slopes flatter than 2H:1V. The use of Case 6 is not allowed on slopes steeper than 1H:1V.
- Cases shown do not apply to terminals, transition sections, or anchors. Install terminals, transition sections, and anchors per applicable Design Manual requirements and Standard Plans.
- Cases shown only apply to standard guardrail run installations that are placed parallel to the roadway. Apply Case 2 when installing guardrail on a flare (see [Section 1610.03\(7\)](#)) or on a radius (see [Section 1610.04\(7\)\(a\)](#)).
- See [Exhibit 1239-4](#) for shoulder widening/grading details associated with guardrail.
- See [Section 1610.04\(2\)](#) for beam guardrail placement in front of fill slopes steeper than 1H:1V.
- See [Exhibit 730-12](#) for beam guardrail placement on top of retaining walls.

1610.04(3) W-Beam Barrier Height

See [Chapter 1120](#) when evaluating guardrail system height on Preservation (P1, P2, P3) projects.

For other projects requiring evaluation of guardrail (see Section [1105.02\(1\)](#)), evaluate the guardrail system height as follows:

- For existing Type 1 guardrail with heights falling outside the range from 26.5 inches to 31 inches, adjust or replace the rail to a minimum height of 28 inches up to a maximum height of 30 inches, or replace the run with 31-inch-high Type 31 beam guardrail.
- For existing Type 31 guardrail runs with heights falling outside the range of 28 to 32 inches, adjust or replace the rail to a height of 31 inches, or replace the run with a new run of 31-inch-high Type 31 beam guardrail.

For Type 1 and Type 31 standard run W-beam guardrail, the blockout and rail element may be raised up to 4 inches by field drilling a new hole in the guardrail post. Verify that the condition of the posts and blockouts are suitable for raising in this manner. If not, the post or block will need to be replaced. See the *Standard Plans*.

If Type 1 Alternative W-beam guardrail is present, the blockout and rail element may be raised after each overlay by using the pre-drilled holes in the guardrail posts.

See Section [1610.04\(5\)](#) for information on adjusting the height of guardrail terminals.

1610.04(4) Additional Guidance

Additional guidance related to w-beam guardrail:

- Crossroad and driveway locations cause gaps in the guardrail creating situations requiring special consideration. The preferred solutions are either to eliminate the need for the barrier or realign the crossroad or driveway to accommodate the necessary guardrail run length. Alternatively, an intersection design guardrail system can be installed at the intersection. See Section [1610.04\(7\)\(a\)](#) for more information. At these locations, a barrier flare might be needed to provide sight distance.
- Snowload post and rail washers are not used in new guardrail installations or guardrail terminal installations. Snowload post and rail washers installed on existing guardrail installations may remain in place except when the rail element is removed from post for any reason. If this occurs, remove and discard the snowload post and rail washers before reassembling the guardrail components.
- The use of curb in conjunction with beam guardrail is a special application. When a curb is needed, place the curb as follows:
 - For Type 1 W-beam guardrail, a 3-inch-high curb is preferred, and the front face of the curb is placed flush with the face of rail or placed behind the face of the rail. The 3-inch-high curb can be used at any posted speed. If necessary, a 4-inch-high extruded curb with the front face of the curb placed flush with the face of rail or placed behind the face of the rail can be used at any posted speed. Finally, a 6-inch-high extruded curb with the front face of the curb placed flush with the face of rail or placed behind the face of the rail can be used where the posted speed is 50 mph or below. When replacing extruded curb at locations where the posted speed is above 50 mph, use 3-inch-high or 4-inch-high curb. (See *Standard Plan* F-10.42 for extruded curb designs and *Standard Plan* F-10.40 for extruded curb placement under guardrail.)
 - For Type 31 W-beam guardrail, a 3-inch, 4-inch, or 6-inch curb can be placed at any posted speed with the front face of the curb placed flush with the face of rail or placed behind the face of the rail. Use the shortest height curb feasible. An acceptable option is to install a 3-inch, 4-inch, or 6-inch-high extruded curb with the front face of the curb placed at a maximum 6-inch offset in front of the rail face at any posted speed.

- It is acceptable to place Type 31 W-beam guardrail behind curb and sidewalk when utilizing a proper offset behind the curb and sidewalk. Type 31 W-beam guardrail shall be placed 4- to 12-feet behind the front face of a 3-inch, 4-inch, or 6-inch curb and sidewalk for posted speeds of 45 mph or below. Use the shortest height curb possible. Do not place Type 31 guardrail behind curb and sidewalk in locations with posted speeds greater than 45 mph.
- Guardrail posts should be able to rotate when the rail is impacted. When installing strong post W-beam guardrail posts in a rigid surface such as asphalt or concrete pavement, use leave-outs. Leave-outs are areas around the post that has no rigid material, which allows the post to rotate. Contact the WSDOT Design Office for more information.
- For (Old) Guardrail Types 1, 2, 3, and 4, it is acceptable to use blockouts that extend the rail element from the post for a distance not to exceed 16 inches.
- Where it is not feasible to install a post on a Type 31 system (i.e. utility or drainage conflict), one post may be omitted every 56.25 feet (9th post), except that an omitted post must be a minimum of 75 feet from an anchorage post, a minimum of 35 feet from the beginning of a three beam transition, and a minimum of 35 feet from the point where a terminal system joins the standard run.
 - Do not omit posts in guardrail runs with posts placed less than 2 feet from the slope break point. Guardrail runs with omitted posts must have at least 2 feet of 10:1 or flatter embankment behind them as shown in DM [Exhibit 1610-11](#) Case 2.
 - Do not omit posts where curb is in front of the guardrail.
 - Consult HQ Design for acceptable conditions to omit single posts in guardrail runs with 12' – 6", 18' – 9", or 25' – 0" span systems (see Std. Plan C-20.40) placed within the run.
 - List all the locations of omitted posts in the project plans to ensure that posts are omitted following the conditions described in this section.
- In locations where shallow fill depth prevents the installation of standard-length guardrail posts (i.e., box culverts, drainage), guardrail can be spanned over the location or be attached to the top of the structure (see [Section 1610.04\(7\)\(a\)](#) for more information).

1610.04(5) Terminals and Anchors

A guardrail anchor is required at the end of a run of guardrail to develop tensile strength throughout its length. In addition, when the end of the guardrail is within the Design Clear Zone and subject to head-on impacts, a crash-tested guardrail terminal is required (see the [Standard Plans](#)).

See [Chapter 1120](#) for guidance regarding the evaluation of terminals on Preservation projects (P1, P2, and P3).

For projects that require the evaluation of terminals (see [Section 1105.02\(1\)](#)), evaluate the terminals as follows:

- Replace guardrail terminals that do not have a crash-tested design with MASH compliant crash-tested guardrail terminals. Common features of systems that do not meet current crash-tested designs include:
 - No cable anchor.
 - A cable anchored into concrete in front of the first post.
 - Second post not breakaway (CRT).
 - Design A end section (see Beam Guardrail End Sections plan sheet in the Traffic Barrier (TB) section of the Plan Sheet Library).
 - Design C end sections may be left in place if the terminal is otherwise a crash-tested design —see the [Standard Plan C-7](#) for end section details.

- Buried guardrail terminals that slope down such that the guardrail height is reduced to less than 28 inches (measured in relation to a 10H:1V line extended from the breakpoint at edge of shoulder).
- When the height of a terminal or anchor, as measured from the ground to the top of the rail element, will be affected by the project, adjust the terminal or anchor based upon the following criteria:
 - If the height of the terminal or anchor adjoining Types 1, 2, 3, or 4 guardrail will be reduced by the project to be less than 26.5 inches or increased to greater than 30 inches, adjust the height of the terminal to a minimum of 28 inches and a maximum of 30 inches. A terminal height of 30 inches is desirable to accommodate future overlays.
 - If the height of the terminal or anchor adjoining Type 31 guardrail will be reduced by the project to be less than 28 inches or increased to greater than 32 inches, adjust the height to 31 inches.
 - When adjusting terminals that are equipped with CRT posts, the top-drilled holes in the posts need to remain at the surface of the ground.
 - When adjusting the height of a terminal or anchor, adjust it by raising the posts of the terminal or anchor and tamping the ground around the posts to prevent settlement of the raised posts. Note: do not raise the blockouts or rail of the terminal or anchor by drilling new holes in the terminal posts.

One terminal that was used extensively on Washington's highways was the Breakaway Cable Terminal (BCT). This system used a parabolic flare similar to the Slotted Rail Terminal (SRT) and a Type 1 anchor (Type 1 anchor posts are wood set in a steel tube or a concrete foundation). For guidance regarding BCT's and other terminals on Preservation projects see [Chapter 1120](#). For non-Preservation projects, replace BCTs with a currently approved terminal using the following guidance:

- Verify length of need and adjust the terminal location as required.
- Replace adjacent transition sections that are not compliant with Section [1610.04\(6\)](#).
- Transition from Type 1 to Type 31 using the adaptor (Standard Plan C-25.80) where required.
- Raise or replace the entire run if engineering judgment indicates that it is prudent for that situation.
- Use the grading criteria shown on the terminal standard plans (C-22.40 or C-22.45). When using existing grading, check to see that it complies with the grading criteria shown on the current terminal standard plans.
- Remove curbs from in front of terminals if hydraulically acceptable.

Information regarding (Old) Type 1 beam guardrail terminals can be found at: [Roadside safety | WSDOT \(wa.gov\)](#)

1610.04(5)(a) Buried Terminal for Type 31 Beam Guardrail

A Buried Terminal (BT) is designed to terminate the guardrail by burying the end in a backslope. The BT is the preferred terminal because it eliminates the exposed end of the guardrail.

For new BT installations, use the Buried Terminal Type 2. Previously, another BT option (the Buried Terminal Type 1) was an available choice. For existing installations, it is acceptable to leave this option in service as long as height requirements and other design criteria is met. See Beam Guardrail Type 1 – Buried Terminal Type 2 plan sheet in the Traffic Barrier (TB) section of the WSDOT Plan Sheet Library.

The BT uses a Type 2 anchor to develop the tensile strength in the guardrail. The backslope needed to install a BT is to be 3H:1V or steeper and at least 4 feet in height above the roadway. Note: Do not place a mound of soil or base material over the Type 2 anchor located at the end of the buried terminal system. Install Type 2 anchors into the backslope of a roadway as described in this section.

The entire BT can be used within the length of need for backslopes of 1H:1V or steeper if the barrier remains at full height in relation to the roadway shoulder to the point where the barrier enters the backslope.

For backslopes between 1H:1V and 3H:1V, design the length of need beginning at the point where the W-beam remains at full height in relation to the roadway shoulder—usually beginning at the point where the barrier crosses the ditch line. If the backslope is flatter than 1H:1V, provide a minimum 20-foot-wide by 75-foot-long clear area that is free of fixed features behind the barrier and between the beginning length of need point at the terminal end to the mitigated object to be protected.

Flare the guardrail to the foreslope/backslope intersection using a flare rate that meets the criteria in Section [1610.03\(7\)](#). Provide a 4H:1V or flatter foreslope into the face of the guardrail and maintain the full guardrail height to the foreslope/backslope intersection in relation to a 10H:1V line extending from edge of shoulder breakpoint. (See the [Standard Plans](#) for details.)

Do not install buried terminals behind or coincident with curbs.

1610.04(5)(b) Non-flared Terminals for Type 31 Beam Guardrail

Install a non-flared terminal when a buried terminal cannot be installed as described in Section [1610.04\(5\)\(a\)](#). WSDOT does not use flared terminals on Type 31 guardrail systems. Non-flared terminals typically use w-beam guardrail, proprietary hardware, and an impact head mounted at the leading end. These systems also include an anchor to provide tensile strength for the guardrail. Non-flared terminals absorb energy during head-on impacts by processing the rail through the impact head in varying ways depending on the manufacturer's own proprietary approach. Although these terminal systems are called non-flared, all manufacturers allow for an offset to move the impact head away from traffic.

For non-flared terminal installations, the following apply:

- Select non-flared terminals based on the posted speed as follows:
 - Non-flared terminals restricted to locations 45 mph or below (TL-2, [Standard Plan C-22.45](#));
 - or non-flared terminals that can be installed at any posted speed (TL-3, [Standard Plan C-22.40](#)).
- Where practicable, provide an offset of up to one-foot over the length of the non-flared terminal (TL-2, [Standard Plan C-22.45](#)) or up to two feet over the length of the non-flared terminal (TL-3, [Standard Plan C-22.40](#)) in reference to the roadway alignment. Non-flared terminal offsets can be provided to increase the clearance between the impact head and traffic to reduce the potential of incidental hits.

- It is acceptable to install non-flared terminals following the alignment of flared standard runs of guardrail with flare rates of 25:1 or flatter in reference to the roadway alignment. For standard runs of guardrail with flare rates steeper than 25:1, the non-flared terminal cannot follow the standard run flared alignment and can only be offset up to 1-foot (TL-2, [Standard Plan C-22.45](#)) or 2-feet (TL-3, [Standard Plan C-22.40](#)) in reference to the roadway alignment.
- Include or confirm that embankment widening is provided as part of the non-flared terminal design and installation (see [Standard Plan C-22.40](#) or [C-22.45](#)).
- Where practicable, install non-flared terminals on tangent sections of roadway.
- It is acceptable to extend the length of a guardrail run beyond its required Length of Need distance so that a non-flared terminal can be installed outside the limits of a horizontal curve.
- For non-flared terminals whose manufacturer allows installation on horizontal curves:
 - It is acceptable to install non-flared terminals with up to a full offset on horizontal curves with radii of 750-feet or greater (radius as measured along the shoulder).
 - Contact HQ Design when installing non-flared terminals on horizontal curves with radii between 500-feet and 750-feet (radius as measured along the shoulder).
 - Do not install non-flared terminals on horizontal curves with radii steeper than 500-feet (radius as measured along the shoulder).
- Do not install snowload rail or post washers within the limits of the non-flared terminals.
- Do not install non-flared terminals behind or coincident with curbs.
- Do not place curbs in advance of non-flared terminals within the limits of widened embankment (see [Standard Plans C-22.40](#) or [C-22.45](#) for widened embankment dimensions).
- Refer to [Standard Plans C-22.40](#) or [C-22.45](#) for additional details about non-flared terminal layout and dimensions that are useful in design including:
 - Terminal lengths and pay limits
 - Embankment widening dimensions
 - Location of the Length of Need point on the terminal as it varies by manufacturer

The roadside safety website provides information on availability or acceptance of different terminal systems including approved shop drawings. (See [Roadside safety | WSDOT \(wa.gov\)](#))

1610.04(5)(c) Bull Nose Terminal (New 2024)

Bull nose terminals (see [Standard Plan C-20.55](#)) are used in median or ramp locations to create a beam guardrail envelope around fixed object(s) or feature(s) (such as a sign bridge foundation or steep critical slope between median bridges). The bull nose terminal system consists of slotted thrie-beam rail panels mounted on breakaway posts near the system's nose followed by standard thrie-beam rail panels and posts near the back of the system. The front nose area slotted thrie-beam rail panels have steel cables installed to contain vehicles in the event of rail rupture.

In frontal impacts, the bull nose terminal is designed to collapse and smoothly decelerate an errant vehicle to a complete stop before reaching the fixed object or feature. In side impacts, the bull nose terminal captures and redirects the errant vehicle away from the fixed object or feature.

For new bull nose terminal installations, use the Beam Guardrail Bull Nose Terminal Type 2 ([Standard Plan C-20.55](#)). Previously, the Beam Guardrail Bull Nose Terminal was an available choice. For existing installations, it is acceptable to leave this terminal in service as long as it is in serviceable condition, and the configuration and layout (height, length, flare rate, etc.) of the bullnose terminal follows the original standard (see [Section 1610.03\(2\)](#) for more information).

See the Beam Guardrail Bull Nose Terminal plan sheets in the Traffic Barrier (TB) section of the WSDOT Plan Sheet Library.

The bull nose terminal requires a clear area directly behind the front nose area that is free of fixed objects. The bull nose terminal requires 10H:1V or flatter grading in advance of the system and directly behind the nose.

The bull nose terminal requires 15H:1V or flatter rail tapers back from the nose. Designers need to pay special attention to the bullnose layout at ramps since the taper rates of the bull nose guardrail legs may not be able to follow the mainline and ramp alignments.

Do not install bull nose terminals behind curb or coincident with curbs. Do not place curbs 60-feet in advance of the bull nose terminal.

Refer to [Standard Plan C-20.55](#) for additional details about bull nose terminal layout and dimensions that are useful in design including:

- Terminal length and pay limits
- Terminal layout options
- Terminal grading requirements
- Terminal clear area requirements

Contact region maintenance to discuss potential long-term maintenance issues. The bull nose terminal is a complex system with many specialized parts.

1610.04(5)(d) Terminal Evolution Considerations

Some currently approved terminals have been in service for a number of years. During this time, there have been minor design changes. However, these minor changes have not changed the devices' approval status. Previous designs for these terminals may remain in place.

Note: If questions arise concerning the current approval status of a device, contact the HQ Design Office for clarification when replacement is being considered.

1610.04(5)(e) Anchors

A guardrail anchor is needed at the end of a run of guardrail to develop tensile strength throughout its length.

- Use the Type 11 anchor to develop the tensile strength of the guardrail on the end of Type 31 guardrail runs where a crash-tested terminal is not needed.
- A Type 2 anchor is used with the buried terminal.

For information on anchor types used in runs of (Old) Beam Guardrail Type 1, see: [Roadside safety | WSDOT \(wa.gov\)](#).

1610.04(6) Transitions and Connections

When there is an abrupt change from one barrier type to a more rigid barrier type, a vehicle hitting the more flexible barrier may be caught in the deflected barrier pocket and directed into the more rigid barrier. This is commonly referred to as "pocketing." A transition stiffens the more flexible barrier by decreasing the post spacing, increasing the post size, and using stiffer beam elements to reduce the possibility of pocketing.

When connecting beam guardrail to a more rigid barrier or a structure use the transitions and connections that are shown in [Exhibit 1610-11](#) and [Exhibit 1610-12](#) and detailed in the [Standard Plans](#). Verify the length of need

(see Section [1610.03\(8\)](#)) when designing transitions, particularly transitions between beam guardrail or end terminals to bridge structures.

Type 21 transitions can be used on highways with all posted speeds to connect w-beam guardrail to single slope, safety shape or vertical concrete barriers.

Type 22 and Type 23 transitions are used to connect w-beam guardrail to thrie beam on bridges.

Type 24 transitions can be used on highways with a posted speed of 45 mph or less to connect w-beam guardrail to single slope, safety shape or vertical concrete barriers.

Type 25 transitions are only used in conjunction with the Short Radius Guardrail System (SRGS). Type 25 Transitions can be used on highways with all posted speeds to connect w-beam guardrail to single slope, safety shape or vertical concrete barriers.

When connecting a Type 21 or Type 24 Transition to an existing vertical faced bridge rail with a low parapet, a special connection plate may be required (see [Standard Plan C-24.15](#)). Coordinate with the WSDOT Bridge and Structures Office (BSO). The transition pay item includes the connection.

Transition sections are not flared (see Section [1610.03\(7\)](#) and C-series transition [Standard Plans](#)). Install a transition parallel to the adjacent roadway and in-line with the concrete barrier or structure that it is attaching to. Install transition rails that are straight (see C-series transition [Standard Plans](#)).

Install transitions on 10:1 or flatter slopes with the 10:1 or flatter slope extending a minimum of 2 feet behind the guardrail transition post similar to what is shown in DM [Exhibit 1610-10](#) Placement Case 2.

For information regarding transitions used with (Old) Type 1 guardrail see: [Roadside safety | WSDOT \(wa.gov\)](#)

Exhibit 1610-11 Guardrail Connections

Condition	Connection
Unrestrained precast concrete barrier	A
Rigid, rigid anchored, untapered safety shape bridge rails or concrete barrier [1]	B
Bridge rails with curbs 9 inches or less in width	B
Bridge rails with curbs between 9 and 18 inches wide	C
Rigid, or rigid anchored: vertical walls, single slope bridge rail, single-slope concrete barrier, tapered safety shape bridge rail, and tapered safety shape barrier [1]	D
All bridge rail and concrete barrier types located on trailing ends of one-way roadways	F

Note:

- [1] New single slope and safety shape bridge rails are designed with the toe of the barrier tapered so that it does not project past the face of the approach guardrail.

Exhibit 1610-12 Transitions and Connections

Connecting Type 31 W-Beam Guardrail to:		Transition Type*	Connection	
Bridge Rail ^[1]	New Installation		21, 24 ^[3] , 25	
	Existing Concrete	Concrete Parapet > (Greater Than) 20 in.	21, 24 ^[3] , 25	Exhibit 1610-11 ^[2]
		Concrete Parapet < (Less Than) 20 in.	21, 24 ^[3] , 25	Exhibit 1610-11 ^[2]
	Thrie Beam at Face of Curb	Approach End	23	n/a
		Trailing End (two-way traffic only)	23	n/a
	Thrie Beam at Bridge Rail (curb exposed)	Approach End	22	n/a
Trailing End (two-way traffic only)		22	n/a	
Concrete Barrier	Rigid & Rigid Anchored	21, 24 ^[3] , 25	Exhibit 1610-11	
	Unrestrained	21, 24 ^[3] , 25	A	
Connecting Thrie Beam Guardrail to:		Transition Type*	Connection	
Bridge Rail or Concrete Barrier	See the thrie beam transition in the Plan Sheet Library		Exhibit 1610-11	

*Consult Section C of the [Standard Plans](#) for details on transition types.

Notes:

- [1] For Service Level 1 bridge rail, see the Plan Sheet Library for Type 1 Beam Guardrail Placement Cases, Placement Case 14.
- [2] When connecting a Type 21, Type 24, or Type 25 Transition to an existing vertical faced bridge rail with a low parapet, a special connection plate may be required (see Standard Plan C-24.15).
- [3] Transition Type 21 and 25 are acceptable for use on highways with all posted speeds. Transition Type 24 is acceptable for use on highways with posted speeds 45 mph or below.
- [4] Use an F Connection at new installations of bridge rail or concrete barrier when located on the trailing ends of one-way roadways.

1610.04(7) Guardrail Placement Cases

The [Standard Plans](#) and [Plan Sheet Library](#) contain placement cases that show beam guardrail elements needed for typical situations. For new installations, use the appropriate Type 31 placement option (except as noted below). Information regarding placement cases for (Old) Type 1 beam guardrail can be found at [Roadside safety | WSDOT \(wa.gov\)](#).

1610.04(7)(a) Beam Guardrail Placement Cases

- Case 1-31 is used where there is one-way traffic. It uses a crash-tested terminal on the approach end and a Type 11 anchor on the trailing end.
- Case 2-31 is used where there is two-way traffic. A crash-tested terminal is used on both ends.
- Case 3-31 is used at railroad signal supports on one-way or two-way roadways. A terminal is used on the approach end, but usually cannot be used on the trailing end because of its proximity to the railroad tracks. If there is a history of crossover collisions, consider additional protection such as an impact attenuator.

- Case 4-31 is used where guardrail on the approach to a bridge is to be shifted laterally to connect with the bridge rail. A terminal is used on the approach end and a transition is needed at the bridge end. Curves (bends) are shown in the guardrail to shift it to the bridge rail. However, the length of the curves are not critical. The criterion is to provide smooth curves that are not more abrupt than the allowable flare rate (see [Exhibit 1610-5](#)).
- Case 5-31 is a typical bridge approach where a terminal and a transition are needed.
- Case 10 (A-31, B-31, and C-31) is used at roadside fixed features (such as bridge piers) when 5 or more feet are available from the face of the guardrail to the feature. The approach end is the same for one-way or two-way traffic. Case 10A-31 is used with two-way traffic; therefore, a terminal is needed on the trailing end. Case 10B-31 is used for one-way traffic when there is no need to extend guardrail past the fixed feature and a Type 11 anchor is used to end the guardrail. Case 10C-31 is used for one-way traffic when the guardrail will extend for a distance past the fixed object.
- The Beam Guardrail Type 31 Placement 12'-6", 18'-9", or 25'-0" Span design is used when it is necessary to omit one, two, or three posts. This application is typically used when guardrail is installed over a shallow buried obstruction, such as drainage structures. This design may be used in other situations where there are no above ground objects located behind the guardrail and within the lateral deflection distance. Three CRT posts are provided on each end of the omitted post(s). Type 31 guardrail (including terminals and anchors) must extend at least 62.5 feet (10 posts) upstream and downstream from the ends of the outer CRT posts (furthest from obstruction) in order for the guardrail system to function as designed during a vehicle crash. Also, this guardrail design has specific grading requirements, see applicable standard plan. Note: This guardrail design may require fall protection. See Section [Chapter 1060](#) for worker fall protection requirements. See Section [1510.15\(3\)](#) for pedestrian fall protection requirements. When a fall protection system is located within the deflection zone of the barrier system, contact HQ Design for options.
- The Box Culvert Guardrail Steel Post ~ Type 31 ([Standard Plan C-20.41](#)) and Box Culvert Bolt-Thru Anchor Guardrail Steel Post ~ Type 31 ([Standard Plan C-20.43](#)) systems can both be used when the top of a shallow fill buried culvert does not allow standard guardrail posts to be installed to their full depth.
 - The Box Culvert Guardrail Steel Post ~ Type 31 uses a resin bonded anchor to attach the guardrail post to the lid. When impacted, this type of post attachment may damage the culvert lid by spalling the concrete. However, repairs to the system can be accessed from the top of the culvert.
 - The Box Culvert Bolt-Thru Anchor Guardrail Steel Post ~ Type 31 uses a steel bolt passing through the post base and culvert lid to attach the guardrail post to the lid. When impacted, this attachment type is less likely to damage the culvert lid. The bolt will typically shear before causing damage/spalling to the culvert lid in an impact. However, repair of bolt-thru posts requires maintenance access underneath the culvert which may be problematic in deep or fast running water.
 - When a barrier design requires the guardrail posts to be attached to the top of a structure, either: (1) Notify the structure designer from HQ Bridge about the guardrail post attachment requirement, or (2) Follow the design requirements for a structure with attached guardrail posts provided in Chapter 8 of the Bridge Design Manual. Contact Region Maintenance to discuss any potential long term maintenance concerns with these barrier systems.

- Guardrail Placement at intersections – The Short Radius Guardrail System (SRGS) ~ Type 31 Intersection Design (Standard Plan C-20.44) is currently available for use where bridge ends or similar conditions exist near a roadway intersection or road approach/driveway. The SRGS is used at crossroads or road approaches/driveways where a barrier is needed and where the length of need cannot be achieved using standard components such as standard longitudinal barrier runs, transitions, and terminals. For SRGS installations, the following apply:
 - The SRGS system is designed to be used when the intersection angle of the mainline roadway and the intersecting roadway or road approach/driveway is 90-degrees.
 - The SRGS uses radii of 8-, 16-, or 24-feet. Ensure the selected SRGS system radius matches the intersecting roadway or road approach/driveway return radius as close as possible.
 - The SRGS extends approximately 50-feet (or longer depending on the system radius used) down the intersecting roadway or road approach/driveway. Ensure all associated right of way acquisitions are completed as early in the design process as possible.
 - Refer to Standard Plan C-20.44 for additional details about the SRGS layout and dimensions that are useful in design such as grading requirements, required clear area behind the system, different system radius options, and connection to bridge ends or other similar conditions, etc.

1610.05 High-Tension Cable Barrier

Cable barrier is a flexible barrier system that can be used on a roadside or as a median barrier. Early cable barrier designs centered around low-tension cable systems. With research and crash analysis of these systems, the designs evolved into high-tension cable systems. These high-tension cable systems are primarily used in medians and are preferred for many installations due in part to high benefit-to-cost ratios.

There are a number of manufacturers of high-tension cable barrier systems. These systems have been designed using either three or four-cables fixed to metal posts placed at a fixed spacing. Each cable system has specially designed anchors placed at both ends of the barrier run to provide the proper tensioning in the cables. Currently, both three and four-cable high-tension cable barrier systems are installed along WSDOT state routes. Use four-cable high-tension cable barrier systems for all new installations.

1610.05(1) High-Tension Cable Barrier Placement

High-tension cable barrier can be placed in a median or along the roadside.

Note: For non-typical installations, such as double runs of cable barrier or median ditch cross sections that differ significantly from those shown, contact the HQ Design Office for guidance.

1610.05(1)(a) Median Applications

For typical cable barrier installations in a median, the following apply (see [Exhibit 1610-13](#)):

- Install the cable barrier as far from the edge of traveled way as site constraints allow. Consider a minimum placement distance of 8 feet from the edge of traveled way to allow vehicles to use this area for refuge.
- Install cable barrier on slopes 6H:1V or flatter.
- There are approved high-tension cable barrier systems that can be placed on slopes as steep as 4H:1V. The use of these systems requires special placement considerations, contact the HQ Design Office for guidance.

- Provide an obstruction free zone within the cable barrier system’s lateral deflection distance (see Section [1610.05\(2\)](#)).
- On tangent sections of a roadway where no ditch is present, consider installing the cable barrier in the middle of the median. See [Exhibit 1610-13](#).
- Along horizontal curves, consider installing the cable barrier along the inside of the curve. Reduce the post spacing per manufacturer’s recommendations.
- In medians with ditches, install the cable barrier as follows (See [Exhibit 1610-13](#)):
 - The preferred location is to install the cable barrier at an 8-foot or greater offset from the ditch centerline.
 - Alternatively, the cable barrier can be installed at the centerline of the ditch out to a 1-foot offset either side of the ditch centerline. While permissible, this is not the preferred area to install cable barrier due to the potential of post scour, possible interference with drainage structures, and maintenance concerns.
 - Do not install cable barrier in the area between 1-foot to 8-foot offset from the ditch centerline to avoid “under-riding” of vehicles crossing the ditch.
- In some situations, it may be advantageous to terminate a run of cable barrier on one side of the median (to provide maintenance access to a feature, for example) and then begin an adjacent cable barrier run on the opposite side of the median. In this application, it is important to provide adequate cable barrier overlap distance between the two runs. For placement guidance, see [Exhibit 1610-15](#).
- Narrow medians provide little space for maintenance crews to repair or reposition the barrier. Wherever site conditions permit, provide at least 14 feet of clearance from the adjacent lane edge to the face of the cable barrier.

Exhibit 1610-13 Median Cable Barrier Placement

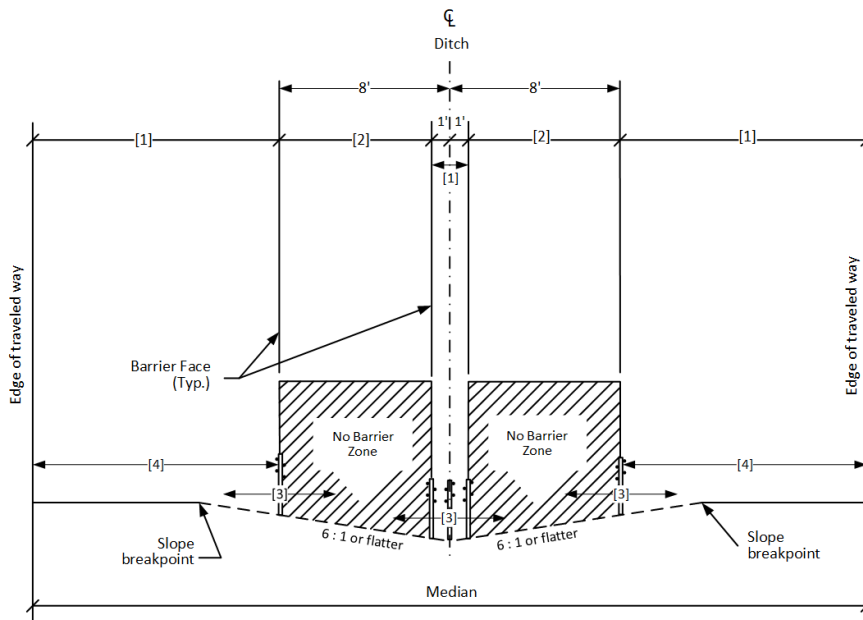

Median Cable Barrier Placement (Ditch Section with 6 : 1 or Flatter Slopes)

Note: This exhibit shows 5 cable barrier runs illustrating the 3 allowable location zones for placing cable barrier in a median ditch. Typical median cable barrier placements are comprised of a single cable barrier run in one of the 3 allowable location zones.

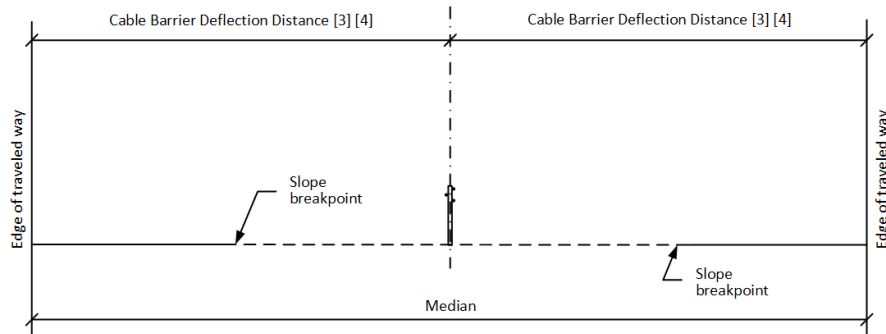

Median Cable Barrier Placement (No Ditch)

Notes:

- [1] Cable barrier may be installed at an 8-foot or greater offset from the ditch centerline (preferred placement), or it may be installed in the center of the ditch out to a 1-foot offset from the ditch centerline (left or right). See Section 1610.05(1)(a) for additional cable barrier median placement information.
- [2] Avoid installing cable barrier in the area between 1-foot to 8-foot offset from the ditch centerline (left or right). See Section 1610.05(1)(a) for additional cable barrier median placement information.
- [3] Provide an obstruction free zone within the cable barrier’s lateral deflection distance from both sides of the barrier (errant vehicles can impact cable barrier from both sides). See Section 1610.05(2) for additional deflection information.
- [4] Provide sufficient lateral cable barrier deflection distance to prevent a vehicle’s encroachment into the opposite lane of travel. See Section 1610.05(2) for additional deflection information.

1610.05(1)(b) Roadside Applications

For typical non-median roadside applications, the following apply:

- Install the cable barrier as far from the edge of traveled way as site constraints allow.
- Consider a minimum placement distance of 8 feet from the edge of traveled way to allow vehicles to use this area for refuge.
- Install cable barrier on slopes 6H:1V or flatter.
- There are approved high-tension cable barrier systems that can be placed on slopes as steep as 4H:1V. The use of these systems requires special placement considerations, contact the HQ Design Office for guidance.
- Along horizontal curves, consider installing along the inside of the curve. Reduce post spacing per manufacturer's recommendations.
- Provide an obstruction free zone within the cable barrier system's lateral deflection distance, see Section [1610.05\(2\)](#).

Exhibit 1610-14 Roadside Cable Barrier Placement

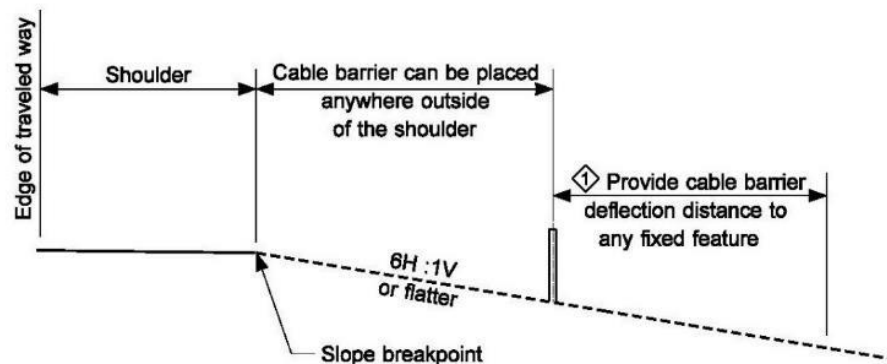

Notes:



Provide an obstruction free zone within the cable barrier's lateral deflection distance, see Section [1610.05\(2\)](#).

1610.05(2) High-Tension Cable Barrier Lateral Deflection Distances

Depending on the high-tension cable barrier system, lateral deflection distances for each barrier system vary based upon the length of the barrier run, the spacing of the end anchors, and post spacing. Provide an obstruction free zone within the system's lateral deflection distance for the following situations:

1. In the direction of travel (located in the median or along roadside), locate the cable barrier system so that there are no fixed objects within the limits of the cable barrier lateral deflection distance.
2. For opposing traffic (where present), locate the cable barrier to provide lateral deflection distance to prevent a vehicle's encroachment into the opposite lane of travel.
3. Low-tension cable barrier systems require 12 feet of lateral deflection. Use high-tension cable barrier systems in new cable barrier installations.
4. High-tension barrier systems have lateral deflection distances between 6 to 10 feet. Specify the maximum allowable lateral deflection distance in the contract documents in order for the contractor to select a cable barrier manufacturer that meets the lateral deflection requirements.

Note: There are new high-tension cable barrier systems under development that may change selection and placement criteria. For example, newer systems may allow placement on steeper slopes or have reduced deflection distances. Contact the HQ Design Office for guidance.

1610.05(3) High-Tension Cable Barrier Termination

Manufacturers of high-tension four-cable barrier systems provide designed anchors for the ends of cable barrier runs. Whenever practicable, locate high-tension cable barrier terminals in areas where they are least likely to be hit by errant vehicles (e.g., located outside clear zone, located behind another barrier system).

Often, high-tension cable barrier systems will overlap/interface with a stiffer barrier system (typically beam guardrail but can be concrete barrier). When terminating a cable barrier run to begin a beam guardrail run, there are essentially four choices for the overlap/interface of the two barrier systems (contact HQ Design when terminating a cable barrier run to begin a concrete barrier run). The four choices are:

Connect Cable Barrier to Beam Guardrail: This placement connects the cable barrier directly onto the beam guardrail runs (such as cable barrier connected to beam guardrail transitions coming off bridge rails) or to a different cable barrier anchorage system.

When connecting cable barrier onto beam guardrail, the guardrail must continue at least 75 feet downstream from the point where the cable barrier attaches to the beam guardrail, or the beam guardrail needs to be connected to a stiffer system (i.e., bridge rail, concrete barrier) to reduce the chance of beam guardrail posts pulling out of the ground from the tension in the cable barrier system. When terminating cable barrier in this manner; review field conditions, check local maintenance personnel needs, and specify the required connection option in the contract documents.

When cable barrier is connected directly to a more rigid barrier, a transition section is typically needed. Contact the HQ Design Office for further details.

Install Cable Barrier Behind Beam Guardrail: This placement terminates the cable barrier behind the beam guardrail system. Ensure the lateral distance between the two barrier systems exceeds the deflection distance of the beam guardrail system placed in front of the cable barrier system. This will reduce the chances of having the two barrier systems interfering with each other during a vehicle impact, or having an errant vehicle rebound off the cable barrier into the back of the beam guardrail during a vehicle impact. [Exhibit 1610-16](#) shows an example of terminating cable barrier behind a beam guardrail system.

Install Cable Barrier in Front of Beam Guardrail: This placement terminates the cable barrier in front of the beam guardrail system. Ensure that the standard run of cable barrier extends to, or past, the Length of Need post of the beam guardrail terminal and provide a minimum lateral distance of 4-feet between the two barrier systems. This will reduce the chances of having the two barrier systems interfere with each other during a vehicle impact. [Exhibit 1610-16](#) shows an example of terminating cable barrier in front of a beam guardrail system.

Terminate Cable Barrier in Advance of Beam Guardrail: This placement terminates the cable barrier in advance of the beam guardrail system. This placement leaves a gap in guardrail coverage and can be a maintenance concern if both terminals are hit by an errant vehicle. However, this placement can be used when side slope grades become an issue (i.e., slope is too steep to place cable barrier or beam guardrail, slope widening requires large amounts of fill to accommodate barrier systems). [Exhibit 1610-16](#) shows an example of terminating cable barrier in advance of a beam guardrail system.

Exhibit 1610-15 Cable Barrier Placement: Overlap on Divided Highways

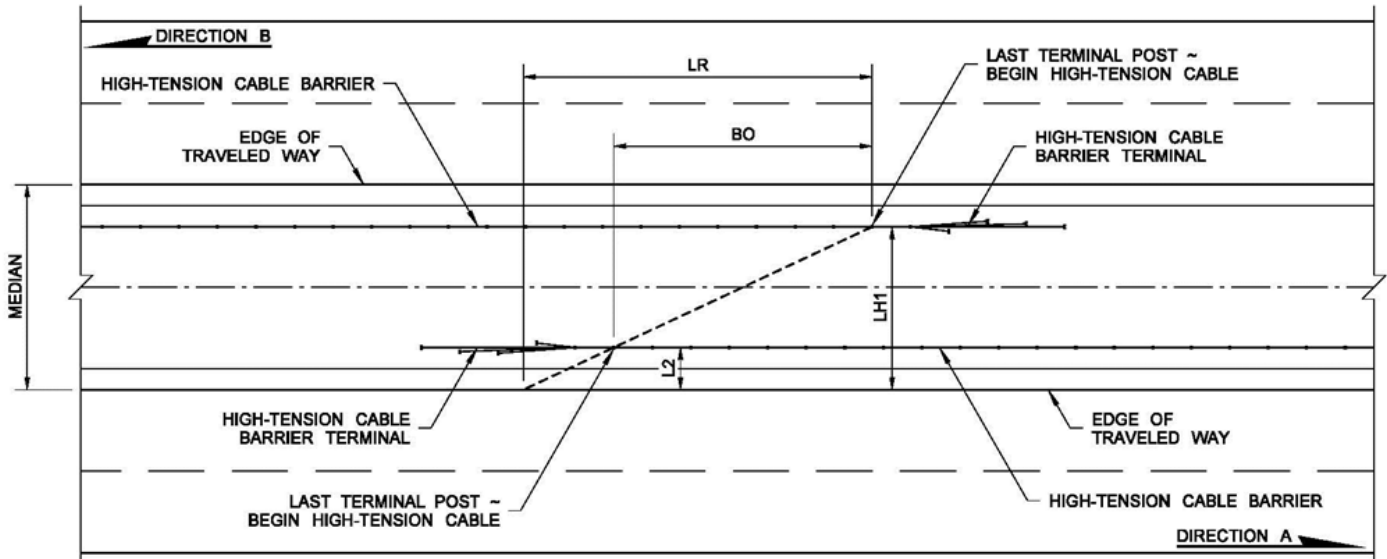

Cable Barrier Median Overlap

$$BO = (LH1 - L2)/(LH1/LR) \text{ (Direction A shown)}$$

Notes:

- Calculate barrier overlap (BO) from both directions of travel. Use the greatest value of BO obtained.
- For supporting length of need equation factors, see [Exhibit 1610-7](#).

Exhibit 1610-16 Cable Barrier Placement: Cable Barrier Termination/Overlap with Beam Guardrail

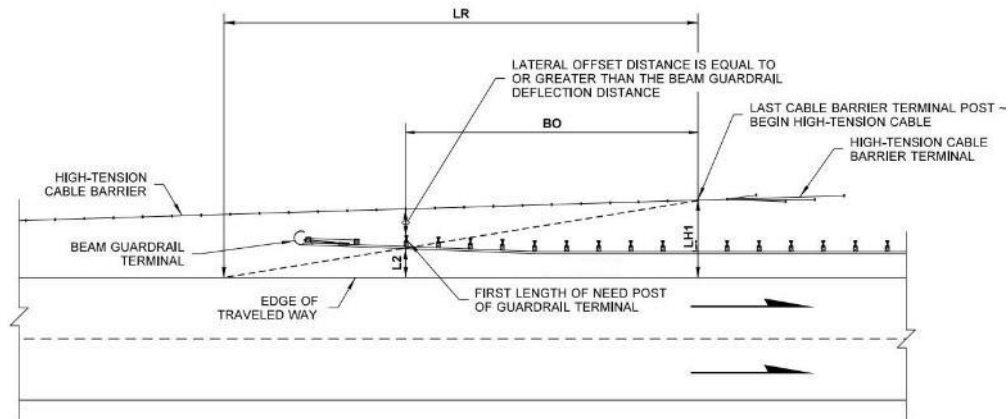

$$BO = (LH1 - L2) / (LH1 / LR)$$

Cable Barrier Termination: Install Behind Beam Guardrail

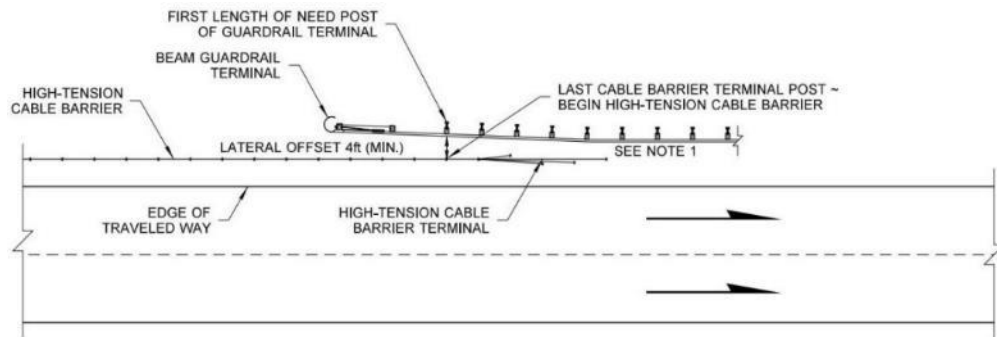

Cable Barrier Termination: Install in Front of Beam Guardrail

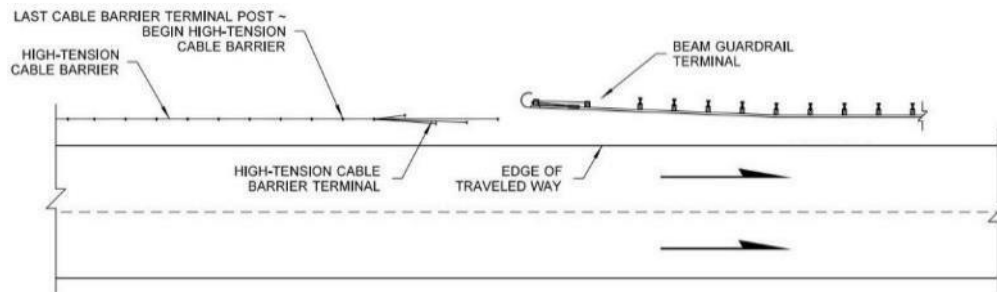

Cable Barrier Termination: Terminate In Advance of Beam Guardrail

Notes:

These barrier placements can be placed in both roadside and medians.

- [1] The beam guardrail may need to be extended and flared in advance of a cable barrier terminal to maintain adequate barrier overlap, lateral offset distance between barrier systems, and shoulder width.
- [2] Typical applications may be at either bridge transitions or where high-tension cable and beam guardrail systems end or begin.
- [3] For supporting length of need equation factors, see [Exhibit 1610-7](#).

1610.05(4) High-Tension Cable Barrier Curb Placement

Avoid the placement of curb in conjunction with high-tension cable barrier systems. Currently, there are no known acceptable cable barrier systems that have been successfully crash tested with this feature present.

1610.06 Concrete Barrier

Concrete barriers are identified as either rigid, rigid anchored, or unrestrained rigid systems. They are commonly used in medians and as shoulder barriers. These systems are stiffer than beam guardrail or cable barrier and impacts with these barriers tend to be more severe. Consider the following when installing concrete barriers:

- For slopes 10H:1V or flatter, concrete barrier can be used anywhere outside of the shoulder.
- Do not use concrete barrier at locations where the foreslope into the face of the barrier is steeper than 10H:1V.
- Light standards mounted on top of precast concrete median barrier must not have breakaway features. (See the concrete barrier light standard section in the [Standard Plans](#).)
- When considering concrete barrier use in areas where drainage and environmental issues (such as stormwater, wildlife, or endangered species) might be adversely impacted, contact the HQ Hydraulics Office and/or the appropriate environmental offices for guidance. Also, refer to Section [1610.02](#).

1610.06(1) Concrete Barrier Shapes

Concrete barriers use a single-slope or safety shape (New Jersey or F-Shape) to redirect vehicles while minimizing vehicle vaulting, rolling, and snagging. A comparison of these barrier shapes is shown in [Exhibit 1610-17](#).

The single-slope barrier face is the recommended option for embedded rigid concrete barrier applications.

Exhibit 1610-17 Concrete Barrier Shapes

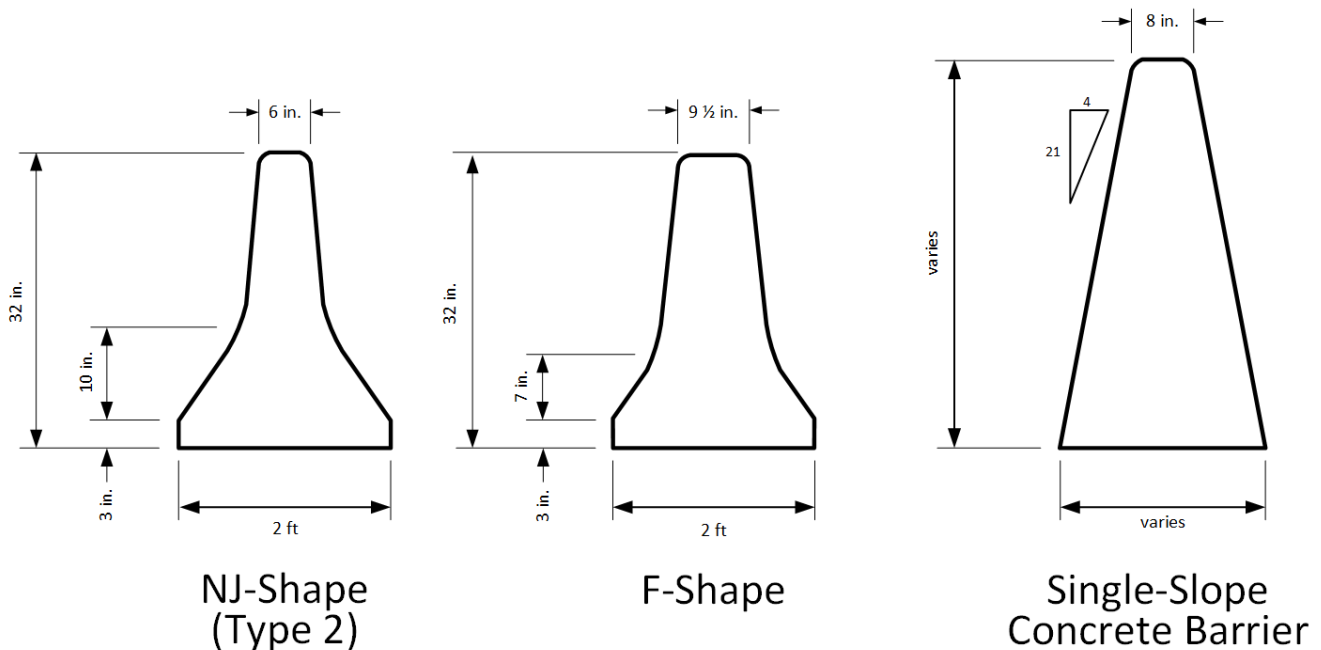

The New Jersey shape and F-shape barriers are commonly referred to as “safety shapes.” The New Jersey shape and F-shape have an initial overall height of 32 inches.

As part of the implementation of MASH-compliant hardware, WSDOT has transitioned from using New Jersey shape barrier (Type 2 barrier) for precast concrete barrier to using F-shape concrete barrier (Type F barrier) instead. F-Shape (Type F) barrier is used in permanent or temporary installations. New Jersey shape (Type 2) barrier is only allowed to be used in temporary installations.

Existing runs of serviceable Type 2 barrier permanently installed are allowed to remain in place (see Section [1610.03\(2\)](#) for more information about the serviceability of concrete barrier). Use Type F when replacing existing Type 2 concrete barrier. If an existing run of Type 2 barrier requires extending, use Standard Plan C-60.30 Concrete Barrier Transition Type F to (32”) Type 2 (Precast), and complete the barrier extension using Type F barrier. When removing and resetting Type 2 barrier, contact HQ Design for more details.

1610.06(1)(a) Safety Shape Barrier

Concrete Barrier Type F (see the [Standard Plans](#)) is a freestanding precast barrier that has the F-shape on both sides. The F-Shape barrier is used in permanent or temporary installations. It can be used for both median and shoulder installations. Unanchored units are connected with steel pins through metal loops. For permanent unanchored Type F barrier installations, this barrier is placed on a 10:1 or flatter paved surface with 3-feet minimum of 10:1 or flatter paved surface provided beyond the back of the barrier for deflection. For temporary unanchored Type F barrier installations, this barrier is placed on a 10:1 or flatter paved or compacted unpaved surface with a minimum of 3-feet of the 10:1 or flatter respective surface provided beyond the barrier for deflection. Do not anchor Type F barrier on a compacted unpaved surface. See [Exhibit 1610-3](#) for deflection requirements.

Concrete Barrier Type 2 (see the [Standard Plans](#)) is a freestanding precast barrier that has the New Jersey shape on both sides. The Type 2 barrier is only used in temporary installations. It can be used for both median and shoulder installations. Unanchored units are connected with steel pins through wire rope loops. For temporary unanchored Type 2 barrier installations, this barrier can be placed on a 10:1 or flatter paved surface or compacted unpaved surface with a minimum of 3-feet of the 10:1 or flatter respective surface provided beyond the barrier for deflection. Do not anchor Type 2 barrier on a compacted unpaved surface. See [Exhibit 1610-3](#) for deflection requirements.

The cost of precast safety shape barrier is significantly less than the cost of the cast-in-place barriers. Therefore, consider the length of the barrier run and the deflection needs to determine whether transitioning to precast barrier is desirable. If precast safety shape barrier is used for the majority of a project, use the single slope barrier for small sections that need cast-in-place barrier (such as for a light standard section). See standard plans for precast concrete barrier transitions between different shapes of concrete barrier.

Type F narrow base is a precast, single-faced F-Shape barrier. These units are not freestanding and are to be placed against a rigid structure (or anchored to the pavement in temporary installations). If Type F narrow base barriers are used back-to-back, fill any gap between them to prevent tipping.

Type F barrier can be anchored where a more rigid barrier is needed. The barrier can be anchored in permanent or temporary installations on asphalt pavement, concrete pavement, or bridge decks (Anchoring methods and the required distances of 10:1 or flatter pavement beyond the back of barrier are shown in the [Standard Plans](#)). Consult with the WSDOT BSO when anchoring permanent precast concrete barrier to a rigid (Portland cement concrete) pavement or bridge deck. Type 2 barrier can be anchored where a more rigid barrier is needed.

The barrier can be anchored in temporary installations using Type 1 and Type 2 anchors for rigid concrete pavement, and Type 3 anchors for asphalt pavement (Anchoring methods and the required distances of 10:1 or flatter pavement beyond the back of barrier are shown in the [Standard Plans](#)). Consult with the WSDOT BSO when anchoring precast concrete barrier to a bridge deck.

Precast barrier used on the approach to bridge rail is to be connected to the bridge rail by installing loops or a loop bar embedded into the bridge rail with epoxy resin and as detailed in the [Standard Plans](#).

Place unrestrained (unanchored) precast concrete barrier on slopes of 5% (20H:1V) or flatter where possible. The maximum slope for placement of concrete barrier is 10% (10H:1V).

1610.06(1)(b) Single-Slope Barrier

Single-slope barrier is an embedded concrete barrier system with a constant 10.8° sloped face (or 21:4 slope). The single-slope barrier is used in permanent installations. Single-slope barrier is available in various heights as shown in the [Standard Plans](#). Single-slope concrete barrier can be cast-in-place or precast. Single-slope barrier is considered a rigid system provided that:

- precast barrier is embedded a minimum of 3-inches in the roadway wearing surface (asphalt or concrete) on both sides;
- precast barrier is embedded a minimum of 10-inches in compacted base material (e.g., CSBC, select borrow, gravel borrow, native soil, etc.) on both sides;
- precast barrier is embedded a minimum of 10-inches when embedded in roadway wearing surface (asphalt or concrete) on one side and compacted base material (e.g., CSBC, select borrow, gravel borrow, native soil, etc.) on the other side; and,
- cast-in-place barrier is embedded a minimum of 3-inches in the roadway wearing surface (asphalt or concrete) or compacted base material (e.g., CSBC, select borrow, gravel borrow, native soil, etc.) on both sides.

Single-slope barrier can only be used: (1) in median applications, (2) in shoulder applications (placed at the edge of roadway meeting fill or cut slope requirements or placed offset from the roadway in front of a fill or cut slope), or (3) on top of an MSE wall. All single-slope barrier, other than median applications, requires 2-foot minimum vertical depth of roadway wearing surface and/or base material (e.g. HMA, CSBC, select borrow, gravel borrow, native soil, etc.) measured from lowest grade next to barrier faces.

When placed in front of a fill slope, provide a minimum distance of 2-feet of widening with a 20H:1V or flatter slope from the back of barrier to the slope break point (see [Exhibit 1610-18](#)).

When placed on top of an MSE wall, provide a minimum distance of 5-feet of widening with a 20:1 or flatter slope from the back of barrier to the back of the wall facing (see [Exhibit 730-12](#)). Contact HQ Bridge when placing a barrier on an MSE wall to ensure proper wall/parapet design.

For new installations in asphalt, concrete, or compacted base material; the minimum height of the single-slope barrier above the roadway is 2 feet 10 inches which allows a 2-inch tolerance for future overlays. The minimum total height of the barrier section is 3-feet-6 inches (including embedment). The single-slope barrier can be installed with grade separation between roadways as follows:

- For cast-in-place barrier with a minimum 3-inch embedment, or pre-cast barrier installed in asphalt or concrete with a minimum 3-inch embedment; a grade separation of up to 4-inches is allowed when using a 3-foot-6-inch tall barrier section, a grade separation of up to 7-inches is allowed when using a 4-foot tall barrier section, and a grade separation of up to 10-inches is allowed when using a 4-foot-6-inch tall barrier section as shown in the [Standard Plans](#).

- For pre-cast barrier installed in compacted base material with a minimum 10-inch embedment; a grade separation of up to 4-inches is allowed when using a 4-foot-tall barrier section, and a grade separation of up to 10-inches is allowed when using a 4-foot-6 inch tall barrier section as shown in the Standard Plans.
- The barrier is to have a depth of embedment equal to or greater than the grade separation as shown in the Standard Plans. Contact the WSDOT BSO for grade separations greater than 10-inches.

Exhibit 1610-18 Single-Slope Barrier Placement – In Front of Fill Slope (New 2024)

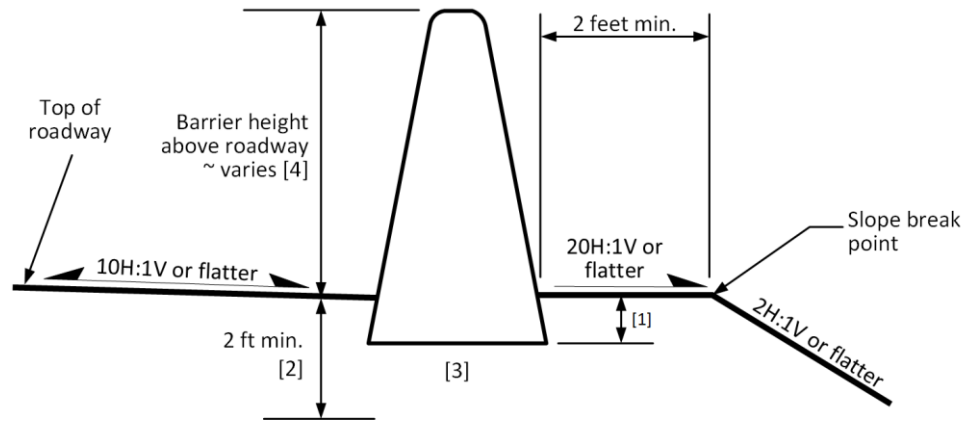

Note: See [Exhibit 1239-4](#) for shoulder widening/grading details associated with concrete barrier.

- [1] See Section [1610.06\(1\)\(b\)](#) for single-slope barrier minimum embedment depth requirements.
- [2] Minimum 2-feet depth of roadway wearing surface and/or base material placed underneath barrier (measured from lowest grade next to barrier faces).
- [3] See Section [1610.06\(1\)\(b\)](#) for single slope barrier grade separation requirements (if used).
- [4] See Section [1610.06\(1\)\(b\)](#) and Section [1610.06\(1\)\(c\)](#) for single-slope barrier height requirements.

1610.06(1)(c) High-Performance Concrete Barrier

High-Performance Concrete Barrier (HP Barrier) is a rigid barrier with a minimum height of 3-foot-6-inch above the roadway surface. This barrier is designed to function more effectively during heavy-vehicle crashes. This taller barrier may also offer the added benefits of reducing headlight glare and reducing noise in surrounding environments. WSDOT HP Barrier utilizes the single-slope shape. (See the [Standard Plans](#) for barrier details.)

Use HP Barrier in freeway medians of 22 feet or less. Also, use HP Barrier on Interstate or freeway routes where crash history suggests a need or where roadway geometrics increase the possibility of larger trucks hitting the barrier at a high angle (for example, on-ramps for freeway-to-freeway connections with sharp curvature in the alignment).

Consider the use of HP Barrier at other locations such as highways with narrow medians, near highly sensitive environmental areas, near densely populated areas, over or near mass transit facilities, or on vertically divided highways.

1610.06(1)(d) Low-Profile Barrier

Low-profile barrier designs are available for median applications where the posted speed is 45 mph or below. These barriers are normally used in urban areas. They are typically 18 to 20 inches high and offer sight distance benefits. For barrier designs, terminals, and further details, contact the HQ Design Office.

1610.06(1)(e) Scupper Barrier (New 2024)

Scupper barrier designs are available for both Type F ([Standard Plan C-60.15](#)) and Single-Slope ([Standard Plan C-70.15](#)) concrete barriers. Scupper barriers are designed with openings located at the base of the concrete barrier that allow water to pass through. This may present long-term maintenance issues due to scuppers becoming clogged with debris. See the Hydraulics Manual for drainage design guidance on scupper barrier. Use of scupper barrier in both permanent and temporary applications requires Region Hydraulic Engineer approval. It is recommended to contact region hydraulics early in the design process to determine suitability. See Sections [1610.06\(1\)\(a\)](#) or [1610.06\(1\)\(c\)](#) for design and placement guidance associated with single slope or Type F barriers.

1610.06(1)(f) Concrete Barrier Transitions

At times, runs of concrete barrier will require a shape and/or stiffness transition to another type of concrete barrier/bridge rail. The following list provides a brief description of the most common types of concrete barrier transitions:

Bridge Transitions: When single-slope or F-Shape faced bridge barrier is used on bridges or structures and precast barrier is selected for use on the approaches to the bridge or structure; a transition section is needed to provide gradual stiffening from the less rigid precast barrier system to the more rigid bridge rail/bridge barrier system. In addition, a transition is needed to ensure that no vertical edges of barrier are exposed to oncoming traffic due to the difference in shapes and height between the two different barrier systems. Note: See Standard Plans for concrete barrier bridge transitions. See the [Bridge Design Manual](#) for details on bridge rails/bridge barrier.

Roadside and Median Shape Transitions: Use a transition section when it is necessary to change the shape of the barrier within a single run (i.e., Type F to Single Slope, Type 2 to Type F) of barrier. Transition designs will differ when used on roadside/wide median applications (barrier subject to vehicle impacts on one side only), or narrow median applications (barrier subject to vehicle impacts on both sides). Note: See [Standard Plans](#) for concrete barrier transitions between different shapes of concrete barrier.

Stiffness Transitions: Use an anchoring transition section when changing the stiffness of the barrier system within a single run of barrier but not the barrier shape (i.e., Type F anchored to Type F unanchored). This type of transition requires a change in anchoring pin configuration when moving from an unanchored barrier system to an anchored barrier system. There is no other change to the barrier other than the anchoring pin configuration. Note: See [Standard Plans](#) for barrier stiffness transitions.

For aesthetic reasons, avoid changes in the shape of the barrier face within a project or corridor whenever possible.

1610.06(2) Concrete Barrier Height

Pavement overlays are allowed to be placed in front of concrete barriers per the following allowable minimum height guidance for each type of barrier:

- Allow no less than 32-inches from the new pavement surface to the top of standard height (not high performance) single-slope barrier.
- Allow no less than 36-inches from the new pavement surface to the top of high performance single-slope barrier.

- Overlays are not allowed in front of safety shape barriers. Safety shape barriers must be adjusted to maintain their 32-inch height, or they must be replaced when an overlay is being placed in locations with these types of barrier.

Note: When placing overlays in front of single slope concrete barriers, ensure that the overlay does not cause the barrier grade separation height to exceed the depth of barrier embedment (see Section [1610.06\(1\)\(b\)](#) and Standard Plan C-70.10 or C-80.10 for more information).

1610.06(3) Concrete Barrier Terminals

Whenever possible, bury the blunt end of a concrete barrier run into the backslope of the roadway. If the end of a concrete barrier run cannot be buried in a backslope or terminated as described below, terminate the barrier using a guardrail terminal and transition or an impact attenuator (see [Chapter 1620](#)).

To bury the blunt end of the barrier into a backslope, the following conditions must be met:

- The backslope is 3H:1V or steeper
- The backslope extends minimum of 4 feet in height above the edge of shoulder
- Flare the concrete barrier into the backslope using a flare rate that meets the criteria in Section [1610.03\(7\)](#)
- Provide a 10H:1V or flatter foreslope into the face of the barrier and maintain the full barrier height until the barrier intersects with the backslope. This might create the need to fill ditches and install culverts in front of the barrier face.

Note: Do not place a mound of soil or base material over the blunt end of a concrete barrier run. Install blunt ends of concrete barrier runs requiring mitigation into the backslope of a roadway, terminate with a guardrail transition and terminal, or terminate with an impact attenuator as described in this section.

The 7-foot-long Type F barrier terminal (precast) and the 10- to 12-foot single-slope barrier terminal (precast or cast-in-place) may be used in the following conditions:

- Outside the Design Clear Zone.
- On the trailing end of the barrier when it is outside the Design Clear Zone for opposing traffic.
- On the trailing end of one-way traffic.
- Where the posted speed is 25 mph or below.

See the [Standard Plans](#) for barrier terminal details.

1610.06(4) Concrete Barrier Placement in Front of Bridge Piers

Existing barrier in front of bridge piers may remain in place in preservation (P1, P2, P3) projects. For all other projects, contact the HQ Bridge Traffic Barrier Specialist when an existing or proposed bridge pier is in the Design Clear Zone, regardless of whether a barrier currently exists.

1610.07 Bridge Traffic Barriers

Bridge traffic barriers redirect errant vehicles and help to keep them from going over the side of the structure. See the [Bridge Design Manual](#) for information regarding bridge barrier on new bridges and replacement bridge barrier on existing bridges.

When considering work on a bridge traffic barrier consult the WSDOT Bridge and Structures Office (BSO).

The standard bridge traffic barrier is a single slope traffic barrier, 3 foot 6 inch in height for Test Level 4 (TL-4) and 3 foot 9 inch in height for Test Level 5 (TL-5). See *Bridge Design Manual* section 10.2.1 for selection of the appropriate test level for bridges and structures.

For corridor continuity, a 2 foot 10 inch tall single slope; a 3 foot 9 inch tall F-shape, 3 foot 6 inch tall F-shape; or 2 foot 8 inch tall F-Shape traffic barrier may be used. Barriers with reveal heights less than 3 foot 6 inch may be used with a pedestrian railing attached to the top for a total height of 3 foot 6 inches. This also meets requirements for worker fall protection.

Approach barriers, transitions, and connections are usually needed on all four corners of bridges carrying two-way traffic and on both corners of the approach end for one-way traffic. See Section 1610.04(6) for guidance on beam guardrail transitions. See standard plans for concrete barrier bridge transitions.

Bridge railing attaches to the top of the bridge barrier. When bridge barrier is included in a project, the bridge rails, including crossroad bridge rail, are to be addressed. Consult the WSDOT BSO regarding bridge rail selection and for design of the connection to an existing bridge.

Consider the following:

- Use an approved, NCHRP 350 or MASH crash-tested bridge traffic barrier on new bridges or bridges to be widened. The *Bridge Design Manual* provides examples of typical bridge rails. The BSO's minimum crash test level for all state and interstate bridges is a TL-4.
- An existing bridge rail on a roadway with a posted speed of 30 mph or below may remain in place if it is not located on a bridge over a National Highway System (NHS) highway. When Type 7 bridge rail is present on a bridge over an NHS highway with a posted speed of 30 mph or below, it may remain in place regardless of the type of metal rail installed. Other bridge rails are to be evaluated for strength and geometrics. (See Section 1610.07(1) for guidance on retrofit techniques.)
- The Type 7 bridge rail is common. Type 7 bridge rails have a curb, a vertical-face parapet, and an aluminum top rail. The curb width and the type of aluminum top rail are factors in determining the adequacy of the Type 7 bridge rail, as shown in [Exhibit 1610-19](#). Consult the WSDOT BSO for assistance in evaluating other bridge rails.
- When considering an overlay on a bridge, consult the WSDOT BSO to verify the overlay depth can be placed on the bridge deck based on the type of traffic barrier. There may be instances where the height of the bridge barrier will not allow for the planned overlay depth without removal of existing pavement.

Exhibit 1610-19 Type 7 Bridge Rail Upgrade Criteria

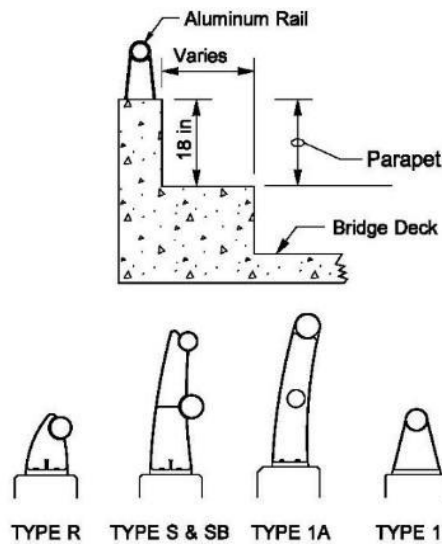

Aluminum Rail Type	Curb Width	
	9 Inches or Less	Greater Than 9 Inches*
Type R, S, or SB	Bridge rail adequate	Bridge rail adequate
Type 1B or 1A	Bridge rail adequate	Upgrade bridge rail
Other	Consult the WSDOT BSO	

*When the curb width is greater than 9 inches, the aluminum rail must be able to withstand a 5-kip load.

1610.07(1) Bridge Barrier Retrofit

If the bridge barrier system does not meet the criteria for strength and geometrics, modifications to improve its redirection characteristics and its strength may be needed. Consult the WSDOT BSO to determine which retrofit method described below can be completed.

1610.07(1)(a) Concrete Safety Shape

Consult the WSDOT BSO to determine whether the existing bridge deck and other superstructure elements are of sufficient strength to accommodate this bridge barrier system and provide design details for the retrofit. Retrofitting with a new concrete bridge barrier is costly and requires authorization from Program Management when no widening is proposed.

1610.07(1)(b) Thrie Beam Retrofit

Retrofitting the bridge barrier with thrie beam is an economical way to improve the strength and redirection performance of a bridge barrier. The thrie beam can be mounted to steel posts or the existing bridge barrier, depending on the structural adequacy of the bridge deck, the existing bridge barrier type, the width of curb (if any), and the curb-to-curb roadway width carried across the structure. [Exhibit 1610-20](#) shows typical retrofit criteria.

Note that Bridges designated as historical landmarks may not be candidates for thrie beam retrofitting. Contact the Environmental Services Office regarding bridge historical landmark status.

Consider the Service Level 1 (SL-1) system on bridges with wooden decks and for bridges with concrete decks that do not have the needed strength to accommodate the thrie beam system. Contact the WSDOT BSO for information needed for the design of the SL-1 system.

If a thrie beam retrofit results in reduction in sidewalk width ensure ADA compliance is addressed, see [Chapter 1510](#).

Exhibit 1610-20 Thrie Beam Rail Retrofit Criteria

Curb Width	Bridge Width	Concrete Bridge Deck		Wood Bridge Deck or Low-Strength Concrete Deck
		Concrete Bridge Rail (existing)	Steel or Wood Post Bridge Rail (existing)	
<18 inches		Thrie beam mounted to existing bridge rail [2] and blocked out to the face of curb. Height = 32 inches.	Thrie beam mounted to steel posts [2] at the face of curb. Height = 32 inches	<ul style="list-style-type: none"> • Service Level 1 Bridge Rail. [2] • Height = 32 inches. • Curb or wheel guard needs to be removed.
>18 inches	> 28 ft (curb to curb)	Thrie beam mounted to steel posts[2] at the face of curb. [1] Height = 32 inches.		
>18 inches	< 28 ft (curb to curb)	Thrie beam mounted to existing bridge rail.[2] Height = 35 inches.	Thrie beam mounted to steel posts [2] in line with existing rail. Height = 35 inches.	

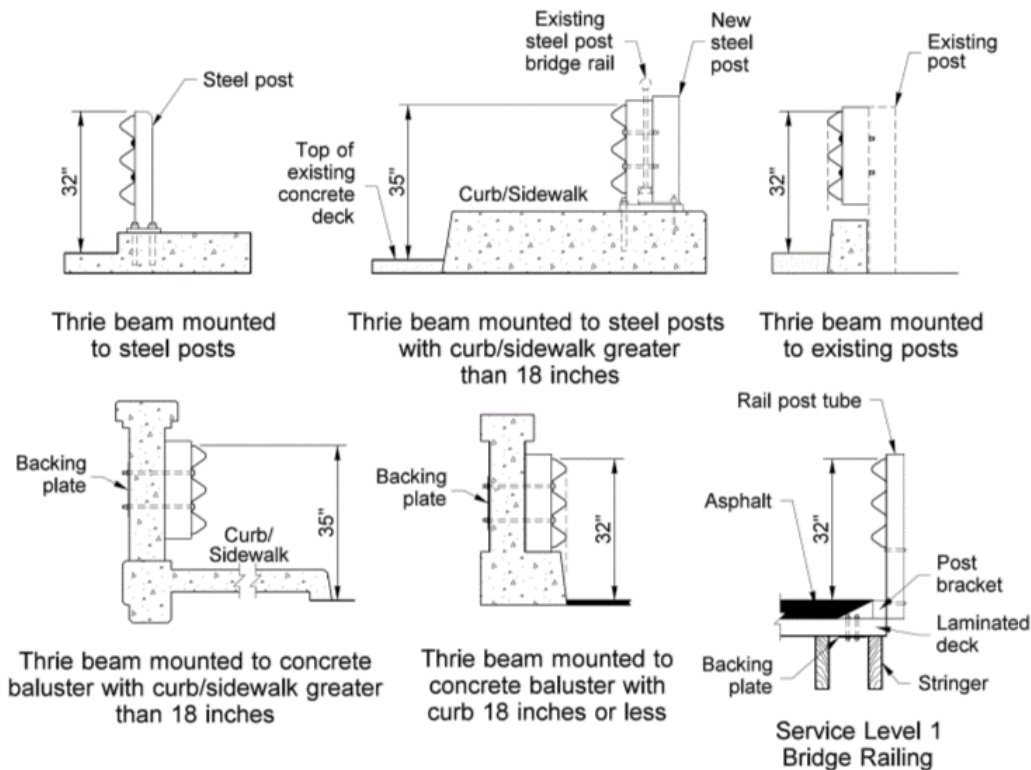

Notes:

- [1] To maximize available curb/sidewalk width for pedestrian use, thrie beam may be mounted to the bridge rail at a height of 35 inches.
- [2] Contact the WSDOT BSO for design details on bridge rail retrofit projects.

1610.08 Other Barriers

1610.08(1) Redirectional Landform

Redirectional landforms, also referred to as earth berms, were formerly installed to help mitigate crashes with fixed objects located in depressed medians and at roadsides. They were constructed of materials that provided support for a traversing vehicle. With slopes in the range of 2H:1V to 3H:1V, they were intended to redirect errant vehicles. The use of redirectional landforms has been discontinued. Where redirectional landforms currently exist as mitigation for a fixed object, provide alternative means of mitigating the fixed object, such as removing, relocating, changing the fixed object to a crash-tested breakaway system, or shielding with barrier.

1610.08(2) Aesthetic Barrier Treatment

An aesthetic barrier may be desired on a project, or it may be required by a memorandum of understanding, a Scenic Byway designation, an easement or corridor management plan, or as a result of stakeholder engagement. Contact the region or HQ Landscape Architect Office to confirm this requirement, and to verify any specific conditions with respect to the barrier's appearance in the applicable plan or corridor document. Reactive coloring agents and powder coating are approved treatment options for w-beam guardrail and may be applicable to other barrier types. Check with the manufacturer and/or the product documentation when specifying aesthetic treatment for proprietary devices, such as guardrail terminals.

One alternative to the use of aesthetic treatments are barriers designed to be aesthetic, such as steel-backed timber guardrail and stone guard walls.

These alternative barriers will likely necessitate a partnering effort because of their higher costs, although grants may be available for this purpose if the need is identified early in the project definition phase.

1610.08(3) Steel-Backed Timber Guardrail

Steel-backed timber guardrails consist of a timber rail with a steel plate attached to the back to increase its tensile strength. There are several variations of this system that have passed crash tests. The nonproprietary systems use a beam with a rectangular cross section that is supported by either wood or steel posts.

A proprietary (patented) system, called the Ironwood Guardrail, is also available. This system uses a beam with a round cross section and is supported by steel posts with a wood covering to give the appearance of an all-wood system from the roadway. The incorporation of the Ironwood Guardrail will need to be documented. Consult with the Assistant State Design Engineer to determine what justification (proprietary or a public interest finding) will be required.

The most desirable method of terminating the steel-backed timber guardrail is to bury the end in a backslope, as described in Section 1610.04(5). When this type of terminal is not possible, use of the barrier is limited to highways with a posted speed of 45 mph or below. On these lower-speed highways, the barriers can be flared away from the traveled way as described in Section 1610.03(7) and terminated in a berm outside the Design Clear Zone.

For details on these systems, contact the HQ Design Office.

1610.08(4) Stone Guardwalls

Stone guardwalls function like rigid concrete barriers but have the appearance of natural stone. These walls can be constructed of stone masonry over a reinforced concrete core wall or of simulated stone concrete. These types of barriers are designed to have a limited textured projection of the stones to help aid in the redirection characteristics of the barrier. The most desirable method of terminating this barrier is to bury the end in a backslope, as described in Section 1610.06(3). When this type of terminal is not possible, use of the barrier is limited to highways with a posted speed of 45 mph or below. On these lower-speed highways, the barrier can be flared away from the traveled way and terminated in a berm outside the Design Clear Zone.

For details on these systems, contact the HQ Design Office.

1610.08(5) Dragnet

The Dragnet Vehicle Arresting Barrier consists of chain link or fiber net that is attached to energy absorbing units. When a vehicle hits the system, the Dragnet brings the vehicle to a controlled stop with limited damage. Possible uses for this device include the following:

- Reversible lane entrances and exits
- Railroad crossings
- Truck escape ramps (instead of arrester beds—see Chapter 1270)
- T-intersections
- Work zones
- Swing span bridges

Coordinate with the HQ Design Office for design details.

1610.09 References

1610.09(1) Design Guidance

WSDOT Roadside Safety site: <https://wsdot.wa.gov/engineering-standards/design-topics/roadside-safety>

Bridge Design Manual LRFD, M 23-50, WSDOT

Roadside Design Guide, AASHTO, 2011 with Errata (July 2015)

Standard Plans for Road, Bridge, and Municipal Construction (Standard Plans), M 21-01, WSDOT

Traffic Manual, M 51-02, WSDOT

1610.09(2) Supporting Information

Manual for Assessing Safety Hardware (MASH), AASHTO, 2016

Manual for Assessing Safety Hardware (MASH), AASHTO, 2009

NCHRP 350, TRB, 1993