

Chapter 10

Signs, Barriers, Approach Slabs, and Utilities

Contents

10.1	Sign and Luminaire Supports	10-1
10.1.1	Loads	10-1
10.1.1.A	General	10-1
10.1.1.B	Dead Loads	10-1
10.1.1.C	Live Load	10-1
10.1.1.D	Wind Loads	10-1
10.1.1.E	Fatigue Design	10-2
10.1.1.F	Ice and Snow Loads	10-2
10.1.1.G	Group Load Combinations	10-2
10.1.1.H	Impact Loads	10-3
10.1.2	Bridge Mounted Signs	10-3
10.1.2.A	Vertical Clearance	10-3
10.1.2.B	Geometrics	10-4
10.1.2.C	Aesthetics	10-5
10.1.2.D	Sign Placement	10-5
10.1.2.E	Installation	10-6
10.1.2.F	Installing/Replacing New Sign on Existing Bracket Supports	10-7
10.1.2.G	Detailing	10-7
10.1.3	Monotube Sign Structures Mounted on Bridges	10-7
10.1.3.A	Design Loads	10-7
10.1.3.B	Vertical Clearance	10-7
10.1.3.C	Geometrics	10-8
10.1.4	Monotube Sign Structures	10-8
10.1.4.A	Sign Bridge Conventional Design	10-8
10.1.4.B	Cantilever Conventional Design	10-8
10.1.4.C	Balanced Cantilever Conventional Design	10-10
10.1.4.D	VMS Installation	10-10
10.1.4.E	Monotube Sheet Guidelines	10-11
10.1.4.F	Monotube Quantities	10-11
10.1.5	Foundations	10-12
10.1.5.A	Monotube Sign Structure Foundation Types	10-12
10.1.5.B	Luminaire, Signal Standard, and Camera Pole Foundation Types	10-12
10.1.5.C	Foundation Design	10-12
10.1.5.C.1	Monotube Sign Structures Foundation Type 1 Design	10-13
10.1.5.C.2	Monotube Sign Structures Foundation Type 2 and 3	10-13
10.1.5.C.3	Monotube Sign Structures Non-Conventional Design Foundations	10-13
10.1.5.C.4	Signal Foundation Design	10-13
10.1.5.D	Foundation Quantities	10-14

10.2	Bridge Traffic Barriers	10-15
10.2.1	General Guidelines	10-15
10.2.2	Bridge Railing Test Levels	10-17
10.2.3	Available WSDOT Designs	10-17
10.2.3.A	Service Level 1 (SL-1) Weak Post Guardrail (TL-2)	10-17
10.2.3.B	Texas T-411 Aesthetic Concrete Baluster (TL-2)	10-18
10.2.3.C	Traffic Barrier – 32" F-Shape (TL-3)	10-18
10.2.3.D	Traffic Barrier – 34" Single Slope (TL-3)	10-19
10.2.3.E	Pedestrian Barrier (TL-3)	10-19
10.2.3.F	Oregon 3-Tube Curb Mounted Traffic Barrier (TL-4)	10-20
10.2.3.G	Traffic Barrier – 42" and 45" F-Shape (TL-4 and TL-5)	10-21
10.2.3.H	Traffic Barrier – 42" and 45" Single Slope (TL-4 and TL-5)	10-21
10.2.4	Design Criteria	10-22
10.2.4.A	Design Values	10-22
10.2.4.B	Geometry	10-23
10.2.4.C	Standard Detail Sheet Modifications	10-23
10.2.4.D	Miscellaneous Design Information	10-24
10.3	At Grade Concrete Barriers	10-26
10.3.1	Differential Grade Concrete Barriers	10-26
10.3.1.A	Differential Grade Concrete Barriers	10-26
10.3.2	Moment Slab Traffic Barrier	10-28
10.3.2.A	General	10-28
10.3.2.B	Guidelines for Moment Slab Design	10-28
10.3.2.B.1	Structural Capacity	10-28
10.3.2.B.2	Global Stability	10-29
10.3.2.B.3	Minimum and Maximum Dimensions	10-29
10.3.2.B.4	Sliding of the Barrier	10-29
10.3.2.B.5	Overturning of the Barrier	10-30
10.3.2.C	Guidelines for the Soil Reinforcement	10-31
10.3.2.D	Design of the Wall Panel	10-31
10.3.3	Precast Concrete Barrier	10-31
10.3.3.A	Concrete Barrier Type F and Type 2	10-31
10.3.3.B	Concrete Barrier Type F Narrow Base and Concrete Barrier Type 4	10-32
10.3.4	Miscellaneous Items	10-32
10.4	Bridge Traffic Barrier Rehabilitation	10-33
10.4.1	Policy	10-33
10.4.2	Guidelines	10-33
10.4.3	Design Criteria	10-33
10.4.4	WSDOT Bridge Inventory of Bridge Rails	10-34

10.4.5	Available Retrofit Designs	10-35
10.4.5.A	Washington Thrie Beam Retrofit of Concrete Balusters	10-35
10.4.5.B	Delaware Thrie Beam Guardrail	10-35
10.4.5.C	Concrete Parapet Retrofit	10-35
10.4.5.D	SL-1 Weak Post	10-35
10.4.6	Available Replacement Designs	10-35
10.4.6.A	Traffic Barrier – Shape F Retrofit.	10-35
10.5	Bridge Railing	10-36
10.5.1	Design.	10-36
10.5.2	Railing Types.	10-36
10.5.2.A	Bridge Pedestrian Railing Type BP-10	10-36
10.5.2.B	Bridge Pedestrian Railing Type BP-22	10-36
10.5.2.C	Bridge Pedestrian Railing Type BP-12	10-36
10.5.2.D	Bridge Pedestrian Railing Type BP-54	10-37
10.5.2.E	Bridge Railing Type Snow Fence	10-37
10.5.2.F	Bridge Railing Type Chain Link Fence	10-37
10.6	Bridge Approach Slabs	10-38
10.6.1	Notes to Region for Preliminary Plan	10-39
10.6.2	Bridge Approach Slab Design Criteria	10-39
10.6.3	Bridge Approach Slab Detailing	10-40
10.6.4	Skewed Bridge Approach Slabs	10-40
10.6.5	Approach Anchors and Expansion Joints	10-42
10.6.6	Bridge Approach Slab Addition or Retrofit to Existing Bridges	10-42
10.6.7	Bridge Approach Slab Staging	10-44
10.7	Traffic Barrier on Bridge Approach Slabs	10-45
10.7.1	Bridge Approach Slab over Wing Walls, Cantilever Walls or Geosynthetic Walls.	10-45
10.7.2	Bridge Approach Slab over SE Walls	10-47
10.8	Utilities Installation on New and Existing Structures	10-48
10.8.1	General Concepts.	10-48
10.8.1.A	Responsibilities of the Utility Company	10-48
10.8.1.B	Confined Spaces.	10-48
10.8.1.C	Coating and Corrosion Protection	10-48
10.8.2	Utility Design Criteria	10-51
10.8.2.A	Utility Location.	10-51
10.8.2.B	Termination at the Bridge Ends	10-51
10.8.2.C	Utility Expansion	10-52
10.8.2.D	Utility Blockouts.	10-52
10.8.2.E	Gas Lines or Volatile Fluids.	10-52
10.8.2.F	Water Lines	10-52
10.8.2.G	Sewer Lines.	10-53
10.8.2.H	Electrical (Power and Communications)	10-53

10.8.3	Box/Tub Girder Bridges	10-53
10.8.4	Traffic Barrier Conduit	10-54
10.8.5	Conduit Types	10-54
10.8.6	Utility Supports	10-54
10.8.6.A	Concrete Embedment	10-55
10.8.6.B	Pipe Hangers	10-55
10.8.6.C	Surface Mounting	10-55
10.9	Review Procedure for Utility Installations on Existing Structures	10-56
10.9.1	Utility Review Checklist	10-57
10.10	Anchors for Permanent Attachments	10-58
10.11	Drainage Design	10-59
10.11.1	Geometrics	10-59
10.11.2	Hydrology	10-59
10.11.3	On Bridge Systems	10-59
10.11.4	Construction	10-59
10.12	Bridge Security	10-60
10.12.1	General	10-60
10.12.2	Design	10-60
10.12.3	Design Criteria	10-61
10.13	Temporary Bridges	10-62
10.13.1	General	10-62
10.13.2	Design	10-62
10.13.2.A	One To Two Construction Season Temporary Bridges	10-62
10.13.2.B	Three To Five Construction Season Temporary Bridges	10-62
10.13.2.B.1	Design Requirements	10-62
10.13.2.B.2	Seismic Design Requirements	10-63
10.13.2.B.3	Deck Design Requirements	10-63
10.13.2.B.4	Superstructure Design Requirements	10-63
10.13.2.B.5	Foundation Design Requirements	10-63
10.13.3	NBI Requirements	10-64
10.13.4	Submittal Requirements	10-64
10.14	Bridge Standard Drawings	10-65
10.99	References	10-68

10.1 Sign and Luminaire Supports

10.1.1 Loads

10.1.1.A General

The reference used in developing the following office criteria is the AASHTO LRFD *Standard Specifications for Structural Supports for Highway Signs, Luminaires, and Traffic Signals*, First Edition dated 2015 (including latest interims), and shall be the basis for analysis and design.

10.1.1.B Dead Loads

Sign:

(Including panel and wind beams; does not include vert. bracing) 3.25 lbs/ft²

Luminaire (effective projected area of head = 3.3 sq ft) 60 lbs/each

Fluorescent Lighting 3.0 lbs/ft

Standard Signal Head 60 lbs/each

Mercury Vapor Lighting 6.0 lbs/each/

inch of length

Sign Brackets Calc.

Structural Members Calc.

5 foot wide maintenance walkway:

(Including mounting brackets and handrail) 160 lbs/ft

Signal Head w/3 lenses:

(Effective projected area with backing plate = 9.2 sq ft) 60 lbs/each

10.1.1.C Live Load

A live load consisting of a single load of 500 lb distributed over 2.0 feet transversely to the member shall be used for designing members for walkways and platforms. The load shall be applied at the most critical location where a worker or equipment could be placed, see AASHTO 2015, Section 3.6.

10.1.1.D Wind Loads

A 3 second gust wind speed shall be used in the AASHTO wind pressure equation.

The 3 second wind gust map in AASHTO is based on the wind map in ANSI/ASCE 7-16.

Basic wind speed of 115 mph shall be used in computing design wind pressure using equation 3.8.1-1 of AASHTO Section 3.8.1. This is based on the high risk category with a mean recurrence interval of 1700 years per AASHTO Table 3.8-1.

The Alternate Method of Wind Pressures given in Appendix C of the AASHTO 2015 Specifications shall not be used.

10.1.1.E Fatigue Design

Fatigue design shall conform to AASHTO Section 11 with the exception of square and rectangular tube shape. AASHTO does not provide fatigue calculations for shapes with less than 8 sides. Therefore, calculating the Constant Amplitude Fatigue Threshold, D_T (Table 11.9.3.1-2, AASHTO 2015) was taken to be the larger outer flat to flat distance of the rectangular tube. Fatigue Categories are listed in Table 11.6-1. Overhead Cantilever and Bridge Sign and signal structures, high-mast lighting towers (HMLT), poles, and bridge mounted sign brackets shall conform to the following fatigue categories.

Fatigue Category I: Overhead cantilever sign structures (maximum span of 35 feet and no VMS installation), overhead sign bridge structures, high-mast lighting towers 55 feet or taller in height, bridge-mounted sign brackets, and all signal bridges. Gantry or pole structures used to support sensitive electronic equipment (tolling, weigh-in-motion, transmitter/receiver antennas, transponders, etc.) shall be designed for Fatigue Category I, and shall also meet any deflection limitations imposed by the electronic equipment manufacturers.

Fatigue Category II: For structures not explicitly falling into Category I or III.

Fatigue Category III: Lighting poles less than 55 feet in height with rectangular or square cross sections, or non-tapered round cross sections, and overhead cantilever traffic signals (maximum cantilever length 65 feet).

Sign bridges, cantilever sign structures, signal bridges, and overhead cantilever traffic signals mounted on bridges shall be either attached to substructure elements (e.g., crossbeam extensions) or to the bridge superstructure at pier locations. Mounting these features to bridges as described above will help to avoid resonance concerns between the bridge structure and the signing or signal structure.

CCTV camera pole shall meet deflection criteria specified on Standard Plan J-29-15 for fixed base.

The “XYZ” limitation shown in [Table 10.1.4-2](#) shall be met for Monotube Cantilevers. The “XYZ” limitation consists of the product of the sign area (XY) and the arm from the centerline of the posts to the centerline of the sign (Z). See Appendix 10.1-A2-1 for details.

10.1.1.F Ice and Snow Loads

A 3 psf ice load may be applied around all the surfaces of structural supports, horizontal members, and luminaires, but applied to only one face of sign panels (Section 3.7, AASHTO 2015).

Walk-through VMS shall not be installed in areas where appreciable snow loads may accumulate on top of the sign, unless positive steps are taken to prevent snow build-up.

10.1.1.G Group Load Combinations

Sign, luminaire, and signal support structures are designed using the load factors from Table 3.4-1, AASHTO 2015 (including latest interims).

10.1.1.H Impact Loads

Vehicle impact loads shall be applied to sign, luminaire and traffic signal foundations that are integrated into roadside traffic barriers. The vehicle impact loads shall be applied at the height specified for intended test levels in accordance with the AASHTO LRFD-BDS Section 13 Table A13.2-1 "Design Forces For Traffic Railing (32-inch for TL-4 and 42-inch for TL-5) as modified by Section 10.2.4."

Structural supports for signs, luminaires and traffic signals are normally not designed for the application of vehicle impact loads (with the exception of pole or post-type supports on break-away bases).

10.1.2 Bridge Mounted Signs

10.1.2.A Vertical Clearance

All new signs mounted on bridge structures shall be positioned such that the bottom of the sign or lighting bracket does not extend below the bottom of the bridge as shown in Figure 10.1.2-1. The position of the sign does not need to allow for the future placement of lights below the sign. If lights are to be added in the future they will be mounted above the sign. To ensure that the bottom of the sign or lighting bracket is above the bottom of the bridge, the designer shall maintain at least a nominal 2 inch dimension between the bottom of the sign or lighting and the bottom of the bridge to account for construction tolerances and bracket arm sag.

Bridge mounted sign brackets shall be designed to account for the weight of added lights, and for the wind effects on the lights to ensure bracket adequacy if lighting is attached in the future.

Figure 10.1.2-1 Sign Vertical Clearance

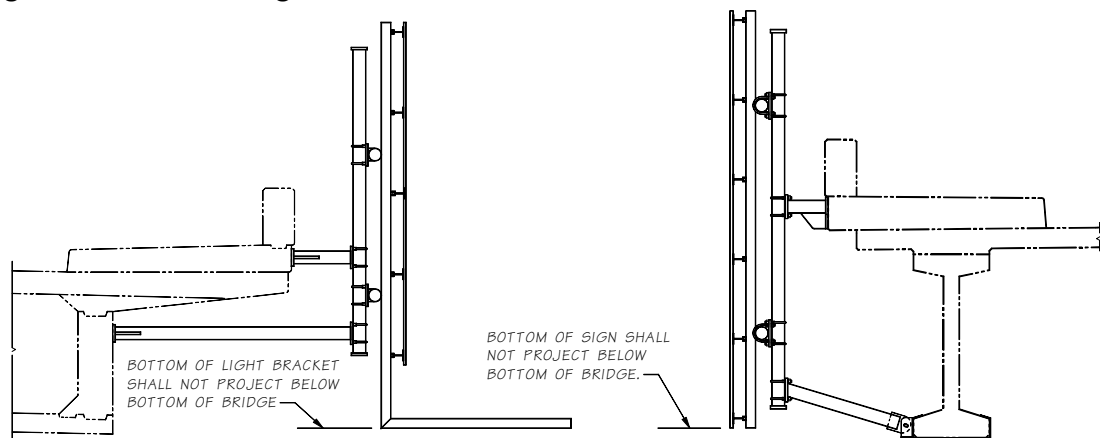

10.1.2.B Geometrics

1. Signs shall be installed at approximate right angles to approaching motorists. For structures above a tangent section of roadway, signs shall be designed to provide a sign skew within 5° from perpendicular to the lower roadway (see Figure 10.1.2-2).

Figure 10.1.2-2 Sign Skew on Tangent Roadway

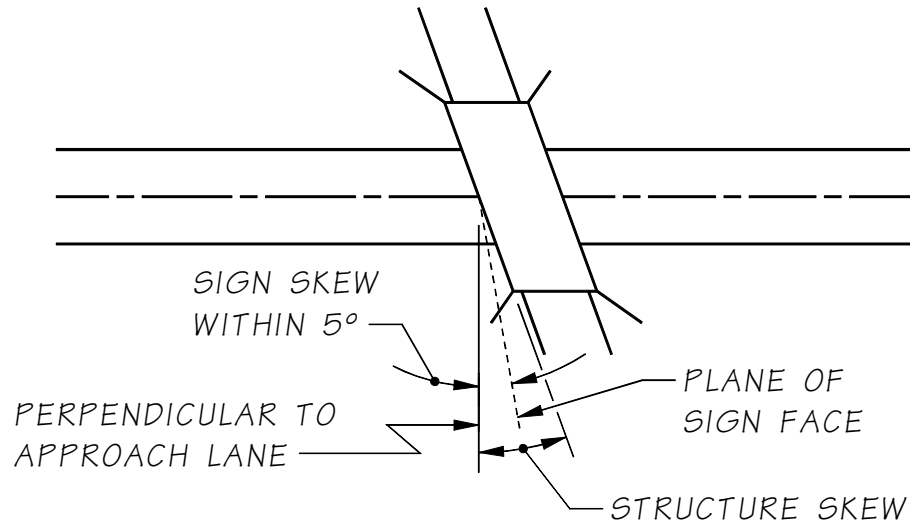

2. For structures located on or just beyond a horizontal curve of the lower roadway, signs shall be designed to provide a sign chord skew within 5° from perpendicular to the chord-point determined by the approach speed (see Figure 10.1.2-3).

Figure 10.1.2-3 Sign Skew on Curved Roadway

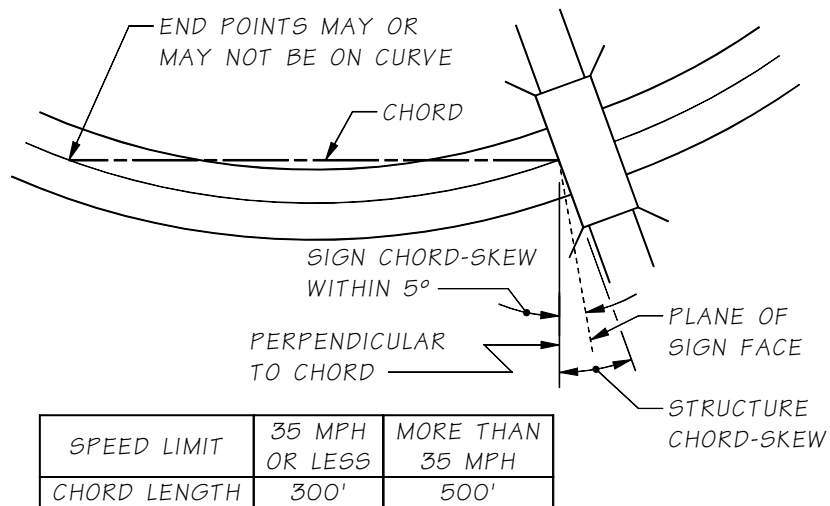

3. The top of the sign shall be level. Maximum sign height shall be decided by the Region. If the structure is too high above the roadway, then the sign shall not be placed on the structure (see Figure 10.1.2-4).

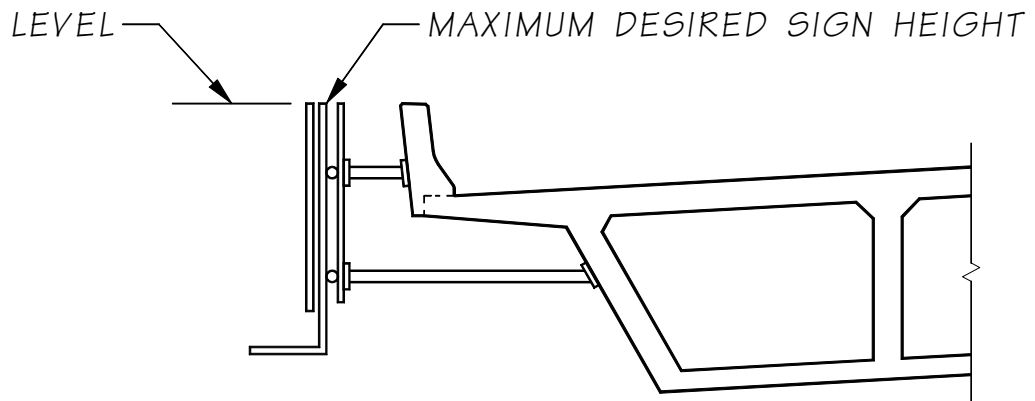
Figure 10.1.2-4

10.1.2.C Aesthetics

1. The support structure shall not extend beyond the limits of the sign unless the extension is unavoidable.
2. The sign support shall be detailed in such a manner that will permit the sign and lighting bracket to be installed level.
3. When the sign support will be exposed to view, special consideration is required in determining member sizes and connections to provide as pleasing an appearance as possible.

10.1.2.D Sign Placement

1. Signs shall not be placed under bridge overhangs. This causes partial shading or partial exposure to the elements and problems in lifting the material into position and making the required connections. Signs shall never be placed directly under the drip-line of the structure. These conditions may result in uneven fading, discoloring, and difficulty in reading.

- A minimum of 2 inches of clearance shall be provided between back side of the sign support and edge of the bridge. See [Figure 10.1.2-5](#).

Figure 10.1.2-5 Sign Horizontal Location

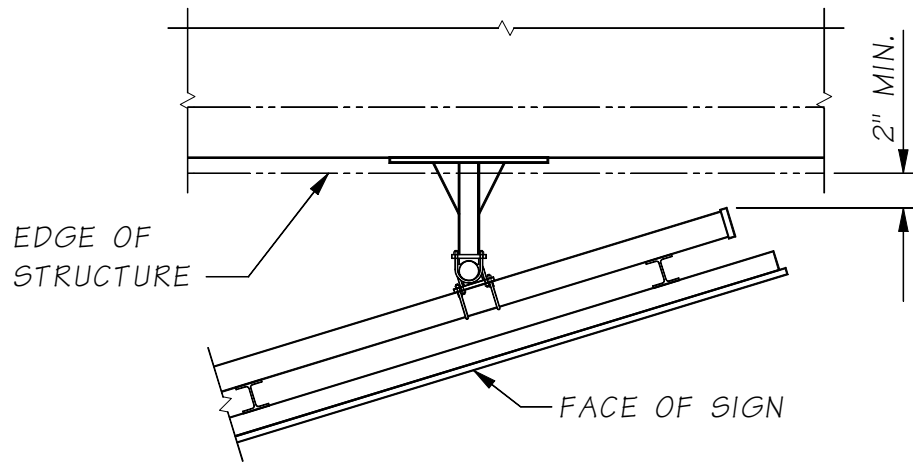

PLAN

- Bridge mounting of wide sign panels on bridges with significant skew will result in excessive bracket arm length. Sign panel width/skew combinations that result in excessive arm lengths shall not be used. Top arm lengths exceeding 7'-0", or any arm length with load demands exceeding the capacity of a 4" diameter standard pipe are considered excessive.
- VMS units shall not be installed on bridge mounted sign brackets.

10.1.2.E Installation

- Adhesive anchors or cast-in-place ASTM F593 Type 304, Group 1 Condition CW, anchor rods shall be used to install the sign brackets on the structure. Size and minimum installation depth shall be given in the plans or specifications. The adhesive anchors shall be installed normal to the concrete surface. Adhesive anchors shall not be placed through the webs or flanges of prestressed or post-tensioned girders unless approved by the WSDOT State Bridge Design Engineer. Adhesive anchors shall not be used at overhead locations other than with horizontal hole/anchor alignment.
- Bridge mounted sign structures shall not be placed on bridges with steel superstructures unless approved by the WSDOT State Bridge Design Engineer.

10.1.2.F Installing/Replacing New Sign on Existing Bracket Supports

When installing a new sign on existing bracket supports, the following shall be required:

1. All hardware shall be replaced per the current *Standard Specifications*.
2. The new sign area shall not exceed the original designed sign area.
3. The inspection report for the bracket shall be reviewed to ensure that the supports are in good condition. If there is not an inspection report, then an inspection shall be performed on the bracket.

10.1.2.G Detailing

For standard bridge mounted sign bracket details see Bridge Standard Drawings [10.1-A6-1](#) to [10.1-A6-5](#). All information shown in the Layout (Bridge Standard Drawing [10.1-A6-1](#)) shall be included on the contract plans. This is provided to allow WSDOT sign inspectors to locate and identify the sign and bridge with the as-built layout.

When attaching the lower bracket arm to concrete I-girders, concrete, box/tub girders, or steel I-girders, use Bridge Standard Drawing [10.1-A6-4A](#), [10.1-A6-4B](#), or [10.1-A6-4C](#), respectively.

10.1.3 Monotube Sign Structures Mounted on Bridges

10.1.3.A Design Loads

Design loads for the supports of the Sign Bridges shall be calculated based on assuming a 12-foot-deep sign over the entire roadway width, under the sign bridge, regardless of the sign area initially placed on the sign bridge. For Cantilever design loads, guidelines specified in Section 10.1.1 shall be followed. The design loads shall follow the same criteria as described in Section 10.1.1. Loads from the sign bridge shall be included in the design of the supporting bridge.

In cases where a sign structure is mounted on a bridge, the sign structure, from the anchor bolt group and above, shall be designed to AASHTO LRFD *Standard Specifications for Structural Supports for Highway Signs, Luminaires, and Traffic Signals* First Edition, dated 2015 including interims. The concrete, the anchor bolt group, and the connecting elements to the bridge structure shall be designed to the specifications in this manual and AASHTO LRFD. The loads calculated from the AASHTO LRFD Specifications for Structural Supports for Signs, Luminaires and Traffic Signals (AASHTO SLTS) shall be considered as Service Loads (LF = 1.0). These Service Loads shall be factored as required for the Strength and Extreme Limit States described in AASHTO LRFD Table 3.4.1-1, and used for design of sign structure foundation elements incorporated into new structures. For sign structure foundation elements attached to older structures originally designed using Allowable Stress Design, the loads calculated using AASHTO SLTS may be considered as Service Loads.

10.1.3.B Vertical Clearance

Vertical clearance for Monotube Sign Structures shall be 20'-0" minimum from the bottom of the lowest sign to the highest point in the traveled lanes. See Appendix 10.1-A1-1, 10.1-A2-1, and 10.1-A3-1 for sample locations of Minimum Vertical Clearances.

10.1.3.C Geometrics

Sign structures shall be placed at approximate right angles to approaching motorists. Dimensions and details of sign structures are shown in Appendix 10.1-A1-1, 10.1-A1-2, and 10.1-A1-3 and 10.1-A2-1, 10.1-A2-2, and 10.1-A2-3. When maintenance walkways are included, refer to Standard Plans G-95.10, G-95.20, G-95.30.

10.1.4 Monotube Sign Structures

10.1.4.A Sign Bridge Conventional Design

Table 10.1.4-1 provides the conventional structural design information to be used for a Sign Bridge Layout, Bridge Standard Drawing 10.1-A1-1; along with the Structural Detail sheets, which are Bridge Standard Drawing 10.1-A1-2 and Bridge Standard Drawing 10.1-A1-3; General Notes, Bridge Standard Drawing 10.1-A5-1; and Miscellaneous Details, Bridge Standard Drawing 10.1-A5-2.

10.1.4.B Cantilever Conventional Design

Table 10.1.4-2 provides the conventional structural design information to be used for a Cantilever Layout, Bridge Standard Drawing 10.1-A2-1; along with the Structural Detail sheets, which are Bridge Standard Drawing 10.1-A2-2 and Bridge Standard Drawing 10.1-A2-3; General Notes, Bridge Standard Drawing 10.1-A5-1; and Miscellaneous Details, Bridge Standard Drawing 10.1-A5-2.

Table 10.1.4-1 Standard Monotube Sign Bridges

SPAN LENGTH	POSTS [Ⓢ]				BEAM A [Ⓢ]				BEAM B [Ⓢ]				BEAM C [Ⓢ]				BEAM D [Ⓢ]				CAMBER
	"S"	"H"	"A"	"B"	"T1"	"L1"	"B"	"C"	"T2"	"L2"	"B"	"C"	"T2"	"L3"	"B"	"C"	"T2"	"L3"	"B"	"C"	
LESS THAN 60'-0"	30'-0" OR LESS	1'-6"	2'-0"	1/2"	6'-0"	2'-0"	2'-0"	1/2"	0'-0"	2'-0"	2'-0"	1/2"	13'-0" TO 48'-0"	2'-0"	2'-0"	1/2"	-	-	-	-	2 3/4"
60'-0" TO 75'-0"	30'-0" OR LESS	1'-6"	2'-3"	5/8"	6'-0"	2'-3"	2'-0"	5/8"	9'-0" TO 14'-0"	2'-3"	2'-0"	5/8"	30'-0" TO 35'-0"	2'-3"	2'-0"	5/8"	-	-	-	-	3 3/4"
+75'-0" TO 90'-0"	30'-0" OR LESS	1'-6"	2'-3"	5/8"	6'-0"	2'-3"	2'-0"	5/8"	14'-0" TO 19'-0"	2'-3"	2'-0"	5/8"	35'-0" TO 40'-0"	2'-3"	2'-0"	5/8"	-	-	-	-	5"
+90'-0" TO 105'-0"	30'-0" OR LESS	1'-9"	2'-6"	5/8"	6'-0"	2'-6"	2'-3"	5/8"	19'-0" TO 26'-6"	2'-6"	2'-3"	5/8"	40'-0"	2'-6"	2'-3"	5/8"	-	-	-	-	6"
+105'-0" TO 120'-0"	30'-0" OR LESS	1'-9"	2'-6"	5/8"	6'-0"	2'-6"	2'-3"	5/8"	16'-6" TO 34'-0"	2'-6"	2'-3"	5/8"	40'-0"	2'-6"	2'-3"	5/8"	-	-	-	-	7 1/2"
+120'-0" TO 135'-0"	30'-0" OR LESS	2'-0"	2'-8"	5/8"	6'-0"	2'-8"	2'-8"	5/8"	34'-0" TO 41'-6"	2'-8"	2'-8"	5/8"	40'-0"	2'-8"	2'-8"	5/8"	-	-	-	-	8 1/2"
+135'-0" TO 150'-0"	30'-0" OR LESS	2'-0"	2'-8"	5/8"	6'-0"	2'-8"	2'-8"	5/8"	41'-6" TO 49'-0"	2'-8"	2'-8"	5/8"	40'-0"	2'-8"	2'-8"	5/8"	-	-	-	-	10 1/2"
+150'-0" TO 165'-0"	30'-0" OR LESS	2'-0"	2'-8"	3/4"	6'-0"	2'-8"	2'-8"	5/8"	27'-0"	2'-8"	2'-8"	5/8"	18'-5" TO 25'-6"	2'-8"	2'-8"	5/8"	48'-0"	2'-8"	2'-8"	5/8"	13 3/4"
+165'-0" TO 180'-0"	30'-0" OR LESS	2'-0"	2'-8"	3/4"	6'-0"	2'-8"	2'-8"	5/8"	30'-0"	2'-8"	2'-8"	5/8"	22'-6" TO 30'-0"	2'-8"	2'-8"	5/8"	48'-0"	2'-8"	2'-8"	5/8"	15 3/4"

SPAN LENGTH	POST BASE [Ⓢ]					BOLTED SPLICE #1 L1 TO L2 AND L1 TO L3					BOLTED SPLICE #2 L2 TO L3					BOLTED SPLICE #3 L3 TO L4					MAXIMUM SIGN AREA			
	"D1"	"S5"	"S6"	"T3"	"T6"	"S1"	"S2"	"S3"	"S4"	"T4"	"T5"	"S1"	"S2"	"S3"	"S4"	"T4"	"T5"	"S1"	"S2"	"S3"		"S4"	"T4"	"T5"
LESS THAN 60'-0"	1 1/2"	4	4	3"	3/4"	5	-	5	-	2"	5/8"	-	-	-	-	-	-	-	-	-	-	-	-	600 SQ. FT.
60'-0" TO 75'-0"	1 3/4"	4	4	3"	3/4"	6	-	5	-	2"	5/8"	6	-	5	-	2 1/4"	3/4"	-	-	-	-	-	-	700 SQ. FT.
+75'-0" TO 90'-0"	1 3/4"	4	4	3"	3/4"	6	-	5	-	2"	5/8"	6	-	5	-	2 1/4"	3/4"	-	-	-	-	-	-	800 SQ. FT.
+90'-0" TO 105'-0"	1 3/4"	4	5	3"	1"	7	-	6	-	2"	5/8"	7	5	6	4	2 1/2"	1"	-	-	-	-	-	-	900 SQ. FT.
+105'-0" TO 120'-0"	1 3/4"	4	5	3"	1"	7	-	6	-	2"	5/8"	7	5	6	4	2 1/2"	1"	-	-	-	-	-	-	900 SQ. FT.
+120'-0" TO 135'-0"	2"	4	5	3"	1"	7	5	7	5	2"	5/8"	7	5	7	5	2 1/2"	1"	-	-	-	-	-	-	900 SQ. FT.
+135'-0" TO 150'-0"	2"	4	5	3"	1"	7	5	7	5	2"	5/8"	7	5	7	5	2 1/2"	1"	-	-	-	-	-	-	900 SQ. FT.
+150'-0" TO 180'-0"	2"	4	5	3"	1"	7	5	7	5	2"	5/8"	7	5	7	5	2 1/2"	1"	7	5	7	5	2 1/2"	1"	900 SQ. FT.

Ⓢ DENOTES MAIN LOAD CARRYING TENSILE MEMBERS OR TENSION COMPONENTS OF FLEXURAL MEMBERS.

Table 10.1.4-2 Standard Monotube Cantilevers

Span Length	Posts ⊙				Beam A ⊙				Beam B ⊙				Camber
"S"	"H"	"A"	"B"	"T1"	"L1"	"B"	"C"	"T2"	"L2"	"B"	"C"	"T2"	
Less Than 20'-0"	30'-0" or Less	1'-6"	2'-0"	½"	6'-0"	2'-0"	2'-0"	½"	14'-0"	2'-0"	2'-0"	½"	2"
20'-0" to 35'-0"	30'-0" Or Less	1'-6"	2'-0"	½"	6'-0"	2'-0"	2'-0"	½"	14'-0" TO 29'-0"	2'-0"	2'-0"	½"	3½"

Span Length	Post Base ⊙					Bolted Splice						Maximums		
"S"	"D1"	"S5"	"S6"	"T3"	"T6"	"S1"	"S2"	"S3"	"S4"	"T4"	"T5"	Sign Area	"XYZ"	"Z"
Less Than 20'-0"	1½"	4	4	2"	¾"	5	-	5	-	2"	⅝"	194 SQ. FT.	2920 C.F.	15'-0"
20'-0" to 30'-0"	2"	4	4	3"	¾"	5	3	5	3	2½"	⅝"	330 SQ. FT.	5363 C.F.	20'-0"
+30'-0" to 35'-0"	2"	4	4	3"	¾"	5	3	5	3	2½"	⅝"	235 SQ. FT.	5924 C.F.	25'-0"

⊙ **Note:** Denotes Main Load Carrying Tensile Members Or Tension Components Of Flexural Members.

10.1.4.C Balanced Cantilever Conventional Design

Bridge Standard Drawing [10.1-A3-1](#); along with the Structural Detail sheets, Bridge Standard Drawing [10.1-A3-2](#) and [10.1-A3-3](#), General Notes, Bridge Standard Drawing [10.1-A5-1](#); and Miscellaneous Details, Bridge Standard Drawing [10.1-A5-2](#), provides the conventional structural design information to be used for a Balanced Cantilever Layout. Balanced Cantilevers are typically for VMS sign applications and shall have the sign positioned so that no less than ⅓ of the sign dead load resides on either side of the post.

10.1.4.D VMS Installation

1. VMS units shall not be installed on unbalanced cantilever structures.
2. VMS installation on Sign Bridge structures designed in accordance with AASHTO 2015 shall be installed in accordance with the following:
 - A. On spans 120 ft and greater up to two VMS units may be installed with a maximum weight of 4,000 lbs each. Maintenance walkways may be installed between VMS units, but may not exceed 160 lbs/ft, or exceed 50 percent of the structure span length.
 - B. On spans less than 120 ft. up to three VMS units may be installed with a maximum weight of 4,000 lbs. each. Maintenance walkways may be installed between VMS units, but may not exceed 160 lbs/ft.
3. The number of VMS installed on Sign Bridge structures designed prior to AASHTO 2015 shall be reduced by one as defined in D.2-a and b.

10.1.4.E Monotube Sheet Guidelines

The following guidelines apply when using the Monotube Sign Structure Bridge Standard Drawing 10.1-A1-1, 10.1-A1-2, and 10.1-A1-3; 10.1-A2-1, 10.1-A2-2, and 10.1-A2-3; 10.1-A3-1, 10.1-A3-2, and 10.1-A3-3; 10.1-A4-1, 10.1-A4-2, and 10.1-A4-3; and 10.1-A5-1, 10.1-A5-2, and 10.1-A5-3.

1. Each sign structure shall be detailed to specify:
 - A. Sign structure base Elevation, Station, and Number.
 - B. Type of Foundation 1, 2, or 3 shall be used for the Monotube Sign Structures, unless a non-conventional design is required. The average Lateral Bearing Pressure for each foundation shall be noted on the Foundation sheet(s).
 - C. If applicable, label the Elevation View "Looking Back on Stationing."
2. Designers shall verify the cross-referenced page numbers and details are correct.

10.1.4.F Monotube Quantities

Quantities for structural steel are given in Table 10.1.4-3.

Table 10.1.4-3 Sign Structure Material Quantities

ASTM A572 GR. 50 or ASTM 588	Cantilever			Sign Bridge							
	20' <	20' to 30'	Balanced	60' <	60' to 75'	75' to 90'	90' to 105'	105' to 120'	120' to 135'	135' to 150'	150' to 180'
Post (plf)	132	132	132	132	176	176	204	204	215	215	267
Base PL (lbs./ea)	537	806	806	672	735	735	888	888	978	978	1029
Beam, near Post (plf)	152	152	152	152	202	202	228	228	240	240	257
Span Beam (plf)	152	152	152	152	202	202	228	228	240	240	257
Corner Stiff. (lbs./ea set)	209	209	115	218	272	272	354	354	376	376	425
Splice PI #1 (lbs./pair)	592	706	706	578	650	650	826	826	1116	1116	1295
Splice PI #2 (lbs./pair)	--	--	--	--	730	730	1002	1002	1116	1116	1295
Splice PI #3 (lbs./pair)	--	--	--	--	--	--	--	--	--	--	1295
Brackets (lbs./ea)	60	60	60	60	65	65	69	69	70	70	70
6" Hand Hole (lbs./ea)	18	18	18	18	18	18	18	18	18	18	18
6" x 11" Hand Hole (lbs./ea)	30	30	30	30	30	30	30	30	30	30	30
Anchor Bolt PL (lbs./ea)	175	175	175	175	185	185	311	311	326	326	326
Cover Plates (lbs./ea)	65	65	65	--	--	--	--	--	--	--	--

10.1.5 Foundations

10.1.5.A Monotube Sign Structure Foundation Types

The foundation type to be used shall be based on the geotechnical investigation performed and geotechnical report completed by the geotechnical engineer of record. Monotube sign structure foundations are Bridge Design Office conventional designs and shall be as described in the following paragraphs:

1. Foundation Type 1, is the preferred foundation type. A foundation Type 1 consists of a drilled shaft with its shaft cap. The design of the shaft depths shown in the Bridge Standard Drawings are based on an allowable lateral bearing pressure of 2,500 psf. The designer shall check these shaft depths using AASHTO LRFD methodology. For Type 1 foundation details and shaft depths see Bridge Standard Drawings [10.1-A4-1](#) and [10.1-A4-2](#). The Geotechnical Report for Foundation Type 1 should include the soil friction angle, soil unit weight, allowable lateral bearing pressure and temporary casing if required. Temporary casing shall be properly detailed in all Foundation Type 1 sheets if the Geotechnical Engineer requires them.
2. Foundation Type 2 is an alternate to Type 1 when drilled shafts are not suitable to the site. Foundation Type 2 is designed for an allowable lateral bearing pressure of 2,500 psf. See Bridge Standard Drawing [10.1-A4-3](#) for Foundation Type 2 Bridge Design Office conventional design information. The designer shall check these shaft depths using LRFD methodology.
3. Foundation Type 3 replaces the foundation Type 2 for poor soil conditions where the allowable lateral bearing pressure is between 2,500 psf and 1,500 psf. See Bridge Standard Drawing [10.1-A4-3](#) for Type 3 Foundation Bridge Design Office conventional design information. The designer shall check these shaft depths using LRFD methodology.
4. Barrier Shape Foundations are foundations that include a barrier shape cap on the top portion of Foundation Types 1, 2, and 3. Foundation details shall be modified to include Barrier Shape Cap details. Appendix [10.1-A5-1](#) details a single slope barrier.

10.1.5.B Luminaire, Signal Standard, and Camera Pole Foundation Types

Luminaire foundation options are shown on Standard Plan J-28.30. Signal Standard and Camera Pole foundation options are provided on Standard Plans J-26.10 and J-29.10 respectively.

10.1.5.C Foundation Design

Shaft type foundations constructed in soil for sign bridges, cantilever sign structures, luminaires, signal standards and strain poles shall be designed in accordance with the current edition of the AASHTO LRFD *Standard Specifications for Highway Signs, Luminaires, and Traffic Signals*; Section 13.6 Drilled Shafts.

For stratified soil conditions, a weighted average approach should be used to calculate a uniform set of soil properties (soil friction angle, soil unit weight, allowable lateral bearing pressure) for foundation design.

No provisions for foundation torsional capacity are provided in Section 13.6 of the AASHTO LRFD *Standard Specifications for Highway Signs, Luminaires, and Traffic Signals*.

The following approach can be used to calculate torsional capacity of sign structure, luminaire, and signal standard foundations:

Torsional Capacity, ϕT_n ,

$$T_n = F \tan \phi D / 2 \quad 10.1.5(1)$$

Where:

- F = Total force normal to shaft surface (kip)
- D = Diameter of shaft (feet)
- ϕ = Soil to foundation contact friction angle (degree), use smallest for variable soils

10.1.5.C.1 **Monotube Sign Structures Foundation Type 1 Design**

The standard embedment depth “Z”, shown in the table on Monotube Sign Structure Standard Drawing [10.1-A4-1](#), shall be used as a minimum embedment depth and shall be increased if the shaft is placed on a sloped surface. The standard depth assumed that the top 4 feet of the C.I.P. cap is not included in the lateral resistance (i.e., shaft depth “D” in the code mentioned above), but is included in the overturning length of the sign structure. The sign structure shaft foundation GSPs under Section 8-21 in the RFP Appendix shall be included with all Foundation Type 1 shafts.

10.1.5.C.2 **Monotube Sign Structures Foundation Type 2 and 3**

These foundation designs are Bridge Design Office convention and shall not be adjusted or redesigned. They are used in conditions where a Foundation Type 1 (shaft) would be impractical due to difficult drilling or construction and when the State Geotechnical Engineer specifies their use. The concept is that the foundation excavation would maintain a vertical face in the shape of the Foundation Type 2 or 3. Contractors often request to over-excavate and backfill the hole, after formwork has been used to construct this foundation type. This is only allowed with the State Geotechnical Engineer's approval, if the forming material is completely removed, and if the backfill material is either CDF or concrete class 3000 or better.

10.1.5.C.3 **Monotube Sign Structures Non-Conventional Design Foundations**

The Geotechnical Engineer of record shall identify conditions where the foundation types (1, 2, or 3) will not work. In this case, the design forces are calculated, using the *AASHTO LRFD Standard Specifications for Structural Supports for Highway Signs, Luminaires, and Traffic Signals*, and applied at the bottom of the structure base plate. These forces are then considered service loads and the non-conventional design foundation is designed with the appropriate Service, Strength, and Extreme Load Combination Limit States and current design practices of the AASHTO LRFD and this manual. Some examples of these foundations are spread footings, columns and shafts that extend above ground adjacent to retaining walls, or connections to traffic barriers on bridges. The anchor rod array shall be used from Tables 10.1.4-1 and 10.1.4-2 and shall be long enough to develop the rods into the confined concrete core of the foundation. The rod length and the reinforcement for concrete confinement, shown in the top four feet of the Foundation Type 1, shall be used as a minimum.

10.1.5.C.4 **Signal Foundation Design**

The traffic signal standard GSPs under Section 8-20 shall apply for foundations in substandard soils.

10.1.5.D Foundation Quantities

- Barrier quantities are approximate and can be used for all Foundation Types:

Class 4000 Concrete	7.15 CY (over shaft foundation)
Grade 60 Rebar	372 lbs

- Miscellaneous steel quantities (anchor rods, anchor plate, and template) for all Monotube Sign Structure foundation types are listed below (per foundation). Quantities vary with span lengths as shown.

60 feet and under	= 1,002 pounds
61 feet to 90 feet	= 1,401 pounds
91 feet to 120 feet	= 1,503 pounds
121 feet to 180 feet	Barrier mounted sign bridge not recommended for these spans.

- Monotube Sign Structure Foundation Type 1-3 quantities for concrete, rebar and excavation are given in Table 10.1.5-1. For Sign Bridges, the quantities shown below are for one foundation and there are two foundations per Sign Bridge. If the depth "Z" shown in the table on Bridge Standard Drawing [10.1-A4-1](#) is increased, these values should be recalculated.

Table 10.1.5-1 Sign Structure Foundation Material Quantities

Concrete Cl. 4000 (cu. yard)	Cantilever Signs			Sign Bridges			
	20' and Under	20' - 30'	30' - 35'	60' and Under	60' - 90'	90' - 120'	120' - 180'
Type 1	6.3	7.5	9.4	7.7	9.4	10.6	11.4
Type 2	8.0	10.5	12.2	10.0	12.2	14.1	15.0
Type 3	11.1	14.1	16.1	13.0	16.1	18.6	20.0
Rebar Gr. 60 Pounds							
Type 1	685	1,027	2,251	1,168	2,251	3,256	4,255
Type 2	772	1,233	1,724	1,190	1,724	2,385	2,838
Type 3	917	1,509	2,136	1,421	2,136	2,946	3,572
Excavation (cu. yard)							
Type 1	9.8	10.9	12.8	10.9	12.8	14.1	14.9
Type 2	20.7	25.7	29.0	24.6	29.0	32.9	34.6
Type 3	29.0	34.6	39.0	32.9	39.0	44.0	47.8

10.2 Bridge Traffic Barriers

10.2.1 General Guidelines

The design criteria for traffic barriers on structures shall be in accordance with Section 13 of the AASHTO LRFD. The following guidelines supplement the requirements in AASHTO LRFD.

There are three avenues for acceptance for use of roadside safety hardware on bridge traffic barriers and structures as follows:

- Use of a current WSDOT standard¹ within the limits of application as described or implied by that standard.
- Use of a successfully crash tested system to MASH 2016 along with a review by WSDOT which results in the system being accepted for use within Washington State.
- Modifications of WSDOT standards or successfully crash tested systems made with roadside safety considerations and reviewed by WSDOT which results in the modified system being accepted for use within Washington State.

Inclusion of details, configurations, or systems within a standard does not imply or give acceptance for the details, configurations, or systems to be used within Washington State outside of the limits and conditions as described or implied by those standards.

Any details, configurations, or systems approved on a project specific basis may not be used outside the scope or limits of that project without WSDOT review and approval.

The WSDOT Bridge and Structures' standard for traffic barriers on new bridges, bridge approach slabs, **Buried Structures**, retaining walls, Structural Earth Wall traffic barriers, and **Moment Slab** traffic barrier and differential grade median traffic barriers shall be a 42 inch Single Slope concrete barrier for all Interstate, United States Numbered Highway System, and State highway routes unless special conditions apply². The 42 inch height is for **worker** fall protection in accordance with WAC 296-880 and as described in the *Design Manual Chapter 1060 as well as crashworthiness of roadside safety hardware policy*.

Class 1 Buried Structures may use a barrier or railing system in accordance with the *Design Manual Chapter 1610 and Section 8.3.3.G* as applicable. Buried structures which employ a barrier or railing which is not on an approach slab, moment slab, bearing directly on the Buried Structure lid, or structurally integral with the buried structure or other structures may use a barrier or railing system in accordance with *Design Manual Chapter 1610*. In cases meeting the above condition and where the *Design Manual* would not require a barrier or railing system, such as outside of clearzone, provide a minimum TL-2 system on Buried Structures.

¹ Regarding roadside safety elements accepted for use the following are considered WSDOT standards which may require design: WSDOT Standard Plans, WSDOT Bridge Standard Drawings, and barrier systems included within [Section 10.2.3 Available WSDOT Designs](#).

² In effect this means a minimum 42" single slope barrier, minimum test level of TL-4, is required unless special conditions stipulated herein are met or the project receives a unique approval to deviate from the BDM. Examples of special conditions are Class 1 Buried Structures which can allow a lower test level as well as metrics requiring TL-5 which requires a higher test level. When TL-5 is required the 45" single slope barrier is appropriate and does not require unique approval.

All rigid barriers (such as a concrete barrier) shall meet the following requirements in relation to test level.

1. Adequate height to contain the crash test vehicle(s).
2. Has a crashworthy shape.
3. Barrier is determined to be structurally rigid by crash testing or structural analysis.

Adequate height is defined as a minimum of 42", 36", and 32" for TL-5, TL-4, and TL-3 respectively. The heights for TL-5 and TL-4 are from the November 2017 Project No 20-07/Task 395 TTI Project 607141 "Mash Equivalency of NCHRP Report 350-Approved Bridge Railings" Table 4.1, the height for TL-3 is informed by guidance and recommendations from Texas Transportation Institute (TTI) through Pooled Fund correspondence. Placement of hot mix asphalt (HMA) or other material reducing the reveal height below these values downgrades the barriers test level.

For the 32" barrier height, a vertical faced concrete barrier, similar to WSDOT pedestrian barrier, may be used as TL-3 with a minimum height of 29" when connecting to existing infrastructure or when site distance conflicts exist.

The WSDOT Bridge and Structures standard for existing bridges, bridge rehabilitation projects, and median barrier shall be a 34 inch or 42 inch Single Slope traffic barrier.

Use of a 32 inch or 42 inch F Shape concrete barrier shall be limited to locations where there is F Shape concrete barrier on the approach grade to a bridge or for continuity within a corridor.

Use of a 32 inch Pedestrian concrete barrier shall be limited to locations with sidewalk.

Use of a 42 inch or 54 inch combination barrier (32 inch, 34 inch, or 42 inch concrete barrier increased by metal railing) are less economical, require more maintenance, and shall be limited for purposes such as scenic roads. For additional requirements for pedestrian and bicycle/pedestrian railings, see [Section 10.5.1](#).

It shall be the Bridge and Structures Office policy to design traffic barriers for new structures using a minimum Test Level 4 (TL-4) design criteria regardless of the height of the barrier safety shape. The Test Level shall be indicated in the Bridge General Notes or General Notes. A Test Level 5 (TL-5) traffic barrier shall be used on new structures under the following conditions:

- "T" intersections on a structure.
- Barriers on structures with a radius of curvature less than 500 ft, TL-4 is adequate for the barrier on the inside of the curve.
- Greater than 10 percent Average Daily Truck Traffic (ADTT) where approach speeds are 50 mph or greater (e.g., freeway off-ramps).
- Accident history suggests a need.
- Protection of schools, business, or other important facilities below the bridge.

See AASHTO LRFD Section 13 for additional Test Level selection criteria.

10.2.2 Bridge Railing Test Levels

It must be recognized that bridge traffic barrier performance needs differ greatly from site to site. Barrier designs and costs should match facility needs. This concept is embodied in the AASHTO LRFD. Six different bridge railing test levels, TL-1 thru TL-6, and associated crash test/performance requirements are given in AASHTO LRFD Section 13 along with guidance for determining the appropriate test level for a given bridge. Any reduction in Test Level requires approval by the State Bridge Design Engineer, or the Bridge Barrier Specialist acting upon their behalf.

10.2.3 Available WSDOT Designs

10.2.3.A Service Level 1 (SL-1) Weak Post Guardrail (TL-2)

This bridge traffic barrier is a crash tested weak post rail system. **This system is limited to WSDOT internal use only.** It was developed by Southwest Research Institute and reported in NCHRP Report 239 for low-volume rural roadways with little accident history. This design has been utilized on a number of short concrete spans and timber bridges. A failure mechanism is built into this rail system such that upon a 10 kip applied impact load, the post will break away from the mounting bracket. The thrie beam guardrail will contain the vehicle by virtue of its ribbon strength. This system was designed for a Working Stress design force of 10 kip applied at 22 inches above the deck surface. To ensure minimal or no damage to the bridge deck and stringers, the breakaway connection may be modified for a lower impact load (2 kip minimum) with approval of the State Bridge Design Engineer. The 2 kip minimum equivalent impact load is based on evaluation of the wood rail post strength tested in NCHRP Report 239. The appropriate guardrail approach transition shall be a Case 14 placement as shown on WSDOT [Standard Plan C-2h](#). For complete details see Appendix 10.4-A1-4.

10.2.3.B Texas T-411 Aesthetic Concrete Baluster (TL-2)

Texas developed this standard for a section of highway that was considered to be a historic landmark. The existing deficient concrete baluster rail was replaced with a much stronger concrete baluster that satisfactorily passed the crash test performance criteria set forth by the NCHRP Report 230. For details, visit TXDOT's Bridge and Structures website at www.txdot.gov/inside-txdot/division/bridge.html.

Figure 10.2.3-1

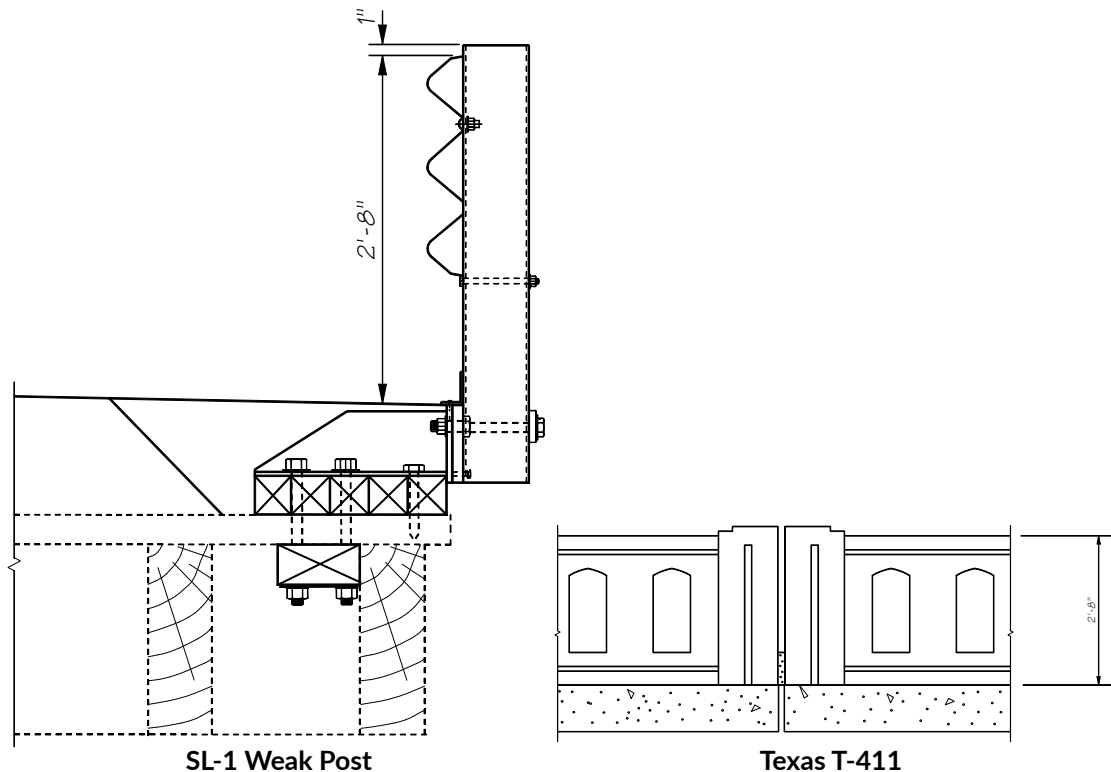

10.2.3.C Traffic Barrier – 32" F-Shape (TL-3)

This configuration was crash tested in the late 1960s, along with the New Jersey Shape, under NCHRP 230 and again at this test level under NCHRP 350. The steeper vertical shape tested better than the New Jersey face and had less of an inclination to roll vehicles over upon impact. For future deck overlays, an encroachment of 2.0 in., leaving a 1.0 in. lip has been satisfactorily tested for safety shapes, see AASHTO Article C13.7.3.2. This barrier height will require the use of a Bridge Railing Type Pedestrian railing to meet fall protection requirements. For complete details see [Bridge Standard Drawings 10.2-A1](#) and [10.2-A2](#).

10.2.3.D Traffic Barrier – 34" Single Slope (TL-3)

This concrete traffic barrier system was designed by the state of California in the 1990s to speed up construction by using the "slip forming" method of construction. It was tested under NCHRP 350. WSDOT has increased the height from 32" to 34" to match the approach traffic barrier height and to allow the placement of one HMA overlay. Due to inherent problems with the "slip forming" method of traffic barrier construction WSDOT has increased the concrete cover on the traffic side from 1½" to 2½". This barrier height will require the use of a Bridge Railing Type Pedestrian railing to meet fall protection requirements. For complete details, see [Bridge Standard Drawing 10.2-A3](#).

Figure 10.2.3-2

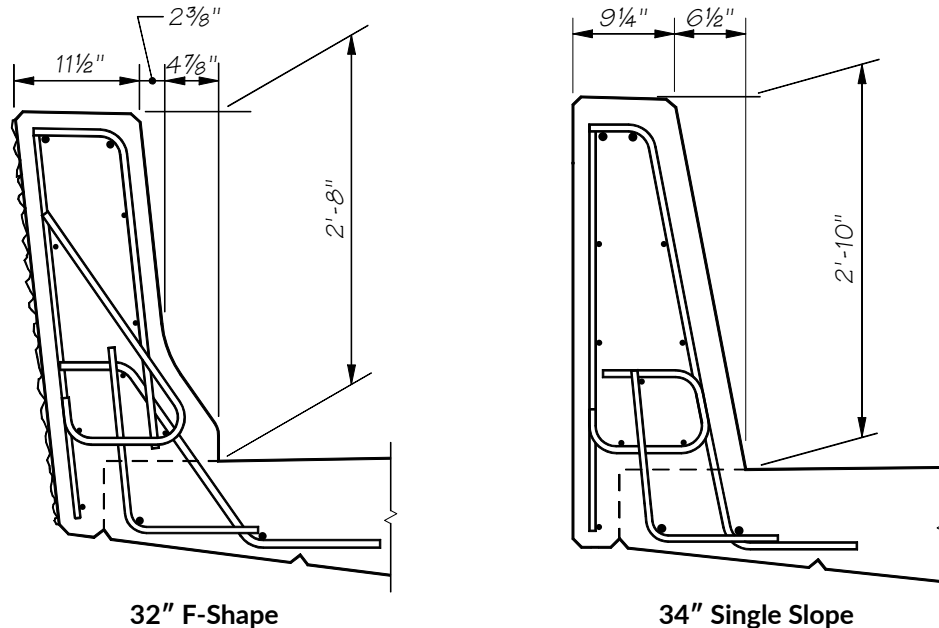

10.2.3.E Pedestrian Barrier (TL-3)

This crash tested rail system offers a simple to build concrete alternative to the New Jersey and F-Shape configurations. This system was crash tested under both NCHRP 230 and 350. Since the traffic face geometry is better for pedestrians and bicyclists, WSDOT uses this system primarily in conjunction with a sidewalk. This barrier height will require the use of a Bridge Railing Type Pedestrian railing to meet fall protection requirements. For complete details, see [Bridge Standard Drawing 10.2-A4](#).

The Pedestrian Barrier has been reduced from a TL-4 barrier to a TL-3 barrier due to its height of 32" being less than adequate to contain the design vehicle when compared to MASH criteria. The intent is to design this barrier as a TL-4 barrier, even though its classification does not meet TL-4 due to the height. On projects which have a minimum of 5' of raised sidewalk from the barrier face to traffic **and traffic speeds less than or equal to 35 mph** or a TL-4 barrier protecting the Pedestrian Barrier from traffic, it is permissible to use this barrier for new construction as a TL-3. For instances absent a TL-4 barrier or sidewalk **and speed** as described, a unique barrier design with a minimum overall **concrete** height of 36" is required to meet the TL-4 criteria. It is permissible and accepted for use within Washington State to use a custom designed Pedestrian barrier for TL-4 use.

10.2.3.F Oregon 3-Tube Curb Mounted Traffic Barrier (TL-4)

This is another crash tested traffic barrier that offers a lightweight, see-through option. This system was successfully crash tested under Mash 2016 for TL-4 conditions. When using this barrier, it is appropriate to use ODOT's transition details. A rigid thrie beam guardrail transition is required at the bridge ends, either directly connected to the three tube or through use of a concrete end block. For details, see the Oregon Bridge and Structure website at www.oregon.gov/ODOT/HWY/ENGSERVICES/Pages/bridge_drawings.aspx.

Figure 10.2.3-3

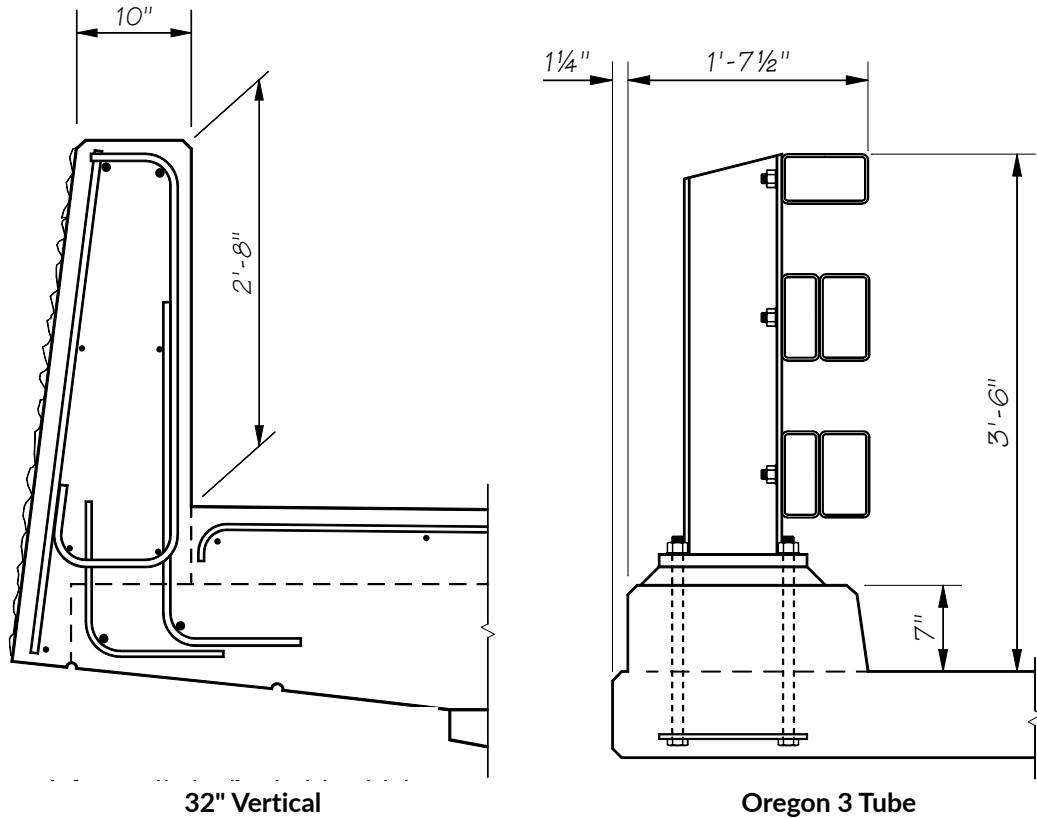

10.2.3.G Traffic Barrier – 42" and 45" F-Shape (TL-4 and TL-5)

This barrier is very similar to the 32" F-shape concrete barrier in that the slope of the front surface is the same except for height. For complete details, see Bridge Standard Drawing and Standard Plan C81.10.

The intent is for TL-5 barrier systems to employ a 45" height to accommodate a future overlay while still meeting TL-5 requirements for minimum 42" height. At the time of publication, the standard drawings have not yet been updated. Reach out to BSO staff for 45" detailing if a TL-5 system is employed prior to the standard drawings being updated.

10.2.3.H Traffic Barrier – 42" and 45" Single Slope (TL-4 and TL-5)

This option offers a simple to build alternative to the Shape F configuration. For complete details see Bridge Standard Drawing 10.2-A6 and Standard Plan C81.10.

The intent is for TL-5 barrier systems to employ a 45" height to accommodate a future overlay while still meeting TL-5 requirements for minimum 42" height. At the time of publication, the standard drawings have not yet been updated. Reach out to BSO staff for 45" detailing if a TL-5 system is employed prior to the standard drawings being updated.

Figure 10.2.3-4

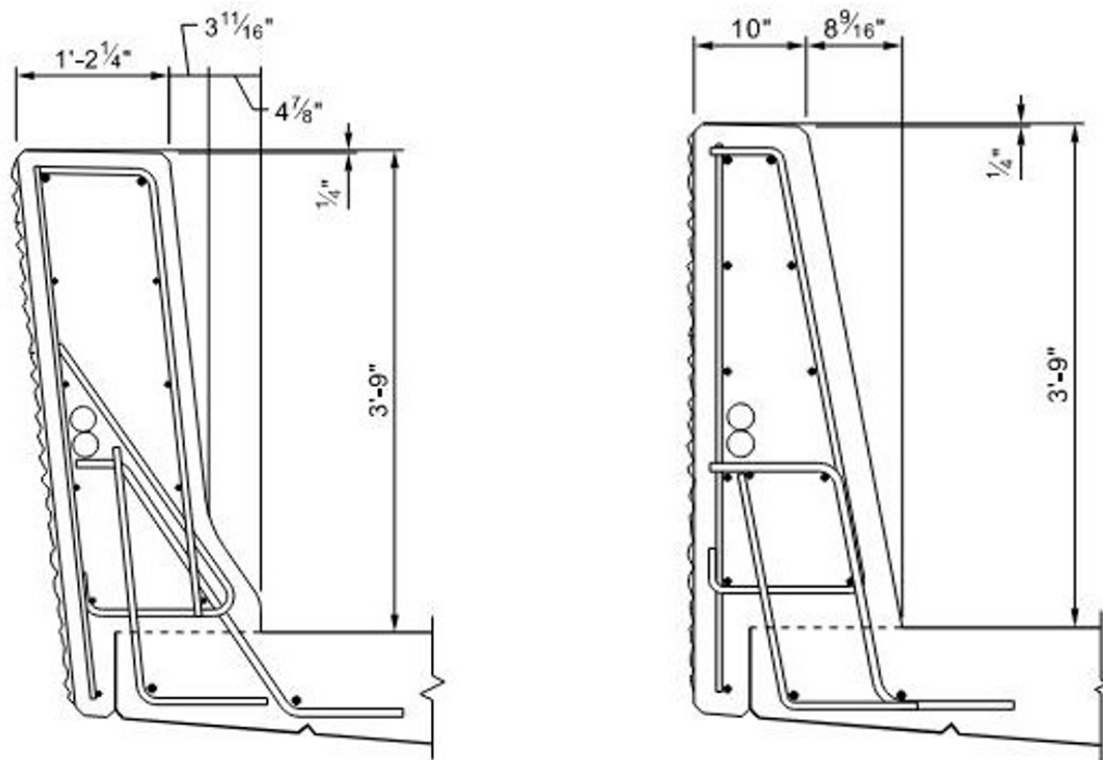
**42" F-Shape****42" Single Slope**

10.2.4 Design Criteria

10.2.4.A Design Values

AASHTO LRFD-BDS Appendix A13, as modified by the BDM, shall be used to design bridge traffic barriers and their supporting elements (i.e. the deck).

All concrete TL-4 barriers and their supporting structures shall employ design metrics from the following table 10.2.4-1 which governs over AASHTOLRFD-BDS table A13.2-1.

Table 10.2.4-1 TL-4 Concrete Barrier Design Parameters

Design Parameters	Barrier Reveal Height (in.)			
	36	39	42	>45
Impact Force, F_t (kips)	67.2	72.3	79.1	93.3
Friction Force, F_L (kips)	21.6	23.6	26.8	27.5
Vertical Force, F_v (kips)	37.8	32.7	22.0	N/A
Length of Force, L_t and L_L (ft)	4.0	5.0	5.0	14.0
Effective Load Height, H_e (in.)	25.1	28.7	30.2	45.5

N/A – Not Applicable

Values for intermediate heights between 36" and 42" may interpolate between the values in the table. The 42" height values may be used for reveal heights up to 45".

Concrete traffic barriers shall be designed using yield line analysis as described in AASHTO LRFD-BDS A13.3.1. The impact loads on traffic barriers shall be applied at the height specified for intended Test Levels in accordance with the AASHTO LRFD-BDS Table A13.2-1 "Design Forces for Traffic Railing", as modified in this section. WSDOT Standard F Shape, Single Slope, and Pedestrian barriers meet these requirements.

Deck overhangs supporting traffic barriers shall be designed in accordance with AASHTO LRFD-BDS A13.4 as modified in this section. For concrete traffic barriers in Design Case 1, AASHTO requires M_s , the deck overhang flexural resistance, to be greater than M_c of the concrete traffic barrier base. This requirement is consistent with yield line analysis (see AASHTO LRFD CA13.3.1), but results in over conservative deck overhang designs.

In order to prevent this unnecessary overdesign of the deck overhang, the nominal traffic barrier resistance to transverse load R_{Wv} (AASHTO LRFD-BDS A13.3.1) transferred from the traffic barrier to deck overhang shall not exceed 120 percent of the design force F_t (AASHTO LRFD-BDS Table A13.2-1 and BDM Table 10.2.4-1) required for a traffic barrier. The deck overhang shall be designed in accordance with the requirements of AASHTO LRFD-BDS A13.4.2 to provide a flexural resistance M_s , acting coincident with the tensile force T. At the inside face of the barrier M_s may be taken as:

$$\text{for an interior barrier segment} - M_s = \frac{R_w \cdot H_e}{L_C + 2 \cdot H}$$

$$\text{and for an end barrier segment} - M_s = \frac{R_w \cdot H_e}{L_C + H}$$

However, M_s need not be taken greater than M_c at the base. T shall be taken as:

$$\text{for an interior barrier segment} - T = \frac{R_w}{L_C + 2 \cdot H}$$

$$\text{and for an end barrier segment} - T = \frac{R_w}{L_C + H}$$

The end segment requirement may be waived if continuity between adjacent barriers is provided.

When an HMA overlay is required for initial construction, increase the **height** for traffic barrier. See [Section 10.2.4.C](#) for details.

10.2.4.B Geometry

The traffic face geometry is part of the crash test and shall not be modified. **A single slope face is the WSDOT standard, see [Section 10.2.1](#).** Contact the WSDOT Bridge and Structure Office Bridge Rail Specialist for further guidance.

Thickening of the traffic barrier is permissible for architectural reasons. **Architectural modifications to continuous runs of barrier should not significantly increase the stiffness of the barrier. Thickening which does significantly increase the stiffness should be limited to localized areas associated with the architectural feature. All unique features, modifications, or barriers require design inclusive of load path to connected element.**

Concrete clear cover must meet minimum concrete cover requirements but can be increased to accommodate rustication grooves or patterns.

Thickening of the traffic barrier is permissible to accommodate roadside features such as sign bridges, luminaires, or similar elements. See [Section 10.2.1](#) for process for acceptance for use within the state of Washington.

10.2.4.C Standard Detail Sheet Modifications

When designing and detailing a bridge traffic barrier on a superelevated bridge deck the following guidelines shall be used:

- For bridge decks with a superelevation of 8 percent or less, the traffic barriers (and the median barrier, if any) shall be oriented perpendicular to the bridge deck.
- For bridge decks with a superelevation of more than 8 percent, the traffic barrier on the low side of the bridge (and median barrier, if any) shall be oriented perpendicular to an 8 percent superelevated bridge deck. For this situation, the traffic barrier on the high side of the bridge shall be oriented perpendicular to the bridge deck.

Type F safety shape notes:

- **The toe of the barrier, defined as the vertical portion of the traffic facing side of the barrier, shall be a maximum of 3" when exposed to traffic.**
- **Overlays shall not rise higher than the barrier toe, the toe of the barrier may be covered by a future overlay.**
- **Use of barrier toes >3" to account for an overlay present from day 1 open to traffic require unique design for the barrier and deck connection.**

The standard detail sheets are generic and may need to be modified for each project. **See [Section 10.2.1](#) for the process for unique modifications.** The permissible modifications are:

- Removal of the electrical conduit, junction box, and deflection fitting details.
- Removal of design notes.
- **Removal of non-applicable elements such as transitions not used or barrier on wall or other supporting structure not present in the project.**
- Increase the 3" toe dimension of the Shape F traffic barriers up to 6" to accommodate HMA overlays **present on day 1 open to traffic.**

10.2.4.D Miscellaneous Design Information

- Show the back of pavement seat in the “Plan – Traffic Barrier” detail.
- At roadway expansion joints, show traffic barrier joints normal to centerline except as shown on sheets [Appendix 9.1-A1-1](#) and [9.1-A2-1](#).
- When an overlay is required or intended, the adequate height to contain the test vehicle from [BDM Section 10.2.1](#) shall be provided in the post overlay condition, or the barrier does not qualify for the given test level.
- When bridge lighting, sign bridges, or other appurtenances are a part of the contract, include the associated details and connection sheets.
- Approximate quantities for the traffic barrier sheets on an 8” thick deck including the tail and a representative ½” of concrete for the fractured fin finish are:

Barrier Type	Weight (lb/ft)	\bar{x} (in)*
32" F-shape (3" toe)	481	4.12
34" Single Slope	517	5.80
42" F-shape (3" toe)	734	4.91
42" Single Slope	703	6.61
45" F-shape (3" toe)	782	4.75
45" Single Slope	764	6.80
32" Pedestrian	640**	

Using concrete class 4000 with a unit weight of 155 lb/ft³

* \bar{x} is measured from the back face of barrier or for type f the back face of barrier at deck level.

** with 6" sidewalk, will vary with sidewalk thickness, legacy numbers from prior calculation.

- Steel Reinforcement Bars:

S_1 & S_2 or S_3 & S_4 and W_1 & W_2 bars (if used) shall be included in the Bar List. S_1 , S_3 , and W_1 bars shall be epoxy coated.

Table 10.2.4-2 Barrier Impact Design Forces on Traffic Barrier & Deck Overhang

Parameters	Type F 32 in. (TL-3) ¹		Single Slope 34 in. (TL-3) ¹		Type F 42 in. (TL-4)		Single Slope 42 in. (TL-4)		Type F 45 in. (TL-5)		Single Slope 45 in. (TL-5)	
	Interior	End ²	Interior	End ²	Interior	End ²	Interior	End ²	Interior	End ²	Interior	End ²
Standard Reference	10.2-A1-1 to 3		10.2-A3-1 to 3		10.2-A5-1A to 3		C-81.10		10.2-A5-1 to 3		10.2-A6-1B to 3	
Average M_c (ft-kips/ft)	20.62	20.62	19.39	19.39	26.02	26.02	22.49	22.49	25.95	25.95	23.08	37.12
M_c at Base (ft-kips/ft)	27.24	27.24	26.11	26.11	32.97	32.97	30.76	30.76	32.97	32.97	31.94	51.61
M_w (ft-kips)	42.61	46.23	46.29	43.42	72.96	72.14	54.77	53.02	98.41	97.11	83.97	81.34
L_c (ft)	8.62	4.76	9.62	5.22	11.71	6.49	11.13	6.31	15.39	9.48	15.19	8.92
R_w (kips)	133.24	73.56	131.72	71.41	174.05	96.55	143.02	81.08	213.04	131.22	186.96	176.61
F_1 (kips)	54.00	54.00	54.00	54.00	79.10	79.10	79.10	79.10	124.00	124.00	124.00	124.00
H_e (in)	5	5	5	5	30.20	30.20	30.20	30.20	5	5	5	5
L_1 and L_2 (ft)	5	5	5	5	5.00	5.00	5.00	5.00	5	5	5	5
1.2^*F_1 (kips)	64.80	64.80	64.80	64.80	94.92	94.92	94.92	94.92	148.80	148.80	148.80	148.80
Design R_w (kips)	64.80	64.80	64.80	64.80	94.92	94.92	94.92	94.92	148.80	148.80	148.80	148.80
$R_w^*H_e/(L_c+aH)$ (ft-kips/ft) ⁴	12.39	23.28	11.30	21.47	12.77	23.90	18.33	28.93	22.75	34.71	22.96	41.10
Design M_s (ft-kips/ft)	12.39	23.28	11.30	21.47	12.77	23.90	13.19	20.79	22.75	32.97	22.96	41.10
Design T (kips/ft)	4.65	8.73	4.24	8.05	5.07	9.50	5.24	8.26	6.50	9.92	6.56	11.74
A_s required (in ² /ft)	0.29	0.57	0.27	0.53	0.23	0.43	0.27	0.43	0.41	0.61	0.45	0.83
A_s provided (in ² /ft) ⁶	0.41	0.62	0.41	0.62	0.41	0.62	0.28	0.53	0.59	0.88	0.66	0.96
Deck to Barrier Reinf.	#5 @ 9 in		#5 @ 9 in		#5 @ 9 in		#5 @ 13.5 in		#6 @ 9 in		#6 @ 8 in #6 @ 5.5 in	

- 1 These barriers are downgraded to TL-3 due to insufficient height to contain the test vehicle. Their design is based on TL-4 metrics from AASHTO chapter 13 and A13.
- 2 Traffic barrier dimensions and reinforcement used for calculation reflect WSDOT standard drawings or standard plans. Modifications shall be calculated per AASHTO-LRFD Chapter 13, A13, and the WSDOT BDM.
- 3 TL-4 barriers are designed to the updated forces from WSDOT BDM Chapter 10, which governs over AASHTO Chapter 13 for these barriers.
- 4 $a = 1$ for an end segment and 2 for an interior segment.
- 5 AASHTO Table A13.2-1 with H_e taken as H_g (min).
- 6 S1 bar spacing and A_s provided are presented for fully developed bars.
Loads are based on vehicle impact only. For deck overhang design, the designer must incorporate dead load as well as check other limit states per LRFD A13.4.1.
 $f_y = 60$ ksi; $f'_c = 4$ ksi

10.3 At Grade Concrete Barriers

10.3.1 Differential Grade Concrete Barriers

The top of the differential grade concrete barrier shall have a minimum width of 6". If a luminaire or sign is to be mounted on top of the differential grade concrete barrier, then the width shall be increased to accommodate the mounting plate and 6" of clear distance on each side of the luminaire or sign pole. The transition flare rate shall follow the [Design Manual](#).

Differential grade concrete barriers are walls and barriers. All applicable limit states, design considerations, detailing, and constraints associated with walls and barriers shall apply. This includes, but is not limited to, provisions in AASHTO LRFD-BDS, the WSDOT GDM, and the WSDOT Design Manual for both walls and barriers.

Differential grade concrete barriers placed adjacent to a slope require implications of the slope to be incorporated into the design. The bench requirements for walls from the WSDOT GDM are applicable.

See [Section 10.2](#) for how elements are accepted for use within Washington State. Blunt edges, snags, and pinch points are not appropriate to expose to traffic.

10.3.1.A Differential Grade Concrete Barriers

Concrete barriers at grade are sometimes required in median areas with different roadway elevations on each side. The standard Single Slope barrier can be used for a grade difference up to 10" for a 2'-10" safety shape and up to 6" for a 3'-6" safety shape. See [Standard Plans C-70.10](#) and C-80.10 for details.

If the difference in grade elevations is 4'-0" or less, then the concrete barrier shall be designed as a rigid system in accordance with AASHTO LRFD with the following requirements:

1. All applicable loads shall be applied in accordance to AASHTO LRFD Section 3. The structural capacity of the differential grade concrete barrier and supporting elements shall be designed for the required Test Level (TL) vehicle impact design forces in accordance with AASHTO LRFD Sections 5 and 13. Any section along the differential grade barrier and supporting elements shall not fail in shear, bending, or torsion when the barrier is subjected to the TL impact forces.
2. For soil loads without vehicle impact loads, the concrete barrier shall be designed as a retaining wall (barrier weight resists overturning and sliding). Passive soil resistance may be considered with concurrence by the geotechnical engineer.
3. Vehicle impact loads shall be applied on the side of the concrete barrier retaining soil if there is traffic on both sides. The vehicle impact loads shall be applied at the height specified for intended Test Levels in accordance to the AASHTO LRFD Section 13, Table A13.2-1 "Design Forces for Traffic Railing (32-inch for TL-4, and 42-inch for TL-5)" as modified by [Section 10.2.4](#).

4. For soil loads with vehicle impact loads, the AASHTO LRFD-BDS Extreme Event loading for vehicular collision shall also be analyzed. Equivalent Static Load (ESL) per NCHRP Report 663 may be applied as the transverse vehicle impact load for evaluating sliding, bearing, and overturning only. For TL-3 barrier systems, the ESL shall be 10 kips, for TL-4 barrier systems, the ESL shall be 15 kips and for TL-5, the ESL shall be 23 kips. The point of rotation for overturning shall be taken at the toe of barrier. Sliding resistance factor shall be 0.8 and overturning resistance factor shall be 0.5 (supersedes AASHTO 10.5.5.3.3).
5. The effective length of the concrete barrier required for stability shall be no more than 10 times the overall height, but not to exceed the length between barrier expansion joints (or one precast section). The barrier shall act as a rigid body behavior and shall be continuous throughout this length of barrier. Any coupling between adjacent barrier sections or friction that may exist between free edges of barrier and the surrounding soil shall be neglected.
6. A special impact analysis shall be performed at the barrier ends if the barrier terminates without being connected to a rigid object or dowelled to another barrier. Differential barrier deflection from barrier impact may cause a vehicle to “snag” on the undeflected barrier. The barrier depth may need to be increased at the end to prevent this deflection.
7. The differential grade traffic barrier shall have dummy joints at 8 to 12 foot centers based on project requirements.
8. Full depth expansion joints with shear dowels at the top will be required at intervals based on analysis but not to exceed a 120'-0" maximum spacing.
9. Barrier bottom shall be embedded a minimum 6" below roadway. Roadway subgrade and ballast shall be extended below whole width of differential grade barrier. When a single slope barrier is used, or other configurations absent a footing, the depth of embedment shall be equal or greater than the grade separation.

Traffic barriers supporting a soil height greater than 4'-0" shall be designed as reinforced concrete retaining walls with a traffic barrier at the top and a barrier shape at the cut face. For external stability, the full loadings for the Extreme Event Limit State from AASHTO LRFD-BDS, Section 13 are applicable as modified by Section 10.2. When using these AASHTO loadings the associative phi factors from AASHTO are applicable. These provisions do not waive any requirements for walls or barriers from other codes, manuals, or sources.

10.3.2 Moment Slab Traffic Barrier

10.3.2.A General

The guidelines provided herein are based on NCHRP Report 663, FHWA/TX-12/9-1002-5, input from Texas Transportation Institute (TTI) on past WSDOT Standards, calculations, and engineering judgement. A resistance factor of 0.5 shall be used to determine rotational resistance. This guideline is applicable for TL-3, TL-4 and TL-5 barrier systems as defined in Section 13 of AASHTO LRFD-BDS. Moment Slab Traffic Barriers shall employ a current concrete traffic barrier from Section 10.2.3.

The options included in standard plan C81.15 are limited to cast-in-place slab applications.

Standard Plan C81.15 was developed for cast-in-place construction. Many of the details may also work for precast design. Other considerations such as weight revisions, shipping and picking considerations, super-elevation considerations, base friction variations, moment slab and/or barrier jointing details would need to be addressed by the Engineer of Record with stamped calculations and plans.

Figure 10.3.2-1 Global Stability of Barrier-Moment Slab System

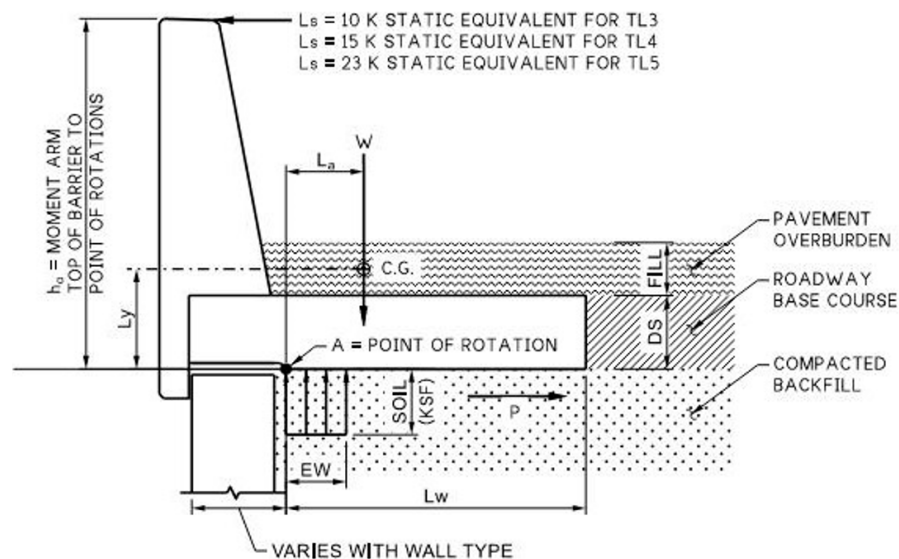

10.3.2.B Guidelines for Moment Slab Design

10.3.2.B.1 Structural Capacity

The structural capacity of the barrier and concrete moment slab shall be designed using impulse loads at appropriate Test Level applied to the top of the barrier, as shown in Figure 10.3.2-1 and in accordance with Sections 5 and 13 of AASHTO LRFD-BDS. For strength design the impact force, F_t , is applied at H_0 . Any section along the moment slab shall not fail in shear, bending, or torsion when the barrier is subjected to the design impact loads. The torsion capacity of the moment slab must be equal to or greater than the traffic barrier moment generated by the specified TL static equivalent of the vehicle impulse load.

The moment slab shall be designed as a deck supporting barrier in accordance to AASHTO LRFD-BDS A13.4.2 as modified by Section 10.2.4.A. The moment slab reinforcement shall be designed to resist combined forces from the moment M_S (kip-ft/ft) and the tensile force T (kip/ft). M_S and T are determined from the lesser of the

ultimate transverse resistance of barrier R_W (kip) and 120 percent of transverse vehicle impact force F_T (kip). M_S is not to be exceeded by the ultimate strength of barrier at its base M_C (kip-ft/ft).

10.3.2.B.2 Global Stability

Bearing stress, sliding, and overturning stability of the moment slab shall be based on an Equivalent Static Load (ESL) applied at the **top of the barrier as shown in figure 10.3.2-1**. For TL-3 barrier systems, the ESL shall be 10 kips. **For TL-4 barrier systems, the ESL shall be 15 kips.** For TL-5 barrier systems, the ESL shall be 23 kips.

The Equivalent Static Load (ESL) is assumed to distribute over the length of continuous moment slab through rigid body behavior. Barrier shall also be continuous or have shear connections between barrier sections if precast throughout this length of moment slab. Any coupling between adjacent moment slabs or friction that may exist between free edges of the moment slab and the surrounding soil **shall** be neglected.

10.3.2.B.3 Minimum and Maximum Dimensions

The minimum height of the traffic barrier portion of the moment slab shall be 42 inches above the finished roadway surface.

Moment slabs shall have a minimum width of 4.0 feet measured from the point of rotation to the heel of the slab and a minimum average depth of 0.83 feet. Moment slabs meeting these minimum requirements are assumed to provide rigid body behavior up to a length of 60 feet limited to the length between moment slab joints.

Rigid body behavior may be increased from 60 feet to a maximum of 120 feet if the torsional rigidity constant of the moment slab is proportionately increased and the reinforcing steel is designed to resist combined shear, moment, and torsion from TL static equivalent of the vehicle impulse loads.

For example: Rigid Body Length = $(J/J60) \times (60 \text{ ft.}) < 120 \text{ feet}$

The torsional rigidity constant for moment slabs shall be based on a solid rectangle using the following formula:

$$J = a \cdot b^3 \left[\frac{16}{3} - 3.36 \left(\frac{b}{a} \right) \left(1 - \frac{b^4}{12a^4} \right) \right]$$

Where:

2a = total width of moment slab

2b = average depth of moment slab

For example:

Minimum Moment Slab Width = 48 inches: a = 24 inches

Minimum Moment Slab Average Depth = 10 inches: b = 5 inches $J = J60 = 13,900 \text{ in}^4$

10.3.2.B.4 Sliding of the Barrier

The factored static resistance to sliding (ϕP) of the barrier-moment slab system along its base shall satisfy the following condition:

$$\phi P \geq \gamma L_s \quad (1)$$

Where:

- L_s = Equivalent Static Load (10 kips for TL-3, 15 kips for TL-4, and 23 kips for TL-5)
- ϕ = resistance factor (0.8) Supersedes AASHTO 10.5.5.3.3—Other Extreme Limit States
- γ = load factor (1.0) for TL-3 and TL-4 [crash tested extreme event] load factor (1.2) for TL-5 [untested extreme event]
- P = static resistance (kips)

P shall be calculated as: (2)

$$P = W \tan \phi_r$$

Where:

- W = weight of the monolithic section of barrier and moment slab between joints or assumed length of rigid body behavior whichever is less, plus any material laying on top of the moment slab
- ϕ_r = friction angle of the soil on the moment slab interface (°)

If the soil-moment slab interface is rough (e.g., cast in place), ϕ_r is equal to the friction angle of the soil ϕ_s . If the soil-moment slab interface is smooth (e.g., precast), $\tan \phi_r$ shall be reduced accordingly ($0.8 \tan \phi_s$).

10.3.2.B.5 **Overtipping of the Barrier**

The factored static moment resistance (ϕM) of the barrier-moment slab system to overturning shall satisfy the following condition:

$$\phi M \geq \gamma L_s h_a \quad (3)$$

Where:

- A = point of rotation, where the toe of the moment slab makes contact with compacted backfill adjacent to the fascia wall, or end of slab neglecting barrier tail for on grade applications.
- L_w = width of moment slab
- L_s = Equivalent Static Load (10 kips for TL-3, 15 kips for TL-4, and 23 kips for TL-5)
- ϕ = resistance factor (0.5) Supersedes AASHTO 10.5.5.3.3—Other Extreme Limit States and NCHRP Report 663
- γ = load factor (1.0) for TL-3 and TL-4 [crash tested extreme event] load factor (1.2) for TL-5 [untested extreme event]
- h_a = moment arm taken as the vertical distance from the point of impact due to the dynamic force (top of the barrier) to the point of rotation A
- M = static moment resistance (kips-ft)
M shall be calculated as:
$$M = W (L_a) \quad (4)$$
- W = weight of the monolithic section of barrier and moment slab between joints or assumed length of rigid body behavior whichever is less, plus any material laying on top of the moment slab
- L_a = horizontal distance from the center of gravity of the weight W to point of rotation A

The moment contribution due to any coupling between adjacent moment slabs, shear strength of the overburden soil, or friction which may exist between the backside of the moment slab and the surrounding soil shall be neglected.

10.3.2.C Guidelines for the Soil Reinforcement

Design of the soil reinforcement shall be in accordance with the [Geotechnical Design Manual Chapter 15](#).

10.3.2.D Design of the Wall Panel

The wall panels shall be designed to resist the dynamic pressure distributions as defined in the [Geotechnical Design Manual Chapter 15](#).

The wall panel shall have sufficient structural capacity to resist the maximum design rupture load for the wall reinforcement designed in accordance with the [Geotechnical Design Manual Chapter 15](#).

The static load is not included because it is not located at the panel connection.

10.3.3 Precast Concrete Barrier

10.3.3.A Concrete Barrier Type F and Type 2

“Concrete Barrier Type F” (see Standard Plans C-60.10 or C-60.15) may be used on bridges for median applications or for temporary traffic control based on the following guidelines:

1. The use of this barrier is limited to TL-3 conditions based upon the height not being sufficient to contain the test vehicle for TL-4 conditions.
2. For temporary applications, no anchorage is required if there is 3 feet or greater slide distance between the back of the traffic barrier and an object and 3 feet or greater to the edge of the bridge deck or a severe drop off (see [Design Manual](#)).
3. For permanent applications in the median, no anchorage will be required if there is a 6 foot or greater slide distance between the traffic barrier and the traffic lane.
4. For temporary applications, dual-sided barrier shall not be placed closer than 9 inches to the edge of a bridge deck or substantial drop-off and shall be anchored (see [Standard Plans K-80.35](#)).
5. When used to retain soil the provision of [Section 10.3.1.A](#) shall apply.
6. When transitioning to different height barrier off the structure roadside safety considerations shall be employed .

“Concrete Barrier Type 2” (see Standard Plan K-80.32) may be used on bridges for temporary traffic control or for partial replacements when matching existing barrier based on the following guidelines:

1. No anchorage is required if there is 3 feet or greater slide distance between the back of the traffic barrier and an object and 3 feet or greater to the edge of the bridge deck or a severe drop off (see [Design Manual](#)).
2. For temporary applications, the dual-sided barrier shall not be placed closer than 9 inches to the edge of a bridge deck or substantial drop-off and shall be anchored (see [Standard Plan K-80.35](#)).
3. When used to retain soil the provisions of [Section 10.3.1.A](#) shall apply.

10.3.3.B Concrete Barrier Type F Narrow Base and Concrete Barrier Type 4

“Concrete Barrier Type F Narrow Base” (see the Standard Plan C-60.10), is not a free standing traffic barrier. This barrier shall be placed against a rigid vertical surface that is at least as tall as the traffic barrier. For temporary use this barrier may be anchored to the bridge deck. (Standard Plan K-80.37). The barrier shall not be placed closer than 6-inches to the edge of the bridge deck or a severe drop-off. The “Concrete Barrier Type F Narrow Base” is not designed for soil retention.

“Concrete Barrier Type 4” (see the Standard Plan K-80.34), is not a free standing traffic barrier and is only suitable in temporary conditions. This barrier shall be placed against a rigid vertical surface that is at least as tall as the traffic barrier. The barrier shall not be placed closer than 6-inches to the edge of the bridge deck or a severe drop-off. The “Concrete Barrier Type 4” is not designed for soil retention.

10.3.4 **Miscellaneous Items**

Standard concrete barrier (see Standard Plans C70.10 & C80.10) and Differential Grade Concrete barriers are limited to median use when placed directly on a Structure and require roadway or base course material for a minimum of 2-feet vertical measured from lower roadway surface in other applications. See *WSDOT Design Manual Chapter 1610* for additional placement and use criteria for standard concrete barrier.

For walls placed behind Differential Grade Concrete barriers, Moment Slab Traffic Barrier, and standard concrete barrier, provide a minimum distance of 5-feet of widening with a 20:1 or flatter slope from the back of barrier to the inner face of wall.

For design of walls (except for MSE walls) which are not integral with the barrier and are placed behind Differential Grade Concrete barriers, Moment Slab Traffic Barrier, and standard concrete barrier, the minimum horizontal vehicular collision load (CT) for extreme event limit state shall be the Equivalent Static Load, ESL (10 kips for TL-3, 15 kips for TL-4, and 23 kips for TL-5).

10.4 Bridge Traffic Barrier Rehabilitation

10.4.1 Policy

The bridge traffic barrier retrofit policy is: “to systematically improve or replace existing deficient rails within the limits of roadway resurfacing projects.” This is accomplished by:

- Utilizing an approved crash tested rail system that is appropriate for the site or
- Designing a traffic barrier system to the strength requirements set forth by Section 2 of AASHTO *Standard Specifications for Highway Bridges, 17th edition*.
- **This section is applicable to modifications of structures and structural components in the barrier load path associated with barrier retrofit, rehabilitation, modification, repair, and/or replacements other than complete replacements for structures within the applicable timeframe, those constructed prior to the year 2000.**

10.4.2 Guidelines

A strength and geometric review is required for all bridge rail rehabilitation projects. If the strength of the existing bridge rail is unable to resist a 10 kip barrier impact design load or has not been crash tested, then modifications or replacement will be required to improve its redirection characteristics and strength. Bridges that have deficient bridge traffic barriers were designed to older codes.

The AASHTO LFD load of 10 kips shall be used in the retrofit of existing bridge traffic barrier systems constructed prior to the year 2000. No load less than 10 kips shall be applied, and the strength of the system shall be assessed in the pre and post retrofit condition. Any reduction in structural capacity of greater than or equal to 10% requires approval by the Design Unit Manager, or for designs done outside of the bridge office, approval by the State Bridge Design Engineer.

The use of the AASHTO LRFD criteria to design bridge traffic barrier rehabs will result in a bridge deck that has insufficient reinforcement to resist moment from a traffic barrier impact load and will increase the retrofit cost due to expensive deck modifications.

If the design of the bridge rehabilitation includes other bridge components that will be designed using AASHTO LRFD then the following minimum equivalent Extreme Event (CT) traffic barrier loading can be used limited to a maximum of <10% reduction:

$$\text{Flexure} = (1.3) * (1.67) * (10 \text{ kip}) / (0.9) = 24.10 \text{ kip}$$

$$\text{Shear} = (1.3) * (1.67) * (10 \text{ kip}) / (0.85) = 25.54 \text{ kip}$$

10.4.3 Design Criteria

Standard three beam guardrail post spacing is 6'-3" except for the SL-1 Weak Post, which is at 8'-4". Post spacing can be increased up to 10'-0" if the three beam guardrail is nested (doubled up).

Gaps in the guardrail are not allowed because they produce snagging hazards. The exceptions to this are:

- Movable bridges at the expansion joints of the movable sections.
- At traffic gates and drop down net barriers.
- At stairways.

Design F guardrail end sections will be used at the approach and trailing end of these gaps.

For Bridge Traffic Barrier Rehabilitation the following information will be needed from the Region Design office:

- Bridge Site Data Rehabilitation Sheet – DOT Form 235-002A.
- Photos, preferably digital JPEG format.
- Layout with existing dimensions.
- Standard Plan thrie beam guardrail transitions (selected by Region Design office) to be used at each corner of the bridge (contact bridges and structures office for thrie beam height).
- Location of any existing utilities.
- Measurements of existing ACP to top of curb at the four corners, midpoints and the locations of minimum and maximum difference (five locations each side as a minimum).
- Diagram of the location of Type 3 anchors, if present, including a plan view with vertical and horizontal dimensions of the location of the Type 3 anchor connection relative to the intersecting point of the back of pavement seat with the curb line.
- The proposed overlay type, quantities of removal and placement.
- For timber bridges, the field measurement of the distance from the edge of bridge deck to the first and second stringer is required for mounting plate design.

Placement of the retrofit system will be determined from the [Design Manual](#). Exceptions to this are bridges with sidewalk strength problems, pedestrian access issues, or vehicle snagging problems.

10.4.4 WSDOT Bridge Inventory of Bridge Rails

Concrete balusters are deficient for current lateral load capacity requirements. They have approximately 3 kips of capacity whereas 10 kips is required.

The curb and rail base system/Type 7 bridge rail shall maintain a minimum 6 inch curb height. If this requirement is not met then the existing HMA will need to be removed to re-establish the 6 inch minimum curb height during the next paving cycle.

Figure 10.4.4-1

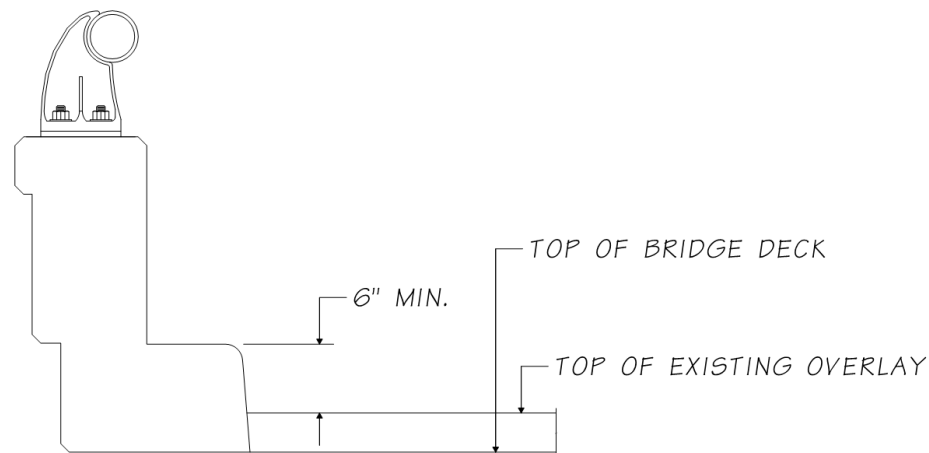

The combination high-base concrete parapet and metal rail may or may not be considered adequate depending upon the rail type. The metal rail Type R, S, and SB attached to the top of the high-base parapet are considered capable of resisting the required 5 kips of lateral load. Types 3, 1B, and 3A are considered inadequate. See the [Design Manual](#) for replacement criteria.

10.4.5 Available Retrofit Designs

10.4.5.A Washington Thrie Beam Retrofit of Concrete Balusters

This system consists of thrie beam guardrail stiffening of existing concrete baluster rails with timber blockouts. The Southwest Research Institute conducted full-scale crash tests of this retrofit in 1987. Results of the tests were satisfactory and complied with criteria for a Test Level 2 (TL-2) category in the Guide Specifications. For complete details see [Bridge Standard Drawing 10.4-A1-1](#).

10.4.5.B Delaware Thrie Beam Guardrail

This crash tested rail system can be utilized at the top of a raised concrete sidewalk to separate pedestrian traffic from the vehicular traffic or can be mounted directly to the top of the concrete deck. For complete details see Thrie Beam Retrofit Concrete Curb in Appendix 10.4-A1-3.

10.4.5.C Concrete Parapet Retrofit

This is similar to the Delaware system. For complete details see Appendix 10.4-A1-2.

10.4.5.D SL-1 Weak Post

This bridge traffic barrier is a crash tested weak post rail system. It was developed by Southwest Research Institute and reported in NCHRP Report 239 for low-volume rural roadways with little accident history. This design has been utilized on a number of short concrete spans and timber bridges. A failure mechanism is built into this rail system such that upon a 10 kip applied impact load, the post will break away from the mounting bracket. The thrie beam guardrail will contain the vehicle by virtue of its ribbon strength. This system was designed for a Working Stress design force of 10 kip applied at 22 inches above the deck surface. To ensure minimal or no damage to the bridge deck and stringers, the breakaway connection may be modified for a lower impact load (2 kip minimum) with approval of the WSDOT State Bridge Design Engineer. The 2 kip minimum equivalent impact load is based on evaluation of the wood rail post strength tested in NCHRP Report 239. The appropriate guardrail approach transition shall be a Case 14 placement as shown on WSDOT Standard Plan C-2h. For complete details see Appendix 10.4-A1-4.

10.4.6 Available Replacement Designs

10.4.6.A Traffic Barrier – Shape F Retrofit

This is WSDOT's preferred replacement of deficient traffic barriers and parapets on high volume highways with a large truck percentage. All interstate highway bridges shall use this type of barrier unless special conditions apply. For complete details see Bridge Standard Drawing 10.4-A2.

10.5 Bridge Railing

10.5.1 Design

WSDOT pedestrian and bicycle/pedestrian railings are designed in accordance with Chapter 13 in AASHTO LRFD. AASHTO LRFD calls for a minimum of 42" for bicycle railings whereas WSDOT requires a minimum height of 54" on structures. The railings in [Section 10.5.2](#) are not designed for vehicular impact loads assuming location is low speed, location is outside of Design Clear Zone as defined in the *Design Manual* Chapter 1600, or location has minimal safety consequence from collapse of railing. Railings for other locations shall be designed for vehicular impact loads in accordance with Chapter 13 and/or 15 in the AASHTO LRFD. Emergency and maintenance access shall be considered.

Pedestrian and bicycle railings shall be designed using a Live Load factor of 1.75.

Fall Protection railing shall meet the requirements of [WAC 296-880](#) and as described in the *Design Manual* [Chapter 1060](#).

Fall protection pipe railings shall be designed using a Live Load factor of 1.75.

Cable fence shall be designed to Allowable Stress Design

Baluster spacing shall be in accordance with AASHTO LRFD Chapter 13.8. The use of a more restrictive baluster spacing, such as IBC 1013.4, may be acceptable on a case-by-case basis. Request to use a more restrictive baluster spacing shall come from the WSDOT Project Engineer and shall be approved by the WSDOT State Bridge Design Engineer.

10.5.2 Railing Types

10.5.2.A Bridge Pedestrian Railing Type BP-10

This pedestrian railing is designed to sit on top of the 32" and 34" traffic barriers and to meet pedestrian and fall protection height requirements of 42". For complete details see Bridge Standard Drawings [10.5-A1-1](#) and [2](#).

10.5.2.B Bridge Pedestrian Railing Type BP-22

These railings are designed to meet WSDOT's minimum bicycle height requirements of 54", and sit on top of the 32" and 34" traffic barriers.

There are two versions—the BP and S-BP. The BP is the standard railing and is made out of aluminum. The S-BP is the steel version designed for use in rural areas because of aluminum theft. For complete details see Bridge Standard Drawings [10.5-A2-1](#) and [2](#) for Aluminum and [10.5-A3-1](#) and [2](#) for Steel.

10.5.2.C Bridge Pedestrian Railing Type BP-12

These railings are designed to meet WSDOT's minimum bicycle height requirements of 54", and sit on top of the 42" traffic barriers. For complete details see Bridge Standard Drawings [10.5-A6-1](#) and [2](#) for Aluminum and [10.5-A7-1](#) and [2](#) for Steel.

10.5.2.D Bridge Pedestrian Railing Type BP-54

This railing is designed to sit on top of a six-inch curb on the exterior of a bridge sidewalk. It meets the bicycle height requirements of 54". For complete details see Standard Drawings [10.5-A4-1](#) and [2](#).

10.5.2.E Bridge Railing Type Snow Fence

This railing is designed to prevent large chunks of plowed snow from falling off the bridge on to traffic below. For complete details see Standard Drawings [10.5-A5-2](#) and [10.5-A5-3](#).

10.5.2.F Bridge Railing Type Chain Link Fence

This railing is designed to minimize the amount of objects falling off the bridge on to traffic below. The design loading shall include pedestrian loads and wind loads as specified in AASHTO LRFD. Consult with the HQ Design Office Railroad Liaison regarding review and acceptance of this detail near railroads. For complete details see Standard Drawing [10.5-A5-4](#).

10.6 Bridge Approach Slabs

Bridge approaches typically experience two types of settlement, global and local. Global settlement is consolidation of the deeper natural foundation soils. Local settlement is mainly compression of fill materials directly beneath the approach pavement due to construction. The combination of global and local settlements adjacent to the bridge end piers form the characteristic “bump” in the pavement at the bridge. The approach slab significantly reduces local settlement and will provide a transition to the long term roadway differential settlements. Generally, abutments with a deep foundation will have greater differential roadway settlements than spread footing foundations.

When Are Bridge Approach Slabs Required

Bridge approach slabs are required for the following structures:

- New bridges
- Widened bridges (full roadway width)
- Class 1 and Class 2 Buried Structures without a full depth Roadway section (including HMA and CSBC) within 25 feet of each end of the Buried Structure

Bridge approach slabs may be omitted for Buried Structures with Structural Clear Spans up to 30 ft when concurrence is reached between the Geotechnical Office, the Region Design Project Engineer Office, and the Bridge and Structures Office. Allowances for deleting bridge approach slabs are described in [GDM Section 8.6.5.3](#).

Bridge approach slab lengths may be reduced for Buried Structures with Structural Clear Spans up to 25 ft with approval from the State Geotechnical Engineer. The reduced bridge approach slab length shall not be less than the greater of the structural span length of the Buried Structure and 10 ft.

Precast bridge approach slabs shall be considered when accelerated construction is required. Modifications may be required to the basecourse to provide a smooth surface for the precast unit(s).

Standard Plan A-40.50 – The Standard Plan A-40.50 is available to use or reference in a contract. Bridge and Structures Office designs will provide **geometric** information in a customized approach slab Plan View and show the approach slab length on the Bridge Layout Sheet.

Bridge Runoff – Bridge runoff at the abutments shall be carried off and collected at least 10 feet beyond the bridge approach slab. Drainage structures such as grate inlets and catch basins shall be located in accordance with [Standard Plan B-95.40](#) and the recommendations of the Hydraulics Branch.

Approach Pay Item –All costs in connection with constructing bridge approach slabs are included in the unit contract price per square yard for “Bridge Approach Slab.” The pay item includes steel reinforcing bars, approach slab anchors, concrete, and compression seals.

10.6.1 Notes to Region for Preliminary Plan

All bridge preliminary plans shall show approach slabs at the ends of the bridges. In the Notes to Region in the first submittal of the Preliminary Plan to the Region, the designer shall ask the following questions:

1. Bridge approach slabs are shown for this bridge, and will be included in the Bridge PS&E. Do you concur?
2. The approach ends of the bridge approach slabs are shown normal to the survey line (a) with or (b) without steps (the designer shall propose one alternative). Do you concur?
3. Please indicate the pavement type for the approach roadway.

Depending on the type and number of other roadway features present at the bridge site (such as approach curbs and barriers, drainage structures, sidewalks, utilities and conduit pipes) or special construction requirements such as staged construction, other questions in the Notes to Region pertaining to the bridge approach slabs may be appropriate.

Special staging conditions exist when the abutment skew is greater than 30° and for wide roadway widths. This includes bridge widenings with (or without) existing bridge approach slabs. The preliminary plan should include details showing how these conditions are being addressed for the bridge approach slabs, and the designer shall include appropriate questions in the Notes to Region asking for concurrence with the proposed design.

10.6.2 Bridge Approach Slab Design Criteria

The standard bridge approach slab design is based on the following criteria:

1. The bridge approach slab is designed as a slab in accordance with AASHTO LRFD. (Strength Limit State, IM = 1.33, no skew).
2. The support at the roadway end is assumed to be a uniform soil reaction with a bearing length that is approximately $\frac{1}{3}$ the length of the approach slab, or $25'/3 = 8'$.
3. The Effective Span Length (S_{eff}), regardless of approach length, is assumed to be: $25' \text{ approach} - 8' = 17'$.
4. Longitudinal reinforcing bars do not require modification for skewed approaches up to 30 degrees or for slab lengths greater than 25'.
5. The approach slab is designed with a 2" concrete cover to the bottom reinforcing.

10.6.3 Bridge Approach Slab Detailing

The bridge approach slab and length along center line of project shall be shown in the Plan View of the Bridge Layout sheet. The Bridge Plans will also include approach slab **geometric** information as shown in **the Plan view of** Bridge Standard Drawing 10.6-A1-1. A minimum pavement seat width of 10 inches is required to support the bridge end of the bridge approach slab. The Approach Slab Plan sheets should be modified as appropriate to match the bridge site conditions. Approach slab Plan Views shall be customized for the specific project and all irrelevant details shall be removed.

Plan View dimensions shall define the plan area of the approach slab. The minimum dimension from the bridge is 25'. If there are skewed ends, then dimensions shall be provided for each side of the slab, or a skew angle and one side, in addition to the width. For slabs on a curve, the length along the project line and the width shall be shown.

Longitudinal contraction joints are required on bridge approach slabs wider than 40 ft. or where steps are used on skewed alignments. Joints shall be located at lane lines or median barrier and in accordance with Bridge Standard Drawing **10.6-A1-2**. If joints are to be sawcut, cutting shall occur as soon as possible after finishing the concrete, but after the concrete has set enough not to be torn or damaged by the blade. Additionally, cutting shall occur before shrinkage cracks start to appear, but no later than 48 hours after concrete placement. Early-entry sawing equipment is typically used within 4 hours after finishing the slab, and conventional sawing equipment is typically used between 4 and 12 hours, but may vary depending on the concrete mix design and environmental conditions.

Additional layout and details may be required to address special roadway features and construction requirements such as: roadway curbs and barriers, sidewalks, utilities and conduits and staging. This means, if sidewalks and interior barriers (such as traffic-pedestrian barriers) are present, special details will be required in the Bridge Plans to show how the sidewalks and interior barriers are connected to and constructed upon the bridge approach slab. If the bridge construction is staged, then the approach slabs will also require staged construction.

10.6.4 Skewed Bridge Approach Slabs

For all skewed abutments, the roadway end of the bridge approach slab shall be normal to the roadway centerline. The WSDOT State Bridge Design Engineer shall be consulted when approach slab skew is greater than 30 degrees. Skews greater than 20 degrees require analysis to verify the bottom mat reinforcement, and may require expansion joint modifications.

The roadway end of the approach may be stepped to reduce the size or to accommodate staging construction widths. **The approach slab shall only be stepped** if the approach slab area can be reduced by 50 SY or more. At no point shall the roadway end of the approach slab be closer than 25' to the bridge. These criteria apply to both new and existing bridge approach slabs. If stepped, the design shall provide the absolute minimum number of steps and the longitudinal construction joint shall be located on a lane line. See Figure 10.6.4-1 for clarification.

Figure 10.6.4-1 Skewed Approach

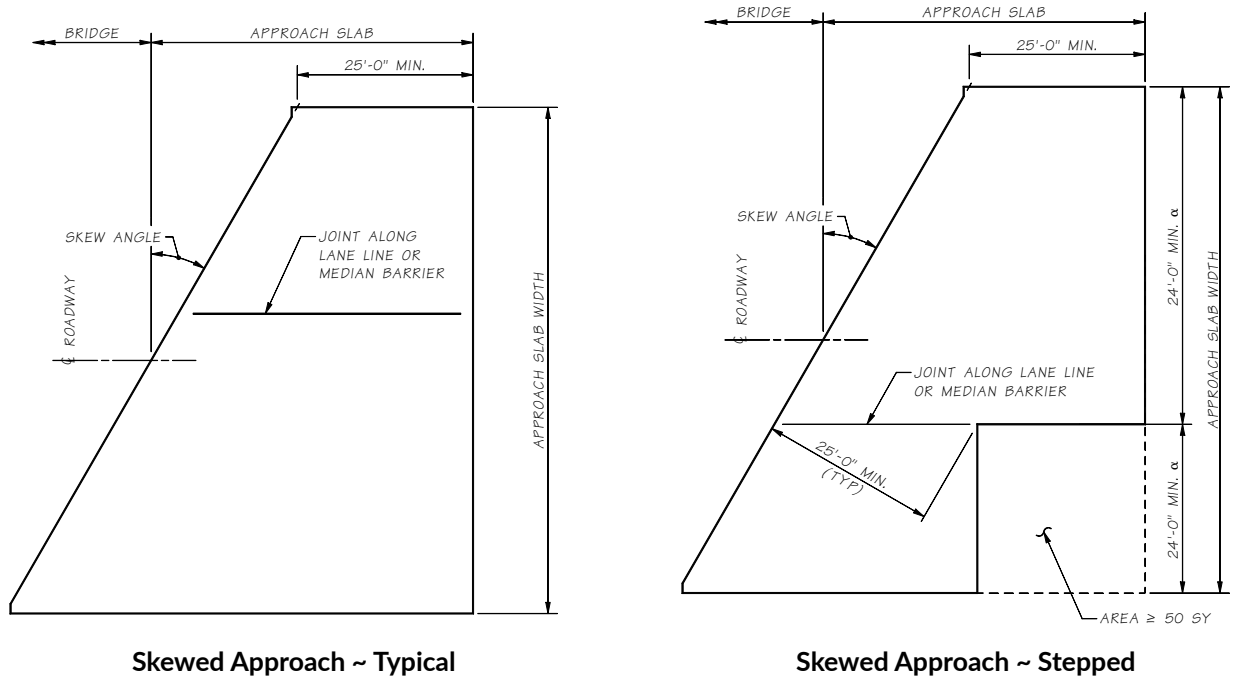

Skewed Approach ~ Typical

Skewed Approach ~ Stepped

α - DIMENSION MAY BE TWO LANE WIDTHS OR ONE LANE WIDTH PLUS THE SHOULDER WIDTH IF THE SHOULDER \geq 8'-0".

In addition, for bridges with traffic barriers and skews greater than 20 degrees, the AP8 bars shall be rotated in the acute corners of the bridge approach slabs. Typical placement is shown in the flared corner steel detail, Figure 10.6.4-2.

Figure 10.6.4-2 Flared Corner Steel

ROTATE AP8 BARS IN ACUTE CORNERS OF APPROACH SLAB.

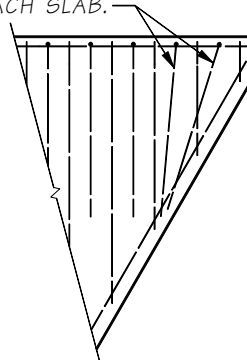

10.6.5 Approach Anchors and Expansion Joints

For semi-integral abutments or stub abutments, the joint design shall be checked to ensure the available movement of the standard joint is not exceeded. In general, the approach slab is assumed to be stationary and the joint gap is designed to vary with the bridge movement. Approach Slab Sheets 10-A1-3 and Standard Plan A-40.50 detail a typical 2½" compression seal. For approach slabs with barrier, the compression seal shall extend into the barrier.

Approach slab anchors installed at bridge abutments shall be as shown in the Bridge Plans. For bridges with semi-integral type abutments, this can be accomplished by showing the approach slab anchors in the End Diaphragm or Pavement Seat details.

L Type Abutments – L type abutments do not require expansion joints or approach anchors because the abutment and bridge approach slab are both considered stationary. A pinned connection is preferred. The L type abutment anchor detail, as shown sign in Figure 10.6.5-1, shall be added to the abutment plan sheets. The pinned anchor for bridges with L type abutments shall be a #5 bar at one foot spacing, bent as shown, with 1'-0" embedment into both the pier and the bridge approach slab. This bar shall be included in the bar list for the bridge substructure.

Figure 10.6.5-1 L Type Abutment Anchor Detail

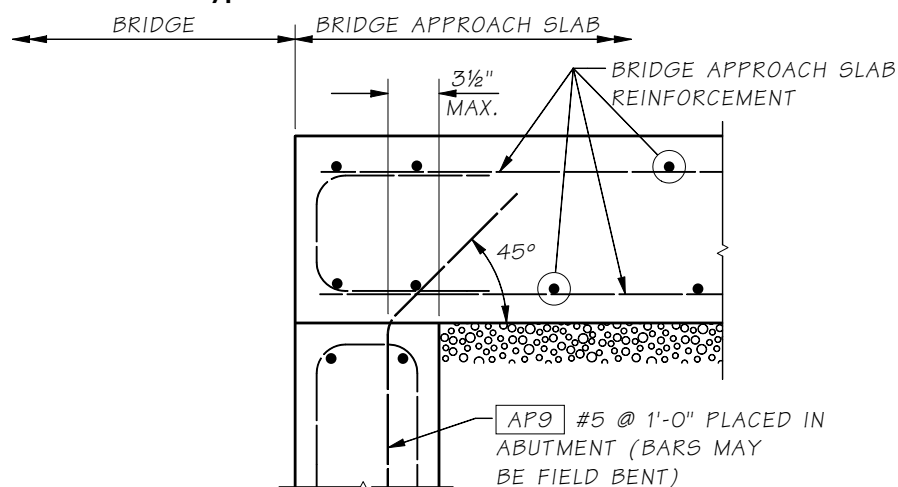

10.6.6 Bridge Approach Slab Addition or Retrofit to Existing Bridges

When bridge approach slabs are to be added or replaced on existing bridges, modification may be required to the pavement seats. Either the new bridge approach slab will be pinned to the existing pavement seat, or attached with approach anchors with a widened pavement seat. Pinning is a beneficial option when applicable as it reduces the construction cost and time.

The pinning option is only allowed on semi-integral abutments as a bridge approach slab addition or retrofit to an existing bridge. Figure 10.6.6-1 shows the pinning detail. As this detail eliminates the expansion joint between the bridge approach slab and the bridge, the maximum bridge superstructure length is limited to 150'. The WSDOT State Bridge Design Engineer may modify this requirement on a case by case basis. Additionally, if the roadway end of the bridge approach slab is adjacent to PCCP roadway, then the detail shown in Figure 10.6.6-2 applies. PCCP does not allow for as much movement as HMA and a joint is required to reduce the possibility of buckling.

When pinning is not applicable, then the bridge approach slab shall be attached to the bridge with approach anchors. If the existing pavement seat is less than 10 inches, the seat shall be modified to provide at least 10 inches of seat width. The WSDOT State Bridge Design Engineer may modify this requirement on a site-specific basis. Generic pavement seat repair details are shown in Appendix 10.6-A2-1 for a concrete repair and Appendix 10.6-A2-2 for a steel T-section repair. These sheets can be customized for the project and added to the Bridge Plans.

When a bridge approach slab is added to an existing bridge, the final grade of the bridge approach slab concrete shall match the existing grade of the concrete bridge deck, including bridges with asphalt pavement. The existing depth of asphalt on the bridge shall be shown in the Plans and an equal depth of asphalt placed on a new bridge approach slab. If the existing depth of asphalt is increased or decreased, the final grade shall also be shown on the Plans.

Figure 10.6.6-1 Pinned Approach Slab Detail

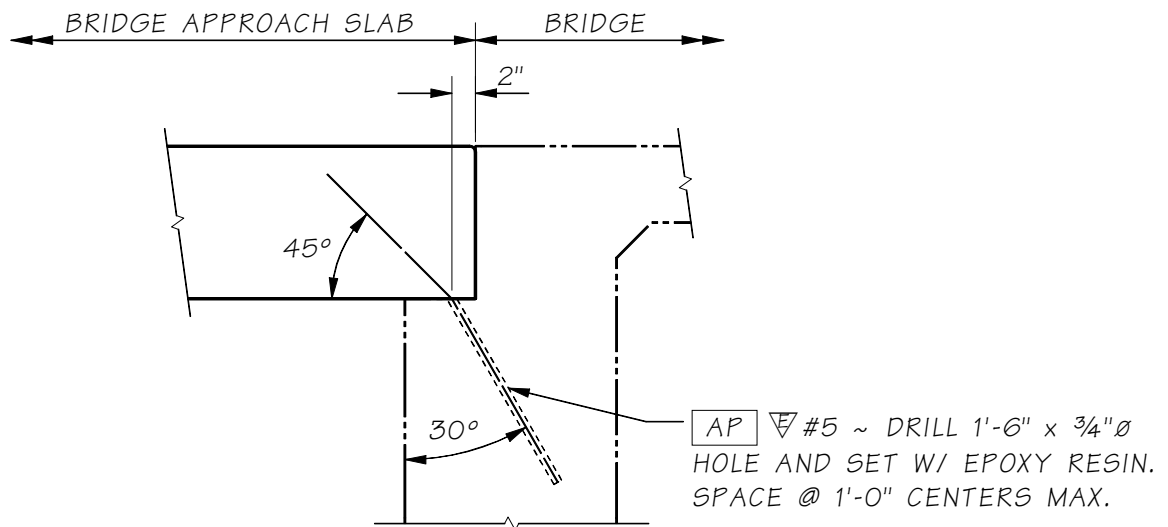
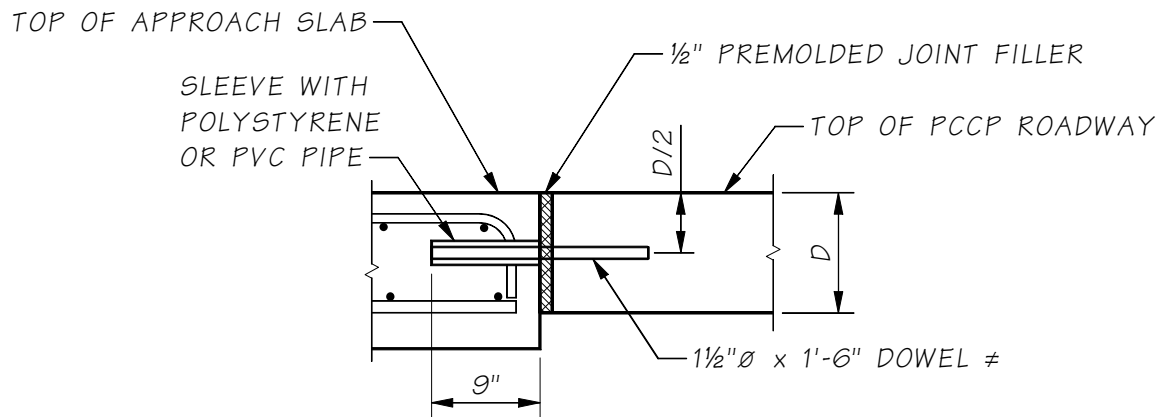

Figure 10.6.6-2 PCCP Roadway Dowel Bar Detail



INSERT DOWELS PARALLEL TO CENTER LINE ALONG TRANSVERSE CONSTRUCTION JOINT.

DRILL 1 3/4" Ø HOLE AND SET WITH EPOXY RESIN IF PLACED INTO EXISTING PCCP ROADWAY.

10.6.7 Bridge Approach Slab Staging

Staging plans will most likely be required when adding or retrofitting approach slabs on existing bridges. The staging plans shall be a part of the bridge plans and shall be on their own sheet. Coordination with the Region is required to ensure agreement between the bridge staging sheet and the Region traffic control sheet. The longitudinal construction joints required for staging shall be located on lane lines. As there may not be enough room to allow for a lap splice in the bottom transverse bars, a mechanical splice option shall be added. If a lap splice is not feasible, then only the mechanical splice option shall be given. See Figure 10.6.6-3.

Figure 10.6.6-3 Alternate Longitudinal Joint Detail

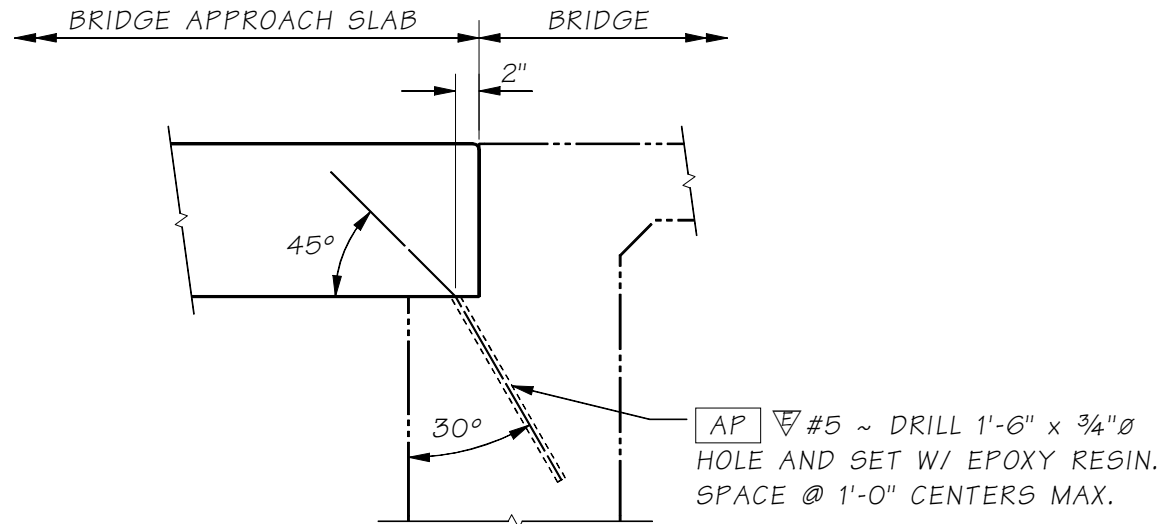

10.7 Traffic Barrier on Bridge Approach Slabs

Placing the traffic barrier on the bridge approach slab is beneficial for the following reasons.

- The bridge approach slab resists traffic impact loads and may reduce wing wall thickness
- Simplified construction and conduit placement
- Bridge runoff is diverted away from the abutment

Most bridges will have some long-term differential settlement between the approach roadway and the abutment. Therefore, a gap between the bridge approach slab and wing (or wall) shall be shown in the details. The minimum gap is twice the long-term settlement, or 2 inches as shown in [Figure 10.7-1](#). A 3 inch gap is also acceptable.

When the traffic barrier is placed on the bridge approach slab, the following barrier guidelines apply.

- Barrier shall extend to the end of the bridge approach slab
- Conduit deflection or expansion fittings shall be called out at the joints
- Junction box locations shall start and end in the approach
- The top transverse reinforcing in the slab shall be sufficient to resist a traffic barrier impact load. A 6'-0" (hooked) #6 epoxy coated bar shall be added to the approach slab as shown in [Figure 10.7-1](#).

Figure 10.7-1

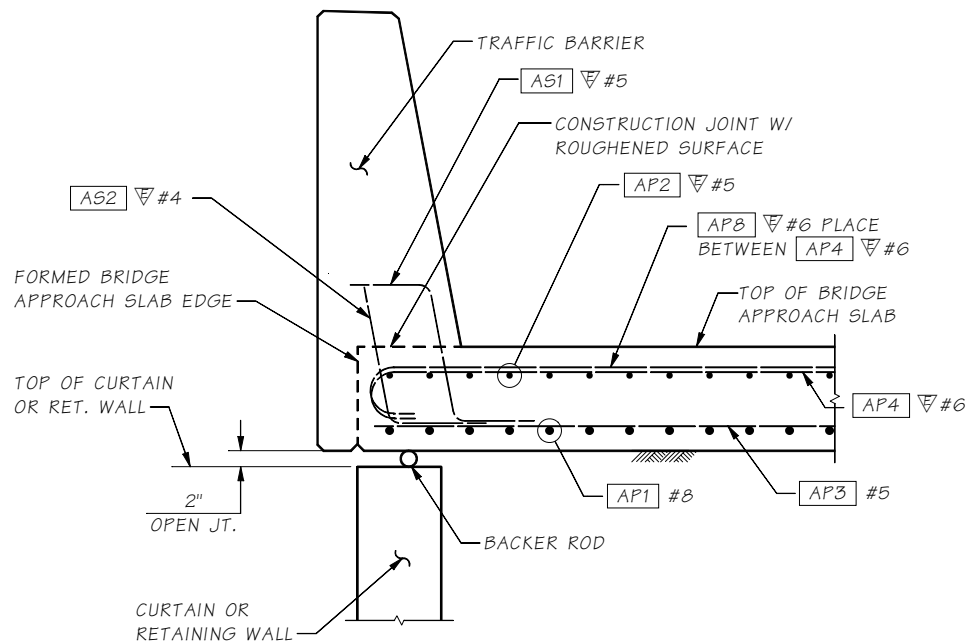

10.7.1 Bridge Approach Slab over Wing Walls, Cantilever Walls or Geosynthetic Walls

All walls that are cast-in-place below the bridge approach slab should continue the barrier soffit line to grade. This includes geosynthetic walls that have a cast-in-place fascia.

[Figure 10.7.1-1](#) shows a generic layout at an abutment. Note the sectional Gap Detail, [Figure 10.7-1](#) applies.

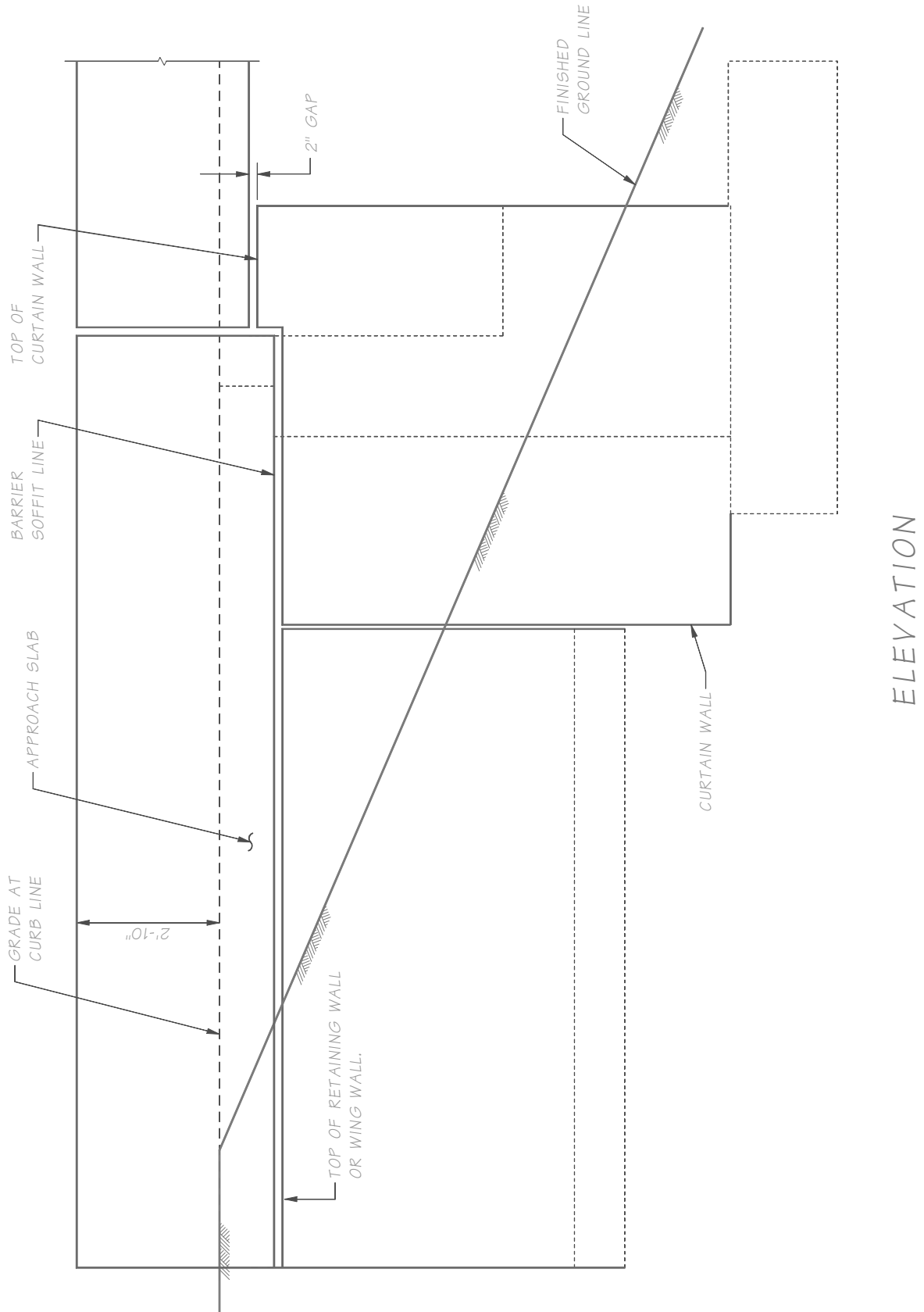

Figure 10.7.1-1

10.7.2 Bridge Approach Slab over SE Walls

The tops of structure earth (SE) walls are uneven and shall be covered with a fascia to provide a smooth soffit line. Usually SE walls extend well beyond the end of the approach slab and require a moment slab. Since SEW barrier is typically 5'-0" deep from the top of the barrier, the soffit of the SEW barrier and bridge barrier do not match. The transition point for the soffit line shall be at the bridge expansion joint as shown in Figure 10.7.2-2. This requires an extended back side of the barrier at the approach slab to cover the uneven top of the SE wall.

Battered wall systems, such as block walls, use a thickened section of the curtain wall to hide some of the batter. The State Bridge and Structures Architect will provide dimensions for this transition when required.

Figure 10.7.2-1

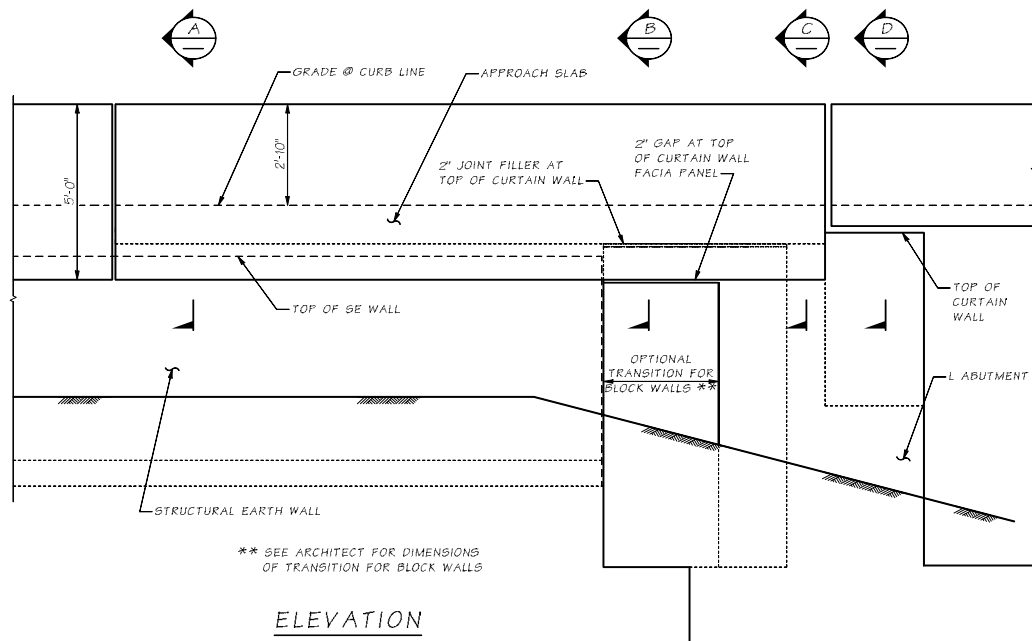
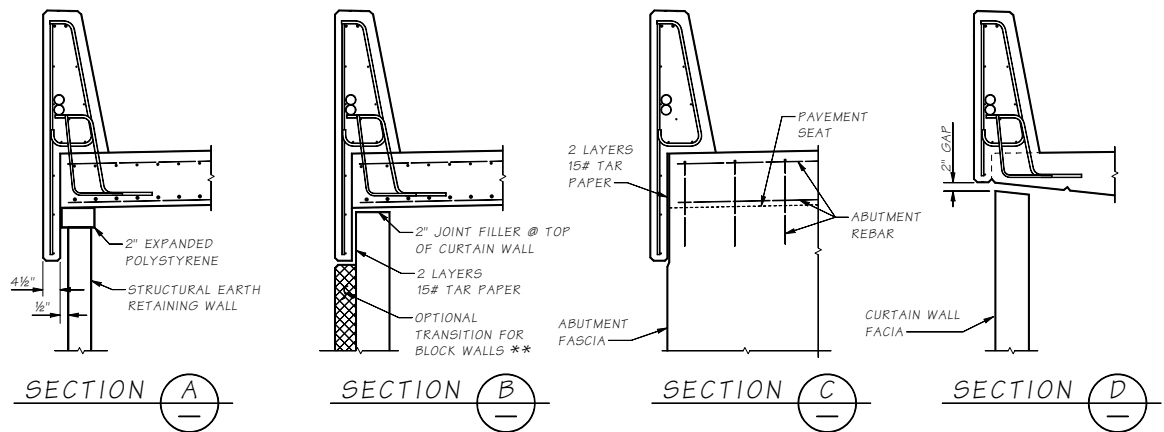

Figure 10.7.2-2



10.8 Utilities Installation on New and Existing Structures

10.8.1 General Concepts

The utilities included under this section are those described in *Standard Specifications* Section 6-01.10. The Bridge designer shall determine if the utility may be attached to the structure and the location. Bridge plans shall include all hardware specifications and details for the utility attachment as provided in any written correspondence with the utility and the utility agreement coordinated by the WSDOT Region Utility Engineer with the associated utility.

10.8.1.A Responsibilities of the Utility Company

The Region or utility company will initiate utility installations and provide design information. The utility company shall be responsible for calculating design stresses in the utility and design of the support system. Utility support design calculations with a State of Washington Professional Engineer stamp, signed and dated, shall be submitted to the Bridge and Structures Office for review. The following information shall be provided by the utility company and shown in the final Bridge Plans.

- Location of the utility outside the limits of the bridge structure
- Number of utilities, type, size, and weight (or Class) of utility lines
- Utility minimum bending radius for the conduit or pipeline specified

Utility General Notes and Design Criteria are stated in Form 224-047. See [Figure 10.8.1-1](#). This form outlines most of the general information required by the utility company to design their attachments. The Bridge Office will generally provide the design for lightweight hanger systems, such as electrical conduits, attached to new structures.

10.8.1.B Confined Spaces

A confined space is any place having a limited means of exit that is subject to the accumulation of toxic or flammable contaminants or an oxygen deficient environment. Confined spaces include but are not limited to pontoons, box girder bridges, storage tanks, ventilation or exhaust ducts, utility vaults, tunnels, pipelines, and open-topped spaces more than 4 feet in depth such as pits, tubes, vaults, and vessels.

10.8.1.C Coating and Corrosion Protection

When the bridge is to receive pigmented sealer, consideration shall be given to painting any exposed utility lines and hangers to match the bridge. When a pigmented sealer is not required, steel utility conduits and hangers shall be painted or galvanized for corrosion protection. The special provisions shall specify cleaning and painting procedures.

Figure 10.8.1-1 General Notes and Design Criteria for Utility Installations to Existing Bridges
WSDOT Form 224-047

 Washington State Department of Transportation	General Notes and Design Criteria for Utility Installations to Existing Bridges
General Notes	
<p>All materials and workmanship shall be in accordance with the requirements of the state of Washington, Department of Transportation, Standard Specifications for Road, Bridge, and Municipal Construction, current edition. The utility conduits shall be labeled in accordance with Section 6-01.10.</p>	
<p>All steel in utility supports, including fastenings and anchorages, shall be galvanized in accordance with AASHTO M-111 or M-232 (ASTM A-123 or A-153 respectively).</p>	
<p>All utilities and utility support surfaces, including any galvanized utilities, shall be painted in accordance with Standard Specifications Section 6-07. The final coat shall match the bridge color.</p>	
<p>Galvanized metal or aluminum utilities completely hidden from public view may be exempted from the above painting requirements.</p>	
<p>Any painted surfaces damaged during construction shall be cleaned and painted as noted above.</p>	
<p>Any paint splatters shall be removed from the bridge.</p>	
<p>Appearance of the utility installation shall be given serious consideration in all cases. Where possible, the utility installation shall be hidden from public view.</p>	
<p><i>The notes and criteria explained here are presented as a guide only. Each proposed utility installation shall be submitted to the Department of Transportation for approval on an individual basis. Compliance with these criteria does not assure approval, nor does variance from these criteria, for reasonable cause, necessarily exclude approval.</i></p>	
Design Criteria	
<p>1. Pipelines carrying volatile fluids through a bridge superstructure shall be designed by the utility company in accordance with WAC 480-93, Gas Companies - Safety, and Minimum Federal Safety Standard, Title 49 Code of Federal Regulations (CFR) Section part 192. WAC 468-34-210, Pipelines - Encasement, describes when casing is required for carrying volatile fluids across structures. Generally, casing is not required for pipelines conveying natural gas per the requirements of WAC 468-34-210. If casing is required, then WAC 468-34-210 and WAC 480-93-115 shall be followed.</p>	
<p>2. Utilities shall not be attached above the bridge deck nor attached to railing or rail posts.</p>	
<p>3. Utilities shall not extend below bottom of superstructure.</p>	
<p>4. The utilities shall be provided with suitable expansion devices near bridge expansion joints and/or other locations as required to prevent temperature and other longitudinal forces from being transferred to bridge members.</p>	
<p>5. Rigid conduit shall extend 10 feet (3 meters) minimum, beyond the end of the bridge abutment.</p>	
<p>6. Utility supports shall be designed such that neither the conduit, the supports, nor the bridge members are overstressed by any loads imposed by the utility installation.</p>	
<p>7. Utility locations and supports shall be designed so that a failure (rupture, etc.) will not result in damage to the bridge, the surrounding area, or be a hazard to traffic.</p>	
<p>8. Conduit shall be rigid.</p>	
<p>(Items 1 through 8 may be cross-referenced with Bridge Design Manual, Utilities Section.)</p>	
<p>9. Lag screws may be used for attaching brackets to wooden structures. All bolt holes shall meet the requirements of Sections 6-04.3(4) and 6-04.3(5) of the Washington State Department of Transportation Standard Specifications for Road, Bridge, and Municipal Construction, current edition.</p>	
DOT Form 224-047 Revised 05/2018	Exhibit " _____ " Permit/Franchise _____ Page _____ of _____

**Figure 10.8.1-1 General Notes and Design Criteria for Utility Installations to Existing Bridges
WSDOT Form 224-047 (continued)**

- 10. Welding across main members will not be permitted. All welding must be approved.
- 11. Utilities shall be located to minimize bridge maintenance and bridge inspection problems.
- 12. Attach conduits or brackets to the concrete superstructure with resin bond anchors. Lag screws shall not be used for attachment to concrete.
- 13. Drilling through reinforcing steel will not be permitted. If steel is hit when drilling, the anchorage location must be moved and the abandoned hole filled with nonshrink grout conforming to the requirements of Section 9-20.3(2) and placement shall be as required in Section 6-02.3(20) of the Washington State Department of Transportation Standard Specifications for Road, Bridge, and Municipal Construction, current edition .
- 14. There shall be a minimum of 3 inches (80 millimeters) edge distance to the center line of bolt holes in concrete.
- 15. All utilities and utility supports shall be designed not only to support their dead load but to resist other forces from the utility (surge, etc.) and wind and earthquake forces. The utility company may be asked to submit one set of calculations to verify their design forces.
- 16. Drilling into prestressed concrete members for utility attachments shall not be allowed.
- 17. Water or sewer lines to be placed lower than adjacent bridge footings shall be encased if failure can cause undermining of the footing.

DOT Form 224-047
Revised 05/2018

Exhibit " _____ " _____
Permit/Franchise _____
Page _____ of _____

10.8.2 Utility Design Criteria

All utilities shall be designed to resist Strength and Extreme Event Limits States. This includes and is not limited to dead load, expansion, surge, and earthquake forces. Designers shall review WSDOT [Form 224-047](#) “General Notes and Design Criteria for Utility Installations to Existing Bridges” and the items in this section when designing a utility system or providing a review for an existing bridge attachment. See [Figure 10.8.1-1](#) and [Section 10.9](#) Utility Review Procedure for Installation on Existing Bridges.

The Bridge Engineer shall review the utility design to ensure the utility support system will carry all transverse and vertical loading. Loading will include (and is not limited to): dead load, temperature expansion, dynamic action (water hammer), and seismic inertial load. Positive resistance to loads shall be provided in all directions perpendicular to and along the length of the utility as required by the utility engineer.

Where possible, dynamic fluid action loads shall be resisted off the bridge. If these loads must be resisted on the bridge, the utility engineer shall be involved in the design of these supports. The utility engineer shall determine these design forces being applied to the bridge. Realize these forces can be generated in any pipe supporting moving fluids, which may include, but are not limited to: water, sewer, storm water, and fire suppression systems.

Where utilities are insulated, the insulation system shall be designed to allow the intended motion range of the hardware supporting the utility. This will prevent unanticipated stresses from being added to the hanger in the event the insulation binds up the hardware.

10.8.2.A Utility Location

Utilities shall be located, such that a support failure will not result in damage to the bridge, the surrounding area, or be a hazard to traffic. In most cases, the utility shall be installed between girders. Utilities and supports shall not extend below the bottom of the superstructure. Utilities shall be installed no lower than 1 foot 0 inches above the bottom of the girders. In some cases when appurtenances are required (such as air release valves), care shall be taken to provide adequate space. The utility installation shall be located so as to minimize the effect on the appearance of the structure. Utilities shall not be attached above the bridge deck nor attached to the railings or posts.

10.8.2.B Termination at the Bridge Ends

Utility conduit and encasements shall extend 10 feet minimum beyond the ends of the structure in order to reduce effects of embankment settlement on the utility and provide protection in case of future work involving excavation near the structure. This requirement shall be shown on the plans. Utilities off the bridge must be installed prior to paving of approaches. This should be stated in the Special Provisions.

10.8.2.C Utility Expansion

The utilities shall be designed with a suitable expansion system as required to prevent longitudinal forces from being transferred to bridge members.

Water mains generally remain a constant temperature and are anchored in the ground at the abutments. However, the bridge will move with temperature changes and seismic forces. Pipe support systems shall be designed to allow for the bridge movements. For short bridges, this generally means the bridge will move and the utility will not since it is anchored at the abutments. For long bridges that require pipe expansion joints, design shall carefully locate pipe expansion joints and the corresponding longitudinal load-carrying support.

Electrical conduits that use PVC shall have an expansion device for every 100 foot of pipe due to the higher coefficient of expansion. If more than two joints are specified, a cable or expansion limiting device is required to keep the ends from separating.

10.8.2.D Utility Blockouts

Blockouts shall be provided in all structural members that prohibit the passage of utilities, such as girder end diaphragms, pier crossbeams, and intermediate diaphragms. These blockouts shall be large enough to fit deflection fittings, and shall be parallel to the utility. For multiple utilities, a note shall be added to the plans that the deflection fittings shall be staggered such that no fitting is located adjacent to another, or the blockouts shall be designed to fit both fittings. Expansion fittings shall be staggered.

10.8.2.E Gas Lines or Volatile Fluids

Pipelines carrying volatile fluids through a bridge superstructure shall be designed by the utility company in accordance with [WAC 480-93](#), Gas Companies—Safety, and Minimum Federal Safety Standard, [Title 49](#) Code of Federal Regulations (CFR) Section part 192. [WAC 468-34-210](#), Pipelines—Encasement, describes when casing is required for carrying volatile fluids across structures. Generally, casing is not required for pipelines conveying natural gas per the requirements of [WAC 468-34-210](#). If casing is required, then [WAC 468-34-210](#) and [WAC 480-93-115](#) shall be followed.

10.8.2.F Water Lines

Transverse support or bracing shall be provided for all water lines to carry Strength and Extreme Event Lateral Loading. Fire control piping is a special case where unusual care must be taken to handle the inertial loads and associated deflections. The Utility Engineer shall be involved in the design of supports resisting dynamic action loads and deflections.

In box girders (closed cell), a rupture of a water line will generally flood a cell before emergency response can shut down the water main. This shall be designed for as an Extreme Event II load case, where the weight of water is a dead load (DC). Additional weep holes or open grating shall be considered to offset this Extreme Event (see [Figure 10.8.3-1](#)). Full length casing extending 10-feet beyond the end of the bridge approach slab shall be considered as an alternate to additional weep holes or open grating.

10.8.2.G Sewer Lines

Sewer lines shall meet the same design criteria as waterlines. Encasement pipe is required for sewer lines on bridges that cross over water or roads. See the utility agreement or the Hydraulic Section for types of sewer pipe material typically used.

10.8.2.H Electrical (Power and Communications)

Telephone, television cable, and power conduit shall be galvanized Rigid Metal Conduit (RGS) or Rigid Polyvinyl Chloride Conduit (PVC). Where such conduit is buried in concrete curbs or barriers or has continuous support, such support is considered to be adequate. Where hangers or brackets support conduit at intervals, the maximum distance between supports shall be 5 feet.

10.8.3 Box/Tub Girder Bridges

Utilities shall not be placed inside reinforced concrete box girders with less than 4 feet inside clear height and all precast prestressed concrete tub girders because reasonable access cannot be provided. Utilities shall be located between girders or under bridge deck soffit in these cases. Inspection lighting, access and ventilation shall always be provided in girder cells containing utilities. Refer to the concrete and steel chapters for additional details.

Special utilities (such as water or gas mains) in box girder bridges shall use concrete pedestals. This allows the utility to be placed, inspected, and tested before the deck is cast. See Figure 10.8.3-1. Concrete pedestals consist of concrete supports formed at suitable intervals and provided with some type of clamping device. Continuous supports shall be avoided due to the very high cost and additional dead load to the structure.

Figure 10.8.3-1 Concrete Utility Supports

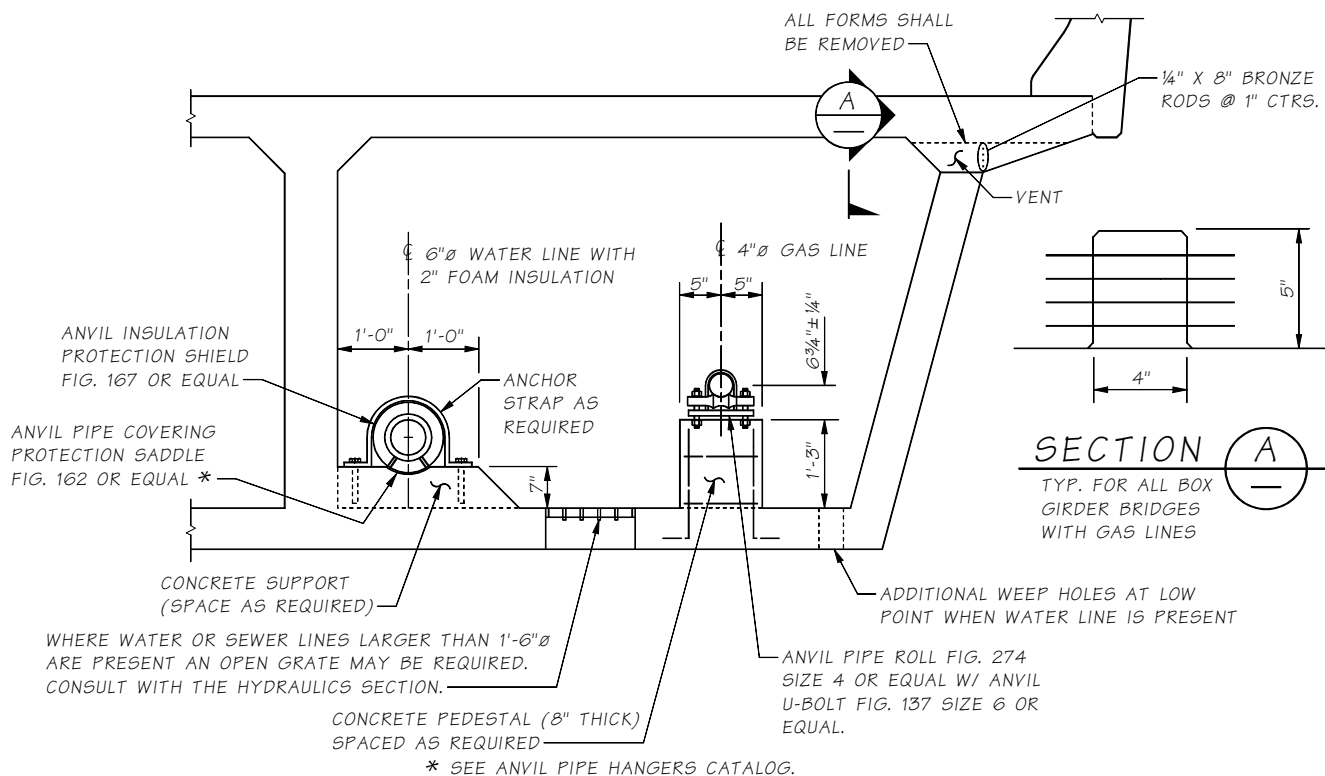

10.8.4 Traffic Barrier Conduit

All new bridge construction shall install two 2-inch galvanized Rigid Metal Conduit (RGS) or Rigid Polyvinyl Chloride Conduit (PVC) in the traffic barriers. These conduits generally carry wiring for Traffic Signals (TS) and Lighting (LT). Other wiring may be installed or the conduit may be used for future applications. PVC conduit may be used only in stationary-form barriers, and will connect to RGS using a PVC adaptor when exiting the barrier. RGS conduit may be used in stationary-form barriers, but it shall be used in slipform barriers.

Each conduit shall be stubbed-out into its own concrete junction box at each corner of the bridge. The Bridge Plans must show the placement of the conduits to clear the structure or any foreseeable obstructions.

The galvanized steel conduit shall be wrapped with corrosion resistant tape at least one foot inside and outside of the concrete structure, and this requirement shall be so stated on the plans. The corrosion resistant tape shall be 3M Scotch 50, Bishop 5, Nashua AVI 10, or approved equal. The usual location of the conduit throughout the remainder of the bridge should be in the traffic barrier.

Pull boxes shall be provided within the barrier for each conduit at each end of the bridge and at a maximum spacing of 200 feet. For fiber optics only, spacing shall not exceed 360 feet. The pull box size shall conform to the specifications of the National Electric Code or be a minimum of 8 inches by 8 inches by 18 inches to facilitate pulling of wires. Galvanized steel pull boxes (or junctions boxes) shall meet the specifications of the "NEMA Type 4X" standard for stationary-form barrier, shall meet the specifications of the "NEMA 3R" and be adjustable in depth for slip form barrier, and the NEMA junction box type shall be stated on the plans. Stainless steel pull boxes may be used as an option to the galvanized steel.

In the case of existing bridges, an area 2 feet in width shall be reserved for conduit beginning at a point either 4 feet or 6 feet outside the face of usable shoulder. The fastening for and location of attaching the conduit to the existing bridge shall be worked out on a job-by-job basis.

10.8.5 Conduit Types

All electrical conduits shall be galvanized Rigid Metal Conduit (RGS) or Rigid Polyvinyl Chloride Conduit (PVC). **Fiberglass conduits are not permitted.**

Steel Pipe – All pipe and fittings shall be galvanized except for special uses.

PVC Pipe – PVC pipe may be used with suitable considerations for deflection, placement of expansion fittings, and of freezing water within the conduits. PVC pipe shall not be placed in concrete traffic barriers when the slip form method is used due to damage and pipe separation that often occurs during concrete placement.

10.8.6 Utility Supports

Selection of a particular support type shall be based on the needs of the installation and the best economy. All utility installations shall address temperature expansion in the design of the system or expansion devices. **Clamped type of supports are not permitted.**

Designs shall provide longitudinal and transverse support for loads from gravity, earthquakes, temperature, inertia, etc. It is especially important to provide transverse and longitudinal support for inserts that cannot resist moment.

Vertical supports shall be spaced at 5 foot maximum intervals for telephone and power conduits, and at a spacing to resist design loads for all other utilities. For Schedule 40 steel conduit, 4" or greater, support spacing may be increased to 8 feet maximum if the design loads permit.

Drilling into prestressed concrete members for utility attachment shall not be allowed.

10.8.6.A Concrete Embedment

This is the best structural support condition and offers maximum protection to the utility. Its cost may be high for larger conduit and the conduit cannot be replaced.

10.8.6.B Pipe Hangers

Utility lines shall be suspended by means of cast-in-place inserts, whenever possible. This is the most common type of support for utilities to be supported under the bridge deck. This allows the use of standard cast-in-place inserts and is very flexible in terms of expansion requirements. For heavy pipes over traffic (10" water main or larger), a Safety Factor of 1.5 should be used to resist vertical loads for Strength Design. This is to avoid complete failure of the utility hanger system by failure of one hanger. Vertical inserts will not provide resistance to longitudinal forces. Longitudinal and transverse supports shall be provided for ITS conduits.

When $\frac{3}{4}$ " or $\frac{7}{8}$ " diameter hanger rods are suspended from cast-in-place inserts, at least three of the following inserts shall be identified: Cooper B-Line B22-I Series, Unistrut 3200 Series, Powerstrut 349 Series, Halfen HT5506 or similar. The specific cast-in-place insert within each series shall be identified based on the required length of insert. The cast-in-place insert shall be at least 6" long and hot dipped galvanized in accordance with AASHTO M 111 or ASTM F2329.

The insert shall not interfere with reinforcement in the bridge deck. The inserts shall be installed level longitudinally and transversely. When the superelevation of the roadway is not significant, a single, long insert may be used to support multiple hanger rods. When the superelevation becomes significant, a single insert may be used for each hanger.

Occasionally large diameter utilities require pipe rolls that only fit on 1" diameter hanger rods. When 1" diameter hanger rods are required, the Anvil Fig. 286 and Unistrut P3246 insert shall be used. The designer shall only specify this insert when absolutely necessary.

The Bridge Engineer shall verify that the cast-in-place insert has sufficient capacity to support the loads from the hanger rod.

Transverse supports may be provided by a second hanger extending from a girder or by a brace against the girder. Bridge Standard Drawings [10.8-A1-1](#) and [10.8-A1-2](#) depict typical utility support installations and placement at abutments and diaphragms. Transverse supports shall, at a minimum, be located at every other vertical support.

10.8.6.C Surface Mounting

Utilities to be installed on existing structures that cannot be located between girders may be mounted under the deck soffit. Utilities shall not be attached above the bridge deck nor attached to the railings or posts. Adhesive anchor shall be used and design in accordance with [Section 10.10](#).

Bridge Standard Drawing [10.8-A1-3](#) shows typical mounting locations for concrete beam of box girder bridges. Anchors shall be located 3" minimum from the edge of deck or other concrete surfaces.

10.9 Review Procedure for Utility Installations on Existing Structures

Utility companies typically submit proposed attachments to WSDOT's structures to the Region's Utility offices, which in turn forward to the Bridge Preservation Office (BPO) for review. BPO is responsible for reviewing only those details pertaining to the bridge crossing such as attachment details or trenching details adjacent to bridge piers or abutments.

The Bridge Preservation Office reviews proposed utility attachments and either approves the attachment or returns for correction (RFC). A current file for most utility attachments is maintained in the Bridge Preservation Office. The turnaround time for reviewing the proposals should not exceed four weeks.

Utility attachments, which exert moments or large forces at the supports, shall be accompanied by at least one set of calculations from the utility company. Bridge attachments designed to resist surge forces shall always be accompanied by calculations. The connection details shall be designed to successfully transfer all forces to the bridge without causing overstress in the connections or to the bridge members to which they are attached. For large utilities, the bridge itself shall have adequate capacity to carry the utility without affecting the live load capacity.

The engineer may request calculations from the utility company for any attachment detail that may be questionable. All plans, details, and calculations shall be stamped, signed, and dated by a Professional Engineer licensed in the State of Washington. Additionally, for heavier utilities, such as waterlines or sewer lines, the engineer may request a load rating of the structure, which shall be stamped, signed, and dated by a licensed professional engineer in the state of Washington to follow the guidelines of [Chapter 13](#). The ratings shall be based solely on the engineer of record calculations.

Guidelines for Utility Companies

Detailing guidelines for utility companies to follow when designing utility attachments are listed in WSDOT Form 224-047, "General Notes and Design Criteria for Utility Installations to Existing Bridges." See [Figure 10.8.1-1](#). See [Section 10.8](#) for other requirements, which include, but are not limited to: design of utility, material used, and spacing of supports.

Water lines and sewer lines installed within box girders shall have full length casing extending 10-feet beyond the end of the bridge approach slab. The casing shall be sufficient to prevent the flooding of a cell upon a utility line rupture.

Guidelines for Column Attachments

The following guidelines shall be followed for installing attachments to columns.

- Attachments on round columns may be either drilled and bolted or banded.
- Attachments on non-circular column shapes shall be drilled and bolted.
- Only percussion drilling methods shall be allowed on bridge columns, and only for small diameter resin bonded anchor installation (0.50" diameter max.). Drilling will normally result in blind holes, and these holes shall be patched with material conforming to *Standard Specifications* Section 6-02.3(20).
- Drilling into prestressed or post-tensioned concrete elements is not permitted. Some WSDOT bridges utilize prestressed columns.

Any proposed conduit installation on a WSDOT bridge structure shall be reviewed and approved by the Risk Reduction Engineer in the Bridge Preservation Office. If the conduit installation originates via a change order, then the Headquarters Construction Office may provide approval, and shall inform the Risk Reduction Engineer of the decision.

10.9.1 Utility Review Checklist

This checklist applies to all proposed utility attachments to existing bridges.

1. Complete cursory check to become familiar with the proposal.
2. Determine location of existing utilities.
 - A. Check Bridge Inspection Report for any existing utilities.
 - B. Check Bridge Preservation's Office's utility file for any existing utility permits or franchises and possible as-built plans.
 - C. Any existing utilities on the same side of the structure as the proposed utility shall be shown on the proposal.
3. Review the following:
 - A. Layout that includes dimension, directions, SR number and bridge number.
 - B. Adequate spacing of supports.
 - C. Adequate strength of supports as attached to the bridge (calculations may be necessary).
 - D. Maximum design pressure and regular operating pressure for pressure pipe systems.
 - E. Adequate lateral bracing and thrust protection for pressure pipe systems.
 - F. Does the utility obstruct maintenance or accessibility to key bridge components?
 - G. Check location (elevation and plan view) of the utility with respect to pier footings or abutments. If trench limits encroach within the 45° envelope from the footing edge, consult the Materials Lab.
 - H. Force mains or water flow systems may require encasement if they are in excavations below the bottom of a footing.
4. Write an email to the Region when "Approved" or "Approved as Noted". Stamp and date the plans using the same date as shown on the email.
5. Create a file folder on the server under Risk Reduction\Utilities with the bridge number. For each utility on the same structure, create a subfolder with utility name. Place approved plans and any other pertinent information used in the review process in the folder.

10.10 Anchors for Permanent Attachments

Cast-in-place concrete anchors are the preferred option for new construction in bridge applications.

The design procedure for cast-in-place and post-installed anchors shall be in accordance with LRFD-BDS 5.13. Adhesive and undercut anchors shall meet the assessment criteria in accordance with ACI 355.4 and ACI 355.2, respectively.

WSDOT allows conventional adhesive anchors systems (resin bonded anchors) and post installed undercut anchors for permanent attachments in many aspects of bridge design, including the permanent cyclical or sustained tension applications listed below.

- Bridge mounted sign brackets with a maximum cantilever length or total span of 10 feet.
- Light standards with a maximum cantilever length of 16 feet.
- Sign structures with a supporting, round or rectangular, post or beam with a maximum dimension of 8 inches.
- Retrofitted corbels for bridge approach slabs.
- Supporting utilities under bridges, including water pipes, electrical conduit and other utility piping systems.

Adhesive anchors shall not be used in monotube sign structure, sign structure truss, and mast arm type signal standard applications. Fast set resin bonding materials shall not be used for adhesive anchors.

For carbon steel undercut anchors, hot-dip galvanized components are preferred, but not currently available from suppliers. Undercut anchors with electroplated zinc coatings are not considered equivalent or better and shall not be used. Therefore, stainless steel undercut anchors are the preferred option.

Expansion anchors and mechanical anchors are not allowed for any permanent applications, except for specific connection details previously approved by the Bridge and Structures Office for precast concrete panel faced structural earth walls as low risk applications.

10.11 Drainage Design

Even though it is rare that poor drainage is directly responsible for a structural failure, it still must be a primary consideration in the design. Poor drainage can cause problems such as ponding on the roadway, erosion around abutments, and early deterioration of structural members. Collecting the runoff and transporting it away from the bridge can prevent most of the problems, thus reducing future maintenance and rehabilitations costs. Proper geometrics during the preliminary stage is essential in order to accomplish this. The Bridge and Structures Office recommends placing the bridge deck drainage off of the structure. All expansion joints shall be watertight.

10.11.1 Geometrics

Bridges shall have sufficient transverse and longitudinal slopes to allow the water to run quickly to the drains. A transverse slope of .02'/ft and longitudinal slope of 0.5 percent for minimum valves are required for new bridges. Avoid placing sag vertical curves and superelevation crossovers on the structure that could result in hydroplaning conditions or, in cold climates, sheets of ice from melting snow. The use of unsymmetrical vertical curves may assist the designer in shifting the low point off the structure.

10.11.2 Hydrology

Contact the Hydraulic Branch for hydraulic design requirements.

10.11.3 On Bridge Systems

Drains shall only be placed on bridge structures when required by bridge deck drainage hydraulics analysis and where alignment and superelevation geometry cannot be adjusted to compensate. Coordinate with the Hydraulics designer for the drainage needs associated with bridge decks and to determine the type of drain required (preferably Neenah).

10.11.4 Construction

See [Standard Specifications](#) Section 6-02.3(10)D5 for construction requirements including gutter texture. Gutters shall have an untextured finish (steel trowel).

10.12 Bridge Security

10.12.1 General

Security based bridge design and its direct correlation to modern social issues is addressed in this section. Criminal activity, illegal encampments, graffiti, hindrance to economic development and public eyesore create unwanted expensive. They also pose public health concerns and safety hazards for State Maintenance and Operations practices. The issue exists in urban areas as well as rural and recreational locales.

Bridges are dominant structures in landscapes. They are held to a higher standard of design due to their influence on communities, where economic and social settings are affected by their quality. Initial project cost savings may quickly be overshadowed by increased externalized costs. These externalized costs are born by local municipalities and businesses as well as other departments within WSDOT.

WSDOT bridge inspectors are required to inspect all bridges at least once every 24 months. The presence of the illegal encampments, as well as garbage, hypodermic needles, and feces often makes it impossible to do a close, hands-on inspection of the abutments and bearings of bridges. The Bridge Preservation Office has requested that maintenance clean up transient camps when it becomes difficult or impossible to do an adequate inspection of the bridges. Campfires set by the homeless have also caused damage to bridges.

Bridge Maintenance Crews also face the same difficulty when they need to do repair work on bridges in the urban area. Clean up requires (per law) posting the bridge seventy-two hours prior to any work. Material picked up is tagged, bagged, and stored for retrieval. Often the offenders are back the next day.

10.12.2 Design

Design is determined on a case by case basis using two strategies. These strategies are universally accepted best practices. The first, Crime Prevention through Environmental Design (CPTED), is a multi-disciplinary approach to deterring criminal behavior.

The second, Context Sensitive Design (CSS), is also multi-disciplinary and focuses on project development methods. Multi-disciplinary teams consist of engineers and architects but may include law enforcement, local businesses, social service providers, and psychologists.

1. CPTED principals are based upon the theory that the proper design and effective use of the built environment can reduce crime, reduce the fear of crime, and improve the quality of life. Built environment implementations of CPTED seek to dissuade offenders from committing crimes by manipulating the built environment in which those crimes proceed from or occur. The six main concepts are territoriality, surveillance, access control, image/maintenance, activity support and target hardening. Applying all of these strategies is key when preventing crime in any neighborhood or right-of-way.

Natural surveillance and access control strategies limit the opportunity for crime. Territorial reinforcement promotes social control through a variety of measures. These may include enhanced aesthetics or public art. Image/maintenance and activity support provide the community with reassurance and the ability to stop crime by

themselves. Target hardening strategies may involve fencing or concrete enclosures or they may include all techniques to resolve crime or chronic trespass into one final step.

2. WSDOT implements FHWA's CSS design development principles through Executive Order E 1028. The CSS methods require designers to consider the physical, economic, and social setting of a project. Stakeholder's interests are to be accounted for; including area residents and business owners.

10.12.3 Design Criteria

New bridges need to address design for the environment by basic criteria:

- Slopes under bridges need to be steep; around a 1:1 slope, and hardened with something like solid concrete so that flat areas cannot be carved into the hillside. Flat areas under bridge superstructures attract inappropriate uses and should be omitted.
- Illegal urban campers have been known to build shelters between the concrete girders. Abutment walls need to be high enough that they deny access to the superstructure elements. When it is not feasible to design for deterrence the sites need to be hardened with fencing buried several feet into the soil or with solid concrete walls. See Figures 14.2.3a and 14.2.3b for high security fence and concrete wall examples.
- Regular chain link is easy cut, therefore stouter material needs to be specified.
- Landscape design should coordinate with region or headquarters landscape architects. Areas need to be visible to law enforcement.

'High security' proprietary fence designs may be employed, or unique case-by-case custom designs may be required. Where required, coordinate with the State Bridge and Structures Architect.

10.13 Temporary Bridges

10.13.1 General

Temporary bridges are defined as bridges that are in service for 5 years or less. Any bridge that is expected to be in service for more than five years shall be designed using the requirements for permanent structures. These requirements apply to all temporary bridges regardless of the delivery contracting methods.

The approaches to the temporary bridge, including but not limited to, slopes, reinforced slopes, and retaining walls, shall be designed in accordance with the WSDOT [Geotechnical Design Manual](#).

10.13.2 Design

10.13.2.A One To Two Construction Season Temporary Bridges

Temporary bridges that will be used for one to two construction seasons shall be designed in accordance with the GSP in the Contract special provisions and shall be designed by the Contractor.

Bridges of this type shall be shown on the Bridge Preliminary Plan and shall include the minimum required length and minimum roadway width including shoulders.

Temporary bridges on 30,000 or greater ADT routes may be required to be designed as a long term, three to five season temporary bridge, as stated below.

10.13.2.B Three To Five Construction Season Temporary Bridges

Temporary bridges of this category shall be designed in accordance with the requirements of the current editions of:

- LRFD-BDS and interims LRFD-SGS
- WSDOT *Bridge Design Manual*, including all design memorandums
- WSDOT [Geotechnical Design Manual](#)

10.13.2.B.1 Design Requirements

The design of the temporary bridge shall not include an additional future overlay of 25 pound per square foot.

Except for project specific conditions for lack of a practical freight route detour, the live loading of the temporary bridge may be reduced to 75-percent of the HL-93 loading, consistent with the Temporary Bridge General Special Provision. If it is determined during design that there is no practical detour route available for freight traffic impacted by this 75-percent HL-93 live load restriction, then the temporary bridge live load shall be specified as 100-percent of the HL-93 loading, and this project specific live load shall be specified in the General Notes in the Plans. Determination of practical detour routes shall be coordinated with the Region Project Engineer.

10.13.2.B.2 Seismic Design Requirements

The seismic design of temporary bridges shall be in accordance with the requirements of the current edition of LRFD-SGS, except the design response spectra shall be reduced by a factor not greater than 2.5.

The minimum support length provisions shall apply to all temporary bridges.

The Seismic Design Category (SDC) of the temporary bridge shall be obtained on the basis of the reduced/modified response spectrum except that a temporary bridge classified in SDC B, C, or D based on the unreduced spectrum cannot be reclassified to SDC A based on the reduced/modified spectrum.

10.13.2.B.3 Deck Design Requirements

Traffic barriers for temporary bridges shall be designed in accordance with the requirements of the current edition of LRFD-BDS, but not less than TL-3 collision load requirements. The TL demand may be adjusted on a case-by-case basis for vehicle size and speed per LRFD-BDS Tables 13.7.2-1 and 2.

The fall restraint specifications of [WAC 296-155-24615](#) Section 2a requiring minimum vertical height of thirty-nine inches for traffic barriers shall be considered for temporary bridges.

Concrete bridge deck thickness may be reduced to 7 inches for concrete superstructure, and to 7½ inches for steel superstructures.

Epoxy coating requirement for bridge deck reinforcement may be waived for temporary bridges with 2 inch min cover for the top mat of reinforcement.

The driving surface of the temporary bridge shall be durable, skid resistant deck, with an initial skid number of at least 35 and maintaining a skid number of 26 minimum, in accordance with [AASHTO T 242](#). The Contractor shall maintain the temporary bridge, including the driving surface, for the life of the temporary bridge in the project.

10.13.2.B.4 Superstructure Design Requirements

A 3 inch minimum HMA overlay could be used for temporary bridges made of adjacent precast concrete members.

Steel temporary bridges need not be painted.

Fatigue need not be checked for temporary bridges with steel superstructure.

All welding, repair welding, and welding inspection, of steel components of the temporary bridge shall conform to the [Standard Specifications](#) Section 6-03.3(25) and 6-03.3(25)A requirements specified for steel bridges.

Allowable tensile stress for precast-prestressed concrete girders under service limit state load combinations per LRFD-BDS Article 5.9.4.2.2 may be used in lieu of those specified in [Section 5.2.1C](#).

10.13.2.B.5 Foundation Design Requirements

Pile types such as precast, prestressed concrete piles, steel H piles, timber piles, micropiles and steel pipe piles may be used for temporary bridges.

Soldier pile wall with treated timber lagging may be used for temporary bridges.

10.13.3 NBI Requirements

Temporary or re-commissioned bridges used as a detour and in-service longer than 90 days shall receive full National Bridge Inspection Standards (all SI&A data; ex., NBIS inspection, load ratings and scour evaluation). All SI&A data shall be submitted to the Washington State NBI data base within 90 days of opening to vehicle traffic. An “open” bridge is defined as a bridge that is near substantial completion with general highway traffic accessing/operating on the bridge in a configuration that is the final planned configuration.

Phased construction stages, if carrying traffic for 90 days or longer shall fall into these criteria.

Bridges open less than 90 days will need regular “safety” type inspections to ensure the safe operation of traffic on the bridge.

Contracts are to clearly identify the owner and who is responsible for all of this NBIS criteria.

Load ratings for legal trucks and special hauling vehicles are required for temporary and bridges constructed in phased stages. The minimum rating factor shall not be less than 1.0.

10.13.4 Submittal Requirements

The Contractor shall submit drawings and copies of supporting design calculations of the temporary bridge to the Engineer for approval in accordance with [Standard Specifications](#) Section 6-01.9. The submittal shall include an erection plan and procedure in accordance with [Standard Specifications](#) Section 6-03.3(7)A.

Submittals for temporary bridges with total length of more than 200 ft shall be stamped and signed by a Washington State registered Structural Engineer (SE) in accordance with the requirements of [WAC 196-23](#).

The Contractor shall construct the temporary bridge in accordance with the working drawings and erection plan as approved by the Engineer, environmental permit conditions specified in [Standard Specifications](#) Section 1-07.5 as supplemented in the Special Provisions and as shown in the Plans, and in accordance with the details shown in the Plans.

10.14 Bridge Standard Drawings

Sign Structures

- 10.1-A1-1 Monotube Sign Bridge Layout ([PDF 59KB](#)) ([DWG 63KB](#))
- 10.1-A1-2 Monotube Sign Bridge Details 1 ([PDF 61KB](#)) ([DWG 64KB](#))
- 10.1-A1-3 Monotube Sign Bridge Details 2 ([PDF 99KB](#)) ([DWG 80KB](#))
- 10.1-A2-1 Monotube Cantilever Layout ([PDF 48KB](#)) ([DWG 33KB](#))
- 10.1-A2-2 Monotube Cantilever Details 1 ([PDF 97KB](#)) ([DWG 76KB](#))
- 10.1-A2-3 Monotube Cantilever Details 2 ([PDF 54KB](#)) ([DWG 45KB](#))
- 10.1-A3-1 Monotube Balanced Cantilever Layout Details ([PDF 74KB](#)) ([DWG 68KB](#))
- 10.1-A3-2 Monotube Balanced Cantilever Details 1 ([PDF 81KB](#)) ([DWG 74KB](#))
- 10.1-A3-3 Monotube Balanced Cantilever Details 2 ([PDF 67KB](#)) ([DWG 56KB](#))
- 10.1-A4-1 Monotube Sign Structure Foundation Type 1, 1 of 2 ([PDF 107KB](#)) ([DWG 81KB](#))
- 10.1-A4-2 Monotube Sign Structure Foundation Type 1, 2 of 2 ([PDF 132KB](#)) ([DWG 100KB](#))
- 10.1-A4-3 Monotube Sign Structure Foundation Types 2 & 3 ([PDF 85KB](#)) ([DWG 133KB](#))
- 10.1-A5-1 General Notes ([PDF 104KB](#)) ([DWG 75KB](#))
- 10.1-A5-2 Monotube Sign Structures Common Details ([PDF 108KB](#)) ([DWG 94KB](#))
- 10.1-A5-3 Monotube Sign Structure Single Slope Traffic Barrier Shape Cap ([PDF 104KB](#)) ([DWG 75KB](#))

Bridge Mounted Sign Bracket

- 10.1-A6-1 Bridge Mounted Sign Bracket No. 1 - Layout ([PDF 69KB](#)) ([DWG 97KB](#))
- 10.1-A6-2 Bridge Mounted Sign Bracket No. 1 - Geometry ([PDF 69KB](#)) ([DWG 97KB](#))
- 10.1-A6-3 Bridge Mounted Sign Bracket Details 1 of 3 ([PDF 116KB](#)) ([DWG 123KB](#))
- 10.1-A6-4 Bridge Mounted Sign Bracket Details 2 of 3 ([PDF 109KB](#)) ([DWG 84KB](#))
- 10.1-A6-4a Bridge Mounted Sign Bracket Details 2 of 3 ([PDF 75KB](#)) ([DWG 84KB](#))
- 10.1-A6-4b Bridge Mounted Sign Bracket Details 2 of 3 ([PDF 92KB](#)) ([DWG 86KB](#))
- 10.1-A6-4c Bridge Mounted Sign Bracket Details 2 of 3 ([PDF 99KB](#)) ([DWG 73KB](#))
- 10.1-A6-5 Bridge Mounted Sign Brackets ([PDF 142KB](#)) ([DWG 214KB](#))

Traffic Barriers

- 10.2-A1-1 Shape F Traffic Barrier Detail 1 of 3 ([PDF 86KB](#)) ([DWG 84KB](#))
- 10.2-A1-2 Shape F Traffic Barrier Detail 2 of 3 ([PDF 80KB](#)) ([DWG 71KB](#))
- 10.2-A1-3 Shape F Traffic Barrier Detail 3 of 3 ([PDF 92KB](#)) ([DWG 136KB](#))
- 10.2-A2-1 Shape F Traffic Barrier on Flat Slab Details 1 of 3
([PDF 137KB](#)) ([DWG 291KB](#))
- 10.2-A2-2 Shape F Traffic Barrier on Flat Slab Details 2 of 3
([PDF 129KB](#)) ([DWG 151KB](#))
- 10.2-A2-3 Shape F Traffic Barrier on Flat Slab Details 3 of 3
([PDF 157KB](#)) ([DWG 305KB](#))
- 10.2-A3-1 Single Slope Traffic Barrier Details 1 of 3 ([PDF 92KB](#)) ([DWG 80KB](#))
- 10.2-A3-2 Single Slope Traffic Barrier Details 2 of 3 ([PDF 86KB](#)) ([DWG 65KB](#))
- 10.2-A3-3 Single Slope Traffic Barrier Details 3 of 3 ([PDF 94KB](#)) ([DWG 136KB](#))
- 10.2-A4-1 Pedestrian Barrier Details, 1 of 3 ([PDF 91KB](#)) ([DWG 75KB](#))
- 10.2-A4-2 Pedestrian Barrier Details, 2 of 3 ([PDF 75KB](#)) ([DWG 74KB](#))
- 10.2-A4-3 Pedestrian Barrier Details, 3 of 3 ([PDF 91KB](#)) ([DWG 133KB](#))
- 10.2-A5-1A Traffic Barrier Shape F 42", (TL-4) 1 of 3 ([PDF 99KB](#)) ([DWG 97KB](#))
- 10.2-A5-1B Traffic Barrier Shape F 45", (TL-5) 1 of 3 ([PDF 99KB](#)) ([DWG 97KB](#))
- 10.2-A5-2 Traffic Barrier Shape F 42", (TL-4 or TL-5), 2 of 3 ([PDF 95KB](#)) ([DWG 83KB](#))
- 10.2-A5-3 Traffic Barrier Shape F 42", (TL-4 or TL-5), 3 of 3 ([PDF 94KB](#)) ([DWG 139KB](#))
- 10.2-A6-1 Traffic Barrier - Single Slope 45" TL5 1 of 3
- 10.2-A6-2 Traffic Barrier - Single Slope 45" TL5 2 of 3
- 10.2-A6-3 Traffic Barrier - Single Slope 45" TL5 3 of 3

Luminaire

- 10.2-A7-1 Luminaire on F Shape Traffic Barrier ([PDF 169KB](#)) ([DWG 200KB](#))
- 10.2-A7-2 Luminaire on Single Slope Traffic Barrier ([PDF 167KB](#)) ([DWG 470KB](#))

Rail Retrofits

- 10.4-A1-1 Thrie Beam Retrofit Concrete Baluster ([PDF 67KB](#)) ([DWG 191KB](#))
- 10.4-A1-2 Thrie Beam Retrofit Concrete Railbase ([PDF 56KB](#)) ([DWG 84KB](#))
- 10.4-A1-3 Thrie Beam Retrofit Concrete Curb ([PDF 57KB](#)) ([DWG 250KB](#))
- 10.4-A1-4 WP Thrie Beam Retrofit SL1 - Details 1 of 2 ([PDF 61KB](#)) ([DWG 75KB](#))
- 10.4-A1-5 WP Thrie Beam Retrofit SL1 - Details 2 of 2 ([PDF 61KB](#)) ([DWG 78KB](#))
- 10.4-A2-1 TB Shape F Rehab - Details 1 of 3 ([PDF 107KB](#)) ([DWG 100KB](#))
- 10.4-A2-2 TB Shape F Rehab - Details 2 of 3 ([PDF 127KB](#)) ([DWG 157KB](#))
- 10.4-A2-3 TB Shape F Rehab - Details 3 of 3 ([PDF 158KB](#)) ([DWG 172KB](#))

Railings

- 10.5-A1-1 Bridge Railing Type Pedestrian Details 1 of 2 ([PDF 67KB](#)) ([DWG 58KB](#))
- 10.5-A1-2 Bridge Railing Type Pedestrian Details 2 of 2 ([PDF 81KB](#)) ([DWG 75KB](#))
- 10.5-A2-1 Bridge Pedestrian Railing Type BP Details 1 of 2 ([PDF 67KB](#)) ([DWG 60KB](#))
- 10.5-A2-2 Bridge Pedestrian Railing Type BP Details 2 of 2 ([PDF 81KB](#)) ([DWG 75KB](#))
- 10.5-A3-1 Pedestrian Railing Type BP-Steel Details 1 of 2 ([PDF 86KB](#)) ([DWG 106KB](#))
- 10.5-A3-2 Pedestrian Railing Type BP-Steel Details 2 of 2 ([PDF 120KB](#)) ([DWG 157KB](#))
- 10.5-A4-1 Pedestrian Railing Details 1 of 2 ([PDF 103KB](#)) ([DWG 126KB](#))
- 10.5-A4-2 Pedestrian Railing Details 2 of 2 ([PDF 108KB](#)) ([DWG 121KB](#))
- 10.5-A5-2 Bridge Railing Type Snow Fence Details 1 of 2 ([PDF 122KB](#)) ([DWG 64KB](#))
- 10.5-A5-3 Bridge Railing Type Snow Fence Details 2 of 2 ([PDF 131KB](#)) ([DWG 63KB](#))
- 10.5-A5-4 Bridge Railing Type Chain Link Fence ([PDF 97KB](#)) ([DWG 62KB](#))
- 10.5-A6-1 Bridge Railing Type BP-12 Details 1 of 2 ([PDF 106KB](#)) ([DWG 53KB](#))
- 10.5-A6-2 Bridge Railing Type BP-12 Details 2 of 2 ([PDF 104KB](#)) ([DWG 51KB](#))
- 10.5-A7-1 Bridge Railing Type S-BP-12 Details 1 of 2 ([PDF 88KB](#)) ([DWG 43KB](#))
- 10.5-A7-2 Bridge Railing Type S-BP-12 Details 2 of 2 ([PDF 119KB](#)) ([DWG 64KB](#))

Approach Slabs

- 10.6-A1-1 Approach Slab Detail 1 of 3 ([PDF 125KB](#)) ([DWG 113KB](#))
- 10.6-A1-2 Approach Slab Detail 2 of 3 ([PDF 72KB](#)) ([DWG 132KB](#))
- 10.6-A1-3 Approach Slab Detail 3 of 3 ([PDF 147KB](#)) ([DWG 238KB](#))
- 10.6-A2-1 Concrete Pavement Seat Repair ([PDF 98KB](#)) ([DWG 103KB](#))
- 10.6-A2-2 T-Section Pavement Seat Repair ([PDF 97KB](#)) ([DWG 106KB](#))

Utility Hangers

- 10.8-A1-1 Utility Hanger Details for PS Concrete Girders ([PDF 120KB](#)) ([DWG 192KB](#))
- 10.8-A1-2 Utility Hanger Details for Concrete Box ([PDF 94KB](#)) ([DWG 150KB](#))
- 10.9-A1-1 Guide to Utility Hanger Details ([PDF 97KB](#)) ([DWG 132KB](#))

Bridge Drains

- 10.11-A1-1 Bridge Drain Modification ([PDF 72KB](#)) ([DWG 94KB](#))
- 10.11-A1-2 Bridge Drain Type 2 thru 5 ([PDF 72KB](#)) ([DWG 94KB](#))

10.99 References

AASHTO Guide Specification for *LRFD Seismic Bridge Design*, 3rd Edition, 2023

AASHTO, *LRFD Bridge Design Specifications*, 9th Edition, 2020

AASHTO *Standard Specifications for Highway Bridges*, 17th Edition (2002), Washington DC.

NCHRP Report 230, "Recommended Procedures for the Safety Performance Evaluation of Highway Appurtenances", Transportation Research Board, 1991, Washington DC.

NCHRP Report 350, "Recommended Procedures for the Safety Performance Evaluation of Highway Features", Transportation Research Board, 1993, Washington DC.

NCHRP Report 663, "Design of Roadside Barrier Systems Placed on MSE Retaining Walls", NCHRP Project 22-20, Transportation Research Board, 2010, Washington DC.

WSDOT *Design Manual*

WSDOT *Geotechnical Design Manual*

WSDOT *Standard Plans*

WSDOT *Standard Specifications for Road, Bridge, and Municipal Construction (Standard Specifications)*

WSDOT E 1028 *Context Sensitive Solutions Executive Order*

Newman, O. *Defensible Space: Crime Prevention Through Urban Design*. New York: Macmillan. 1972

Jacobs, Jane. *The Death and Life of Great American Cities*. New York: Random House. 1961