

FINAL ENVIRONMENTAL IMPACT STATEMENT
AND FINAL SECTION 4(f) AND 6(f) EVALUATIONS
SR 520 BRIDGE REPLACEMENT AND HOV PROGRAM

MAY 2011

SR 520, I-5 to Medina: Bridge Replacement and HOV Project

Noise Discipline Report Addendum and Errata

**SR 520, I-5 to Medina:
Bridge Replacement and HOV Project
Final Environmental Impact Statement
and Final Section 4(f) and 6(f) Evaluations**

**Noise Discipline Report
Addendum and Errata**



Prepared for
Federal Highway Administration
Washington State Department of Transportation

Consultant Team
Parametrix, Inc.
CH2M HILL
HDR Engineering, Inc.
Parsons Brinckerhoff
ICF Jones & Stokes
Confluence Environmental Company, Inc.
Michael Minor and Associates
PRR, Inc.
Critigen

May 2011

Contents

Introduction	1
What is the purpose of this addendum?	1
What key issues were identified in the public and agency comments on the SDEIS?	1
What are the key points of this addendum?.....	1
What is the SR 520, I-5 to Medina: Bridge Replacement and HOV Project?	4
What is the Preferred Alternative?	4
When will the project be built?.....	10
Are pontoons being constructed as part of this project?.....	11
Noise Analysis Overview.....	11
What is sound (noise)?.....	11
When is a noise study performed?	14
What were the methods used to evaluate the potential effects and how have they changed since publication of the SDEIS?.....	14
What project coordination was performed?	16
What criteria are used to evaluate potential effects?.....	17
Affected Environment.....	19
What were the updates to the affected environment?	19
How do other local projects affect the results of this study?.....	20
What are the existing sound characteristics of the study area?	21
Why are the sound measurements conducted?	26
Where are the sound measurement locations?.....	26
What methods were used for the sound measurements?.....	26
What methods were used for the noise modeling?	26
Where are the noise modeling locations?	27
What are the existing peak-hour traffic noise levels?.....	28
Potential Effects.....	29
How would construction of the project affect noise levels?.....	29
How would operation of the project affect noise levels?.....	42
Noise Abatement.....	73
What has been done to avoid or minimize negative effects from noise?	73
What noise walls are recommended for the Preferred Alternative?.....	77
What construction noise abatement and vibration mitigation is normally considered?	88
What negative effects would remain after noise abatement?	90
References	91



Attachments

- 1 Noise Discipline Report Errata
- 2 Residential-Equivalent Calculations for the Project Study Area
- 3 Noise Modeling Locations, Levels and Changes in Project Study Area
- 4 WSDOT Special Noise Barrier Applications Phase II
- 5 Noise Model Validation Summary for the Project Study Area
- 6 Capital Hill Noise Wall Review
- 7 Comparison of Modeled Noise Levels: Preferred Alternative with Options A, K, and L

List of Exhibits

- 1 Number of Residences or Residential Equivalents Where Noise Levels Would Approach or Exceed NAC
- 2 Rounding the Preferred Alternative Effects with Noise Walls
- 3 Preferred Alternative Project Elements
- 4 Preferred Alternative and Comparison to SDEIS Options
- 5 Preferred Alternative Construction Stages and Durations
- 6 Sound Levels and Relative Loudness of Typical Noise Sources
- 7 FHWA and WSDOT Noise Abatement Criteria Table
- 8 Neighborhood Designations Used in Analysis (Update to Exhibit 11 of the 2009 Discipline Report)
- 9 Washington State Noise Control Regulation
- 10 Washington State – Exemptions for Short-Term Noise Exceedances
- 11 City of Seattle – Maximum Permissible Sound Levels
- 12 City of Seattle – Exemptions for Short-Term Noise Exceedances
- 13 City of Seattle – Allowable Exceedances for Construction and Equipment Operations
- 14 City of Seattle – Maximum Noise Levels for Impact Types of Construction Equipment
- 15 Peak Particle Velocity Guidelines
- 16 Construction Equipment List, Use, and Reference Maximum Noise Levels
- 17 Noise Levels for Typical Construction Phases at 50 Feet from Work Site



- 18 Estimated Hourly Maximum Construction Noise for Different Distances from Construction Site
- 19 Estimated Typical Maximum Pile-Driving Noise Levels, Assuming 105 dBA at 50 Feet
- 20 Maximum Pile-Driving Noise in the Study Area
- 21 Traffic Noise Modeling Locations and Levels in Portage Bay, Roanoke, and North Capitol Hill Neighborhoods
- 22 Traffic Noise Modeling Locations and Levels in Montlake North
- 23 Traffic Noise Modeling Locations and Levels in Montlake South
- 24 Traffic Noise Modeling Locations and Levels in the University of Washington
- 25 Traffic Noise Modeling Locations and Levels in the Washington Park Arboretum, Madison Park, and Laurelhurst Neighborhoods
- 26 Traffic Noise Modeling Locations and Levels in the Medina North and South Neighborhoods
- 27 Sound Level Changes in the Study Area
- 28 Preferred Alternative 2030 Peak-Hour Traffic Noise Levels for Portage Bay/Roanoke
- 29 Preferred Alternative 2030 Peak-Hour Traffic Noise Levels for North Capitol Hill
- 30 Preferred Alternative 2030 Peak-Hour Traffic Noise Levels for Montlake North of SR 520
- 31 Preferred Alternative 2030 Peak-Hour Traffic Noise Levels for Montlake South of SR 520
- 32 Preferred Alternative 2030 Peak-Hour Traffic Noise Levels for the University of Washington
- 33 Preferred Alternative 2030 Peak-Hour Traffic Noise Levels for the Washington Park Arboretum
- 34 Preferred Alternative 2030 Peak-Hour Traffic Noise Levels for Madison Park
- 35 Preferred Alternative 2030 Peak-Hour Traffic Noise Levels for Laurelhurst
- 36 Preferred Alternative 2030 Peak-Hour Traffic Noise Levels for Medina North of SR 520
- 37 Preferred Alternative 2030 Peak-Hour Traffic Noise Levels for Medina South of SR 520
- 38 Locations of 4-foot Tall Concrete Traffic Barriers with Noise-Absorptive Materials for the Preferred Alternative in the I-5 to West Approach Area
- 39 Sound Level Changes in the Medina Area with Noise Abatement
- 40 Noise Wall Locations and Heights for the Preferred Alternative in the Eastside Transition Area



- 41 Noise Wall Performance Summary for Preferred Alternative
- 42 Details and Cost Analysis for Preferred Alternative Noise Walls



Acronyms and Abbreviations

ANSI	American National Standards Institute
CFR	Code of Federal Regulations
dB	decibel
dba	decibel, A-weighted
EIS	environmental impact statement
FHWA	Federal Highway Administration
HCT	high-capacity transit
HOV	high-occupancy vehicle
I-5	Interstate 5
Leq	equivalent sound level
KCC	King County Code
mph	miles per hour
NAC	Noise Abatement Criteria
NIST	National Institute of Standards and Testing
NOAA	National Oceanic and Atmospheric Administration
NWFSC	Northwest Fisheries Science Center
SDEIS	Supplemental Draft Environmental Impact Statement
SR	State Route
TNM	Traffic Noise Model
USDOT	U.S. Department of Transportation
WAC	Washington Administrative Code
WSDOT	Washington State Department of Transportation



Introduction

What is the purpose of this addendum?

This addendum to the 2009 Noise Discipline Report (Washington State Department of Transportation [WSDOT] 2009a), which was prepared in support of the SR 520, I-5 to Medina: Bridge Replacement and HOV Project Supplemental Draft Environmental Impact Statement (SDEIS; WSDOT 2010), presents the environmental consequences of the Preferred Alternative, updates the noise model for the existing conditions and No Build Alternative based on new information presented in the Puget Sound Regional Council 2040 Transportation Plan and updated land use information for Medina, and incorporates additional discussion resulting from public and agency comments received on the SDEIS.

The noise analysis overview, methodologies, and affected environment information contained in the Noise Discipline Report are still pertinent to the Preferred Alternative and its effects, except where this addendum specifically updates the information. This addendum supplements the Noise Discipline Report by disclosing the results of an updated noise modeling and analysis for the existing conditions, the No Build and Preferred Alternatives, and updates noise recommendations based on the new analyses results. New information used in the analysis of potential effects includes the Description of Alternatives Discipline Report Addendum (WSDOT 2011a) and the Construction Techniques and Activities Discipline Report Addendum and Errata (WSDOT 2011b). New information used in determining noise abatement measures includes an updated accounting of the residences in the Medina neighborhood due to the relocation of several structures along the north side of SR 520.

What key issues were identified in the public and agency comments on the SDEIS?

An errata sheet is attached to this addendum as Attachment 1 to show corrections and clarifications to the 2009 Noise Discipline Report that do not constitute new findings or analysis.

What are the key points of this addendum?

Overall, with the Preferred Alternative with the project's noise reducing design elements and recommended noise abatement measures, there are a predicted 143 residences and residential equivalents that would have noise levels that meet or exceed WSDOT's Noise Abatement Criteria (NAC). With the project's noise-reducing design elements, which include lids, reduced speed on the Portage Bay Structure, and tall traffic safety barriers, there would be no negative effects remaining in Laurelhurst or Madison Park. With the recommended noise abatement measures in Medina, no negative effects would remain under the Preferred Alternative in Medina.



Exhibit 1 provides the number of residences or residential equivalents where noise levels would approach or exceed NAC for each of the alternatives.

Exhibit 1. Number of Residences or Residential Equivalents Where Noise Levels Would Approach or Exceed NAC

(% of residences where noise levels would approach or exceed NAC based on the total residences identified in the study area)^{a,b}

	Alternatives					
	Current	No Build Alternative	Option A	Option K	Option L	Preferred Alternative
Without Noise Abatement or Noise Reducing Design Elements	270 (32.3%)	287 (34.3%)	249 (29.0%)	256 (29.8%)	235 (27.5%)	207 (24.7%)
With Noise Abatement and Reducing Design Elements	—	—	94 (11.0%)	123 (14.4%)	119 (13.9%)	143 (17.0%)

^a The percentages of residences are based on a total of 858 residences for Options A and K, 855 residences for Option L, and 838 residences for the Current, No Build, and Preferred Alternatives.

^b Residences and Residential Equivalents are rounded to nearest whole value.

With the Preferred Alternative, there would be 22 affected residences within the Portage Bay/Roanoke neighborhood. In addition, 44 residences within the North Capitol Hill neighborhood would have noise levels approaching or exceeding the NAC under the Preferred Alternative with the project's noise reducing design elements.

The number of affected residences within the Montlake neighborhoods north and south of State Route (SR) 520 would be 28 and 39, respectively, under the Preferred Alternative with the project's noise reducing design elements. Within the University of Washington, the number of affected residences (four) remains the same as the No Build Alternative once the project's noise reducing design elements are included. With the Preferred Alternative, only five residential equivalents within the Arboretum would have noise levels approaching or exceeding the NAC, due in part to the project's noise reducing design elements.

Overall, the number of affected residences under the Preferred Alternative without the recommended noise walls or the 4-foot concrete traffic barrier would be significantly lower than the number under either the No Build Alternative or the SDEIS options without mitigation. However, the number of affected residences under the Preferred Alternative with the traffic barrier and noise walls is somewhat higher when compared to any of the SDEIS options with mitigation. This is primarily because the project design elements reduce noise to levels where other noise abatement, such as noise walls, is no longer feasible and reasonable. Project design elements that would reduce noise along the corridor include 4-foot tall concrete traffic barriers with noise-absorptive materials along the project alignment, reduced speeds between Interstate 5 (I-5) and the Montlake lid, increased heights of the elevated roadways, and expanded lids. By reducing noise levels, these same Preferred Alternative elements reduce the number of recommended noise walls compared to those



recommended under the SDEIS options. In short, in those areas where the number of affected residences is higher with the Preferred Alternative compared to the SDEIS options, the difference is primarily because no noise walls are recommended under the Preferred Alternative, whereas noise walls were recommended with one or more of the SDEIS options.

Since publication of the SDEIS, WSDOT has acquired and relocated several homes in the Medina area. Detailed counts of residences in the City of Medina were performed using the King County Parcel Viewer, <http://www5.kingcounty.gov/parcelviewer/viewer/kingcounty/viewer.asp>. All residential equivalents were reviewed for accuracy. As a result of these count updates, under the Final EIS traffic noise analysis, sound levels were modeled at 230 locations, representing 837.8 residences and residential equivalents. This is in comparison to 211 modeling locations representing 862 residences and residential equivalents used in the Draft Environmental Impact Statement (EIS).

In addition, note that the number of residences and residential equivalents are presented as whole numbers in most exhibits, and therefore, addition of residences and residential equivalents by segment, may be slightly different than summing all residences and residential equivalents over the whole corridor at once. This is due to rounding. For example, the total number of residences and residential equivalents, if added all together throughout the entire corridor, would result in 142.8 residences and residential equivalents with noise level at or above the noise abatement criteria, which rounds up to 143. However, if first, the residential equivalents by segment are rounded to whole numbers. Then they are added together, to arrive at 142. The higher number was used to represent the residences or residential equivalents eligible for noise abatement. The rounding of Preferred Alternative effects with noise walls is shown in Exhibit 2.

Exhibit 2. Rounding the Preferred Alternative Effects with Noise Walls

Neighborhood	Total Only Rounding	Rounded by Segment
Portage Bay/Roanoke	22.0	22
North Capitol Hill	44.0	44
Montlake North of SR 520	28.0	28
Montlake South of SR 520	39.0	39
University of Washington	4.4	4
Washington Park Arboretum	5.4	5
Madison Park	0.0	0
Laurelhurst	0.0	0
Medina North of SR 520	0.0	0
Medina South of SR 520	0.0	0
Totals	142.8	142
Totals (Rounded)	143	142



What is the SR 520, I-5 to Medina: Bridge Replacement and HOV Project?

The SR 520, I-5 to Medina: Bridge Replacement and HOV Project would widen the SR 520 corridor to six lanes from I-5 in Seattle to Evergreen Point Road in Medina and would restripe and reconfigure the lanes in the corridor from Evergreen Point Road to 92nd Avenue NE in Yarrow Point. It would replace the vulnerable Evergreen Point Bridge (including the west and east approach structures) and Portage Bay Bridge as well as the existing local street bridges across SR 520. The project would complete the regional high-occupancy vehicle (HOV) lane system across SR 520, as called for in regional and local transportation plans. New stormwater treatment facilities would be constructed for the project to provide stormwater treatment.

What is the Preferred Alternative?

The SR 520, I-5 to Medina: Bridge Replacement and HOV Project SDEIS, published in January 2010, evaluated a 6-Lane Alternative with three design options (Options A, K, and L) for the Seattle portion of the SR 520 corridor, and a No Build Alternative. Since the SDEIS was published, WSDOT and the Federal Highway Administration (FHWA) announced a Preferred Alternative for the SR 520, I-5 to Medina project. All components of the Preferred Alternative were evaluated in the SDEIS, and the design of the SR 520 corridor has been further refined in response to comments received during public review of the SDEIS. The Preferred Alternative is summarized below. More information about the Preferred Alternative is provided in the Description of Alternatives Discipline Report Addendum (WSDOT 2011a).

The new SR 520 corridor would be six lanes wide (two 11-foot-wide outer general-purpose lanes and one 12-foot-wide inside HOV lane in each direction), with 4-foot-wide inside shoulders and 10-foot-wide outside shoulders across the floating bridge. In response to community interests expressed during public review of the SDEIS, the SR 520 corridor between I-5 and the Montlake area would operate as a boulevard or parkway a posted speed limit of 45 miles per hour and median planting across the Portage Bay Bridge. To support the boulevard concept, the width of the inside shoulders in this section of SR 520 would be narrowed from 4 feet to 2 feet, and the width of the outside shoulders would be reduced from 10 feet to 8 feet. Exhibit 3 highlights the major components of the SR 520, I-5 to Medina project Preferred Alternative.

The Preferred Alternative design elements that would also provide noise reduction such as a reduced speed limit between I-5 and the Montlake area, 4-foot concrete traffic barriers, noise absorptive material on the inside of the traffic barriers and around the lid portals, and encapsulated bridge joints. The Preferred Alternative, like the SDEIS options, would also include quieter concrete pavement along the mainline between I-5 and the floating bridge. Traffic noise modeling completed for the Final EIS resulted in fewer recommended noise walls for the Preferred Alternative than for the SDEIS options. Noise walls would meet all FHWA and WSDOT requirements for avoidance and



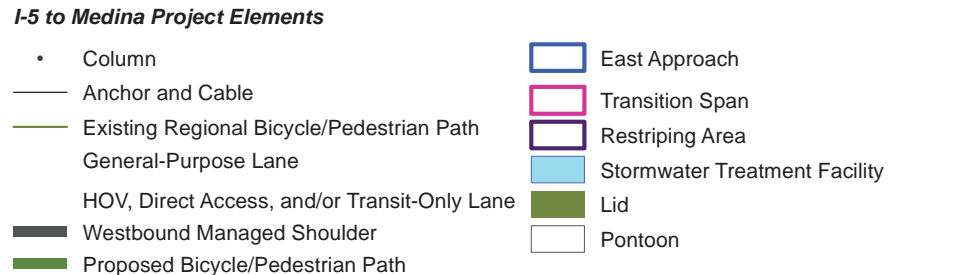
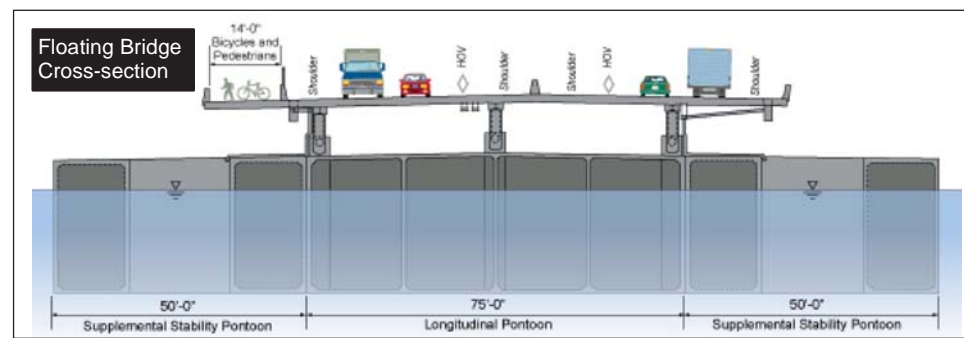
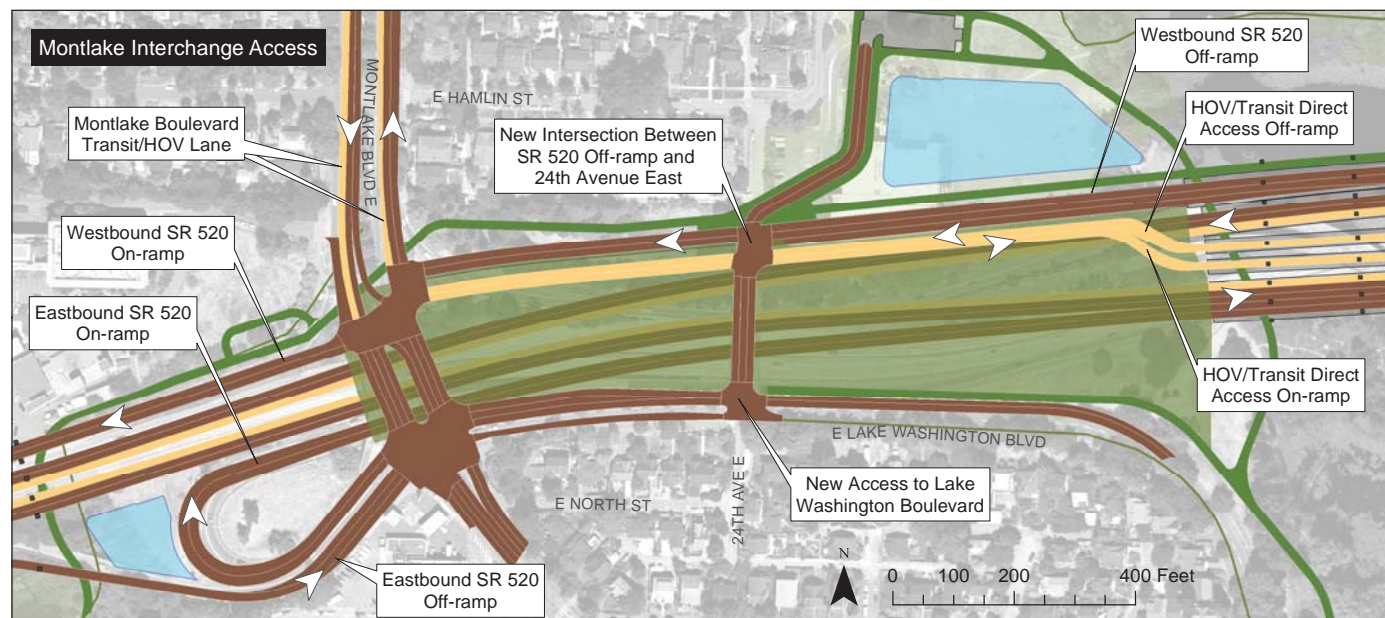
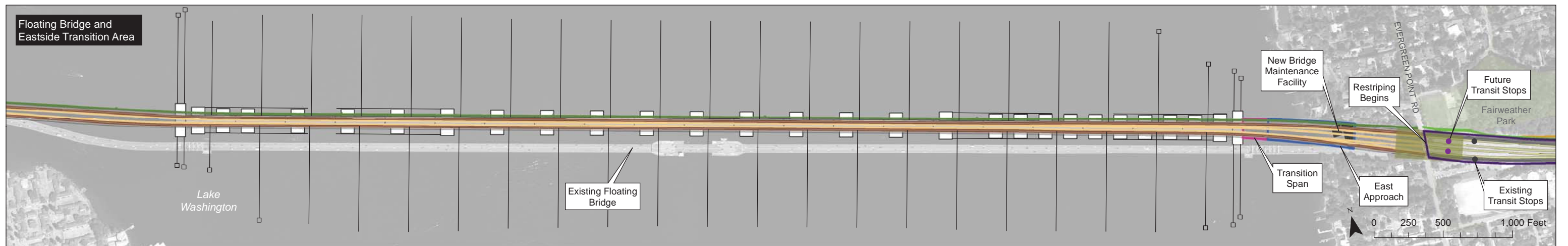
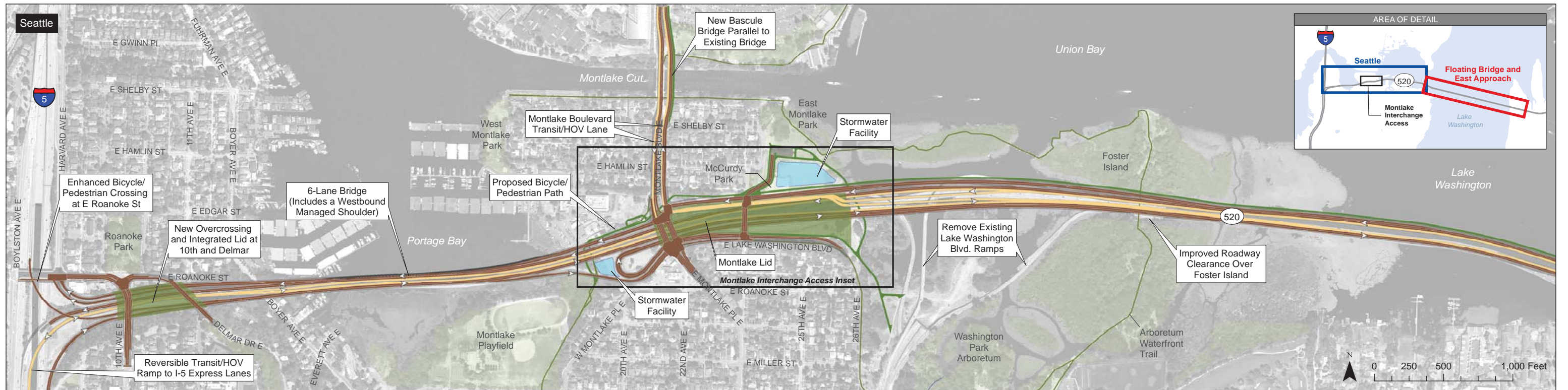

Medina to SR 202 Project Elements

- General-Purpose Lane
- HOV Lane
- Bike Path
- Points Loop Trail
- Medina to SR 202 Project Lid

Source: King County (2006) Aerial Photo, King County (2008) GIS Data (Stream), CH2M HILL (2008) GIS Data (Park). Horizontal datum for all layers is NAD83(91); vertical datum for layers is NAVD88.

Exhibit 3. Preferred Alternative Project Elements

I-5 to Medina: Bridge Replacement and HOV Project

minimization of negative noise effects. In areas where noise walls are warranted, they would only be constructed if approved by the affected communities.

The description and evaluation of the Preferred Alternative and the comparison of the Preferred Alternative to the design options presented in the SDEIS are organized by three areas along the project corridor: Seattle, Lake Washington, and the Eastside. Within these larger areas, project elements are described by geographic area, as identified in Exhibit 4. The project features for the Preferred Alternative are described under the geographic area headings so that the differences between the Preferred Alternative and the SDEIS options can be easily identified and compared.

Exhibit 4. Preferred Alternative and Comparison to SDEIS Options

Geographic Area	Preferred Alternative	Comparison to SDEIS Options A, K, and L
I-5/Roanoke Area	The SR 520 and I-5 interchange ramps would be reconstructed with generally the same ramp configuration as the ramps for the existing interchange. A new reversible transit/HOV ramp would connect with the I-5 express lanes.	Similar to all options presented in the SDEIS. Instead of a lid over I-5 at Roanoke Street, the Preferred Alternative would include an enhanced bicycle/pedestrian path adjacent to the existing Roanoke Street Bridge.
Portage Bay Area	The Portage Bay Bridge would be replaced with a wider and, in some locations, higher structure with six travel lanes and a 14-foot wide westbound managed shoulder.	Similar in width to Options K and L, similar in operation to Option A. Shoulders are narrower than described in SDEIS (2-foot-wide inside shoulders, 8-foot-wide outside shoulder on eastbound lanes), posted speed would be reduced to 45 mph, and median plantings would be provided to create a boulevard-like design.
Montlake Area	The Montlake interchange would remain in a similar location as today. A new bascule bridge would be constructed over the Montlake Cut. A 1,400-foot-long lid would be constructed between Montlake Boulevard and the Lake Washington shoreline. The bridge would include direct-access ramps to and from the Eastside. Access would be provided to Lake Washington Boulevard via a new intersection at 24th Avenue East.	Interchange location similar to Option A. Lid would be approximately 75 feet longer than previously described for Option A, and would be a complete lid over top of the SR 520 main line, which would require ventilation and other fire, life, and safety systems. Transit connections would be provided on the lid to facilitate access between neighborhoods and the Eastside. Montlake Boulevard would be restriped for two general-purpose lanes and one HOV lane in each direction between SR 520 and the Montlake Cut.
West Approach Area	The west approach bridge would be replaced with wider and higher structures, maintaining a constant profile rising from the shoreline at Montlake out to the west transition span. Bridge structures would be compatible with potential future light rail through the corridor.	Bridge profile most similar to Option L and slightly steeper; structure types similar to Options A and L. The gap between the eastbound and westbound structures would be wider than previously described to accommodate light rail in the future.
Floating Bridge Area	A new floating span would be located approximately 190 feet north of the existing bridge at the west end and 160 feet north of the existing bridge at the east end. The floating bridge would be approximately 20 feet above the water surface at the midspan (about 10 to 12 feet higher than the existing bridge deck).	Similar to design described in the SDEIS. The bridge would be approximately 10 feet lower than described in the SDEIS, and most of the roadway deck support would be constructed of steel trusses instead of concrete columns.



Exhibit 4. Preferred Alternative and Comparison to SDEIS Options

Geographic Area	Preferred Alternative	Comparison to SDEIS Options A, K, and L
Eastside Transition Area	A new east approach to the floating bridge, and a new SR 520 roadway would be constructed between the floating bridge and Evergreen Point Road.	Same as described in the SDEIS.

The differences between the Preferred Alternative and the options presented in the SDEIS include:

- Reduced the lid over I-5 to a smaller bicycle/pedestrian undercrossing
- Designed the westbound shoulder on the Portage Bay Bridge to operate as a managed shoulder that would be used as an auxiliary lane during peak commute hours
- Reduced the posted speed to 45 miles per hour in the Seattle portion of the corridor and reduced the overall footprint by narrowing the shoulders
- Reconfigured Montlake Boulevard between SR 520 and the Montlake Cut to include transit/HOV lanes
- Increased the overall size and length of the lid located in the Montlake area
- Reconfigured the west approach bridges (eastbound and westbound structures) to have a wider gap between them
- Lowered the roadway height on the floating bridge

Seattle

As described in the SDEIS, SR 520 would connect to I-5 in a configuration similar to the way it connects today. Improvements to the I-5/SR 520 interchange would include a new reversible HOV ramp connecting the new SR 520 HOV lanes to existing I-5 reversible express lanes. The project would include an enhanced bicycle/pedestrian crossing spanning I-5 near Roanoke Street, and landscaped lids across SR 520 at 10th Avenue East and Delmar Drive East, and in the Montlake area to help reconnect the communities on either side of the roadway.

The new Portage Bay Bridge design under the Preferred Alternative would have two general-purpose lanes and an HOV lane in each direction, plus a managed westbound shoulder. In response to community interest and public comment on the SDEIS, the width of the new Portage Bay Bridge at the midpoint has been reduced, and a planted median would separate the eastbound and westbound travel lanes. The Preferred Alternative design of the Portage Bay Bridge would operate traffic at 45 miles per hour (mph) as a boulevard.

Under the Preferred Alternative, the SR 520 interchange with Montlake Boulevard would be similar to today's interchange, connecting to the University District via Montlake Boulevard and the Montlake bascule bridge. A new bascule bridge would be added to Montlake Boulevard NE, parallel



to the existing bridge, and Montlake Boulevard would be restriped and reconfigured between SR 520 and the Montlake Cut to include two general-purpose lanes and one HOV lane for improved transit connectivity. A large new lid would be provided over SR 520 in the Montlake area, configured for transit and bicycle/pedestrian connectivity. The lid would function as a vehicle crossing for eastbound SR 520 traffic exiting to Montlake Boulevard and Lake Washington Boulevard. The lid would also serve as a pedestrian crossing, a landscaped area, and open space. The Lake Washington Boulevard ramps and the Montlake Freeway Transit Station would be removed. Most transfers that currently take place at the freeway transit station would occur at the new multimodal transit station at Montlake Boulevard and NE Pacific Street.

The SR 520 roadway would maintain a constant slope profile rising from the east portal of the new Montlake lid, through Union Bay, across Foster Island, out to the west transition span of the Evergreen Point Bridge. This profile is most similar to the profile described in the SDEIS for Option L, but is slightly steeper for improved stormwater management.

Lake Washington

Floating Bridge

The alignment of the floating bridge is the same as evaluated in the SDEIS. The floating span would be located approximately 190 feet north of the existing bridge at the west end and 160 feet north at the east end.

The pontoon layout for the new 6-lane floating bridge is the same as evaluated in the SDEIS. The new floating bridge would be supported by 21 longitudinal pontoons, 2 cross pontoons, and 54 supplemental stability pontoons. As described in the SDEIS, the longitudinal pontoons would not be sized to carry future high-capacity transit (HCT), but would be equipped with connections for additional supplemental stability pontoons to support HCT in the future.

The new bridge would have two 11-foot-wide general-purpose lanes in each direction, one 12-foot-wide HOV lane in each direction, 4-foot-wide inside shoulders, and 10-foot-wide outside shoulders. As a result of comments on the SDEIS, the height of the bridge deck above the water has been lowered to reduce visual effects. At mid-span, the floating bridge would now rise approximately 20 feet above the water, compared to approximately 30 feet for the design described in the Draft EIS and SDEIS. The roadway would be about 10 feet higher than the existing bridge deck. At each end of the floating bridge, the roadway would be supported by rows of concrete columns. Steel trusses would support the remainder of the roadway across the pontoons.

Bridge Maintenance Facility

The new bridge maintenance facility would be as described in the SDEIS. Routine access, maintenance, monitoring, inspections, and emergency response for the floating bridge would be based out of a new bridge maintenance facility located underneath SR 520 between the east shore of Lake Washington and Evergreen Point Road in Medina. This bridge maintenance facility would



include a working dock, an approximately 7,200-square-foot maintenance building, and a parking area.

Eastside Transition Area

The SR 520, I-5 to Medina project and the SR 520, Medina to SR 202 project overlap between Evergreen Point Road and 92nd Avenue NE in Yarrow Point. Work planned as part of the SR 520, I-5 to Medina project between Evergreen Point Road and 92nd Avenue NE would include moving the Evergreen Point Road transit stop west to the lid (part of the SR 520, Medina to SR 202 project) at Evergreen Point Road, adding new lane and ramp striping from the Evergreen Point lid to 92nd Avenue NE, and moving and realigning traffic barriers for the new lane striping. The restriping would transition the SR 520, I-5 to Medina project improvements into the improvements completed as part of the SR 520, Medina to SR 202 project.

When will the project be built?

Construction for the SR 520, I-5 to Medina project is planned to begin in 2012, after project permits and approvals are received. In order to maintain traffic flow in the corridor, the project would be built in stages. Major construction in the corridor is expected to be complete in 2018. The most vulnerable structures (the floating portion of the Evergreen Point Bridge, its east and west approaches, and the Portage Bay Bridge) would be built in the first stages of construction, followed by the less vulnerable components (Montlake and I-5 interchanges). Exhibit 5 provides an overview of the anticipated construction stages and durations identified for the SR 520, I-5 to Medina project.

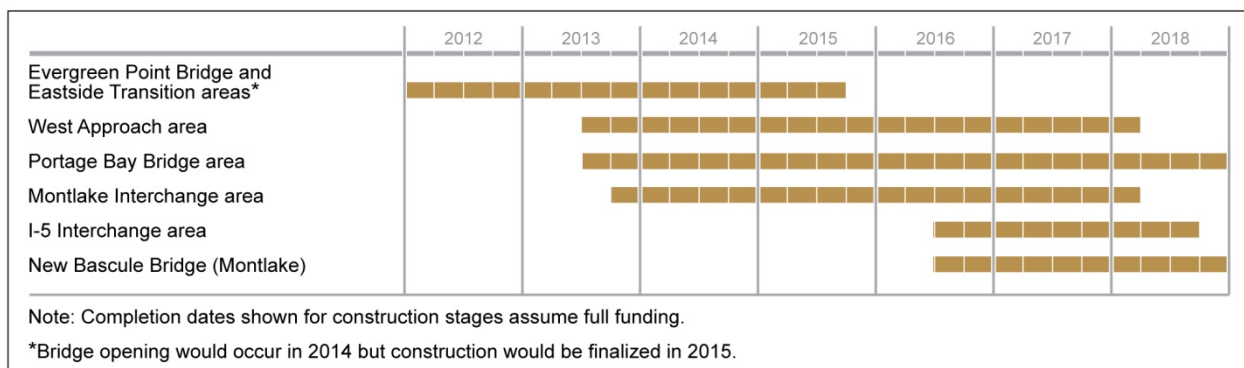

Exhibit 5. Preferred Alternative Construction Stages and Durations

A Phased Implementation scenario was discussed in the SDEIS as a possible delivery strategy to complete the SR 520, I-5 to Medina project in phases over an extended period FHWA and WSDOT continue to evaluate the possibility of phased construction of the corridor should full project funding not be available by 2012. Current committed funding is sufficient to construct the floating portion of the Evergreen Point Bridge, as well as the new east approach and a connection to the existing west approach. The Final EIS discusses the potential for the floating bridge and these east and west “landings” to be built as the first phase of the SR 520, I-5 to Medina project. This differs from the SDEIS Phased Implementation scenario, which included the west approach and the Portage



Bay Bridge in the first construction phase. Chapters 5.15 and 6.16 of the Final EIS summarize the effects for this construction phase. Therefore, this discipline report addendum addresses only the effects anticipated as a result of the updated construction schedule.

Are pontoons being constructed as part of this project?

WSDOT has completed planning and permitting for a new facility that will build and store the 33 pontoons needed to replace the existing capacity of the floating portion of the Evergreen Point Bridge in the event of a catastrophic failure. If the bridge does not fail before its planned replacement, WSDOT would use the 33 pontoons constructed and stored as part of the SR 520 Pontoon Construction Project in the SR 520, I-5 to Medina project. An additional 44 pontoons would be needed to complete the new 6-lane floating bridge planned for the SR 520, I-5 to Medina project. The additional pontoons would be constructed in a casting basin at the Concrete Technology Corporation in the Port of Tacoma and, if available, at the new pontoon construction facility located on the shores of Grays Harbor in Aberdeen, Washington. Final construction locations will be identified at the discretion of the contractor. For additional information about project construction schedules and pontoon construction, launch, and transport, please see the Construction Techniques and Activities Discipline Report Addendum and Errata (WSDOT 2011b).

Noise Analysis Overview

What is sound (noise)?

This section discusses how noise is evaluated—its definition, transmission characteristics, and measurement. This section also provides some typical noise levels for reference.

Sound is any change in air pressure that the human ear can detect, from barely perceptible sounds to sound levels that can cause hearing damage. These changes in air pressure are translated to sound in the human ear. The greater the change in air pressure, the louder the sound. For example, a quiet whisper in the library creates a relatively small change in the room air pressure, whereas air pressure changes are much greater in the front row of a rock concert.

In addition to the loudness of sound, *frequency* is a term also used to describe sound. The frequency of sound is determined by the number of recurring changes in air pressure per second. A sound that contains a relatively high number of pressure changes per second is generally referred to as a high frequency noise or “high-pitched.” One common example of a high-frequency noise is a referee’s whistle. A sound that has a low number of pressure changes per second is referred to as low frequency or low-pitched noise (for example, a bass drum).

A person’s response to noise is subjective and can vary greatly from person to person. Some key factors that can influence an individual’s response include the loudness, the frequency, the amount



of background noise present, and the nature of the activity that the noise affects. When sounds are perceived as unpleasant, unwanted, or disturbingly loud, they are normally considered “noise.”

How Sound is Measured

Sound is measured in terms of both loudness and frequency. The unit used to measure the loudness of sound is called a decibel (dB). In simple terms, the dB scale is a logarithmic conversion of air pressure level variations (measured in a unit called a Pascal) to a unit of measure with a more convenient numbering system. A person with average hearing can detect a wide range of sound pressures, a ratio of over a million to one. A direct application of the Pascal linear scale using sound pressures would require the use of numbers typically ranging from about 10 micro-Pascals to 100,000,000 micro-Pascals. The dB scale simplifies the units of sound measurement to a manageable range of numbers and is a more accurate representation of how the human ear reacts to variations in air pressure. A range from 0 to 120 dB is the typical range of hearing.

While the loudness of sound is an easy concept for most people, a sound’s frequency is just as important in understanding how to hear sounds. Frequency is measured in terms of the number of changes in air pressure that occur per second. The unit used to measure the frequency of sound is called a hertz.

Of course, discussing sounds in terms of both loudness and frequency can become tedious and confusing. In order to simplify matters, an adjustment is made to the dB measurement scale that, in addition to loudness, accounts for the human ear’s sensitivity to frequencies. The adjusted dB scale, referred to as the A-weighted dB scale, provides an accurate “single number” measure of what the human ear can actually hear. When the A-weighted dB scale is used, the dB levels are designated as dBA. This unit of measurement is used in this report.

For a sense of perspective, normal human conversation ranges between 44 and 65 dBA when people are about 3 to 6 feet apart. Very slight changes in noise levels, up or down, are generally not detectable by the human ear. The smallest change in noise level that a human ear can perceive is about 3 dBA, while changes of 5 dBA or more are clearly noticeable. For most people, a 10-dBA increase in sound levels is judged as a doubling of sound level, while a 10-dBA decrease in sound levels is perceived to be half as loud. For example, a person talking at 70 dBA is perceived as twice as loud as the same person talking at 60 dBA.

Because decibels are expressed on a logarithmic scale, they cannot be combined by simple addition. For example, if a single vehicle pass-by produces a sound level of 60 dB at 50 feet from a roadway, two identical vehicle pass-bys would not produce a sound level of 120 dB. In fact, they would produce a sound level of 63 dB. To combine decibels, they must first be converted to energy, then added or subtracted as appropriate and converted back to decibels.

Typical Neighborhood Noise Levels

In most neighborhoods, nighttime noise levels are noticeably lower than daytime noise levels. In a quiet rural area at night, noise levels from crickets or wind rustling leaves on the trees can range



between 32 and 35 dBA. As residents start their day and local traffic increases, the same rural area can have noise levels ranging from 50 to 60 dBA. Noise levels in urban neighborhoods are louder than rural areas. Noise levels during the day in a noisy urban area are frequently as high as 70 to 80 dBA. Nighttime noise levels in urban areas are generally much quieter than daytime noise levels and can range from 40 to 50 dBA.

Exhibit 6 shows some common noise sources or activities and compares their relative loudness to that of an 80-dBA source, such as a garbage disposal or food blender.

Noise Source or Activity	Sound Level (dBA)	Subjective Impression	Relative Loudness (human judgment of different sound levels)
Jet aircraft takeoff from carrier (50 feet)	140	Threshold of pain	64 times as loud
50-horsepower siren (100 feet)	130		32 times as loud
Loud rock concert near stage Jet takeoff (200 feet)	120	Uncomfortably loud	16 times as loud
Float plane takeoff (100 feet)	110		8 times as loud
Jet takeoff (2,000 feet)	100	Very loud	4 times as loud
Heavy truck or motorcycle (25 feet)	90		2 times as loud
Garbage disposal (2 feet) Pneumatic drill (50 feet)	80	Moderately loud	Reference loudness
Vacuum cleaner (10 feet) Passenger car at 65 mph (25 feet)	70		1/2 as loud
Typical office environment	60		1/4 as loud
Light auto traffic (100 feet)	50	Quiet	1/8 as loud
Bedroom or quiet living room Bird calls	40		1/16 as loud
Quiet library, soft whisper (15 feet)	30	Very quiet	
High quality recording studio	20		
Acoustic test chamber	10	Just audible	
	0	Threshold of hearing	

Source: Beranek 1988.

Exhibit 6. Sound Levels and Relative Loudness of Typical Noise Sources

How Noise Changes over Time

Noise levels from most sources tend to vary with time. For example, noise levels increase when a car approaches, then reach a maximum peak as it passes, and decrease as the car moves farther away. In this example, noise levels within a 1-minute timeframe may range from 45 dBA as the vehicle approaches, increase to 65 dBA as it passes by, and return to 45 dBA as it moves away.



To account for the variance in loudness over time, a common noise measurement is the equivalent sound level or L_{eq} . The L_{eq} is defined as the energy average noise level, in dBA, for a specific period (for example, 1 minute). Returning to the example of the passing car, assume that the energy average noise level was 60 dBA during the entire period of time the car could be heard as it passed by. In this example, the noise level would be stated as 60 dBA L_{eq} .

The equivalent sound level (L_{eq}) is used to account for the variance in loudness over time. Transportation-related noise is most often described in terms of L_{eq} .

How Noise Decreases over Distance

Several factors determine how sound levels decrease, or attenuate, over a distance. Two general categories apply to noise sources: a *point* source (for example, a church bell) and a *line* source (such as constant flowing traffic on a busy highway).

A single-point noise source will attenuate at a rate of 6 dB each time the distance from the source doubles. Thus, a point source that produces a noise level of 60 dB at a distance of 50 feet would attenuate to 54 dB at 100 feet and to 48 dB at 200 feet. A line source such as a highway, however, generally reduces at a rate of approximately 3 dB each time the distance doubles. Using the same example above, a line source measured at 60 dB at 50 feet would attenuate to 57 dB at 100 feet and to 54 dB at 200 feet.

Attenuation of point and line sources is influenced by the physical surroundings between the source and the receiver. For example, interactions of sound waves with the ground often result in slightly higher attenuation (called ground absorption effects) than the reduction factors given in the preceding paragraph. Other factors that affect the attenuation of sound with distance include existing structures, topography, dense foliage, ground cover, and atmospheric conditions (such as wind, temperature, and relative humidity). Details on the potential effects of these factors are listed in the 2009 Noise Discipline Report.

When is a noise study performed?

FHWA and WSDOT require a noise analysis on all Type I projects. Type I projects involve (1) the construction of a new highway on a new alignment, (2) significant horizontal or vertical changes to the current highway alignment, or (3) increases to the number of through traffic lanes on an existing highway. Both agencies consider the proposed project a Type I project from I-5 to Medina (west of Evergreen Point Road) due to an increase in the number of through-traffic lanes.

What were the methods used to evaluate the potential effects and how have they changed since publication of the SDEIS?

The potential effects of the Preferred Alternative were evaluated using the same methods used to evaluate the potential effects of the No Build Alternative and SDEIS options (see Noise Analysis Overview above and the 2009 Noise Discipline Report). The No Build Alternative was updated and



re-modeled using the latest traffic volumes, mixture, and speed data projection prepared by the project team. Modeling the No Build Alternative with the most recent traffic data projections ensures proper comparison with the Preferred Alternative projected traffic noise levels. The Preferred Alternative design differs from the SDEIS options, and the corresponding alignment configuration was modeled to ensure accurate projections of future traffic noise levels for the Preferred Alternative. The Preferred Alternative was also modeled with the most recent traffic data projections along with the most current design drawings. These design files included a full three-dimensional plan and profile of the proposed highway, ramps, retaining walls, and other design elements that could affect the transmission of noise. The team also used updated topographical maps for the surrounding areas and reviewed and verified all noise modeling locations.

To further assist the reader in navigating through this report, each of the following steps is used in the analysis:

1. Review all applicable federal, state, and local criteria for traffic noise analyses. These criteria provide approved methods, including the proper traffic noise model and noise abatement criteria for evaluating the project's potential effects. ➤ Step 1: *What criteria are used to evaluate potential effects?*
2. Establish the study area and perform field reconnaissance to identify noise-sensitive land uses (for example, parks) and local topography that affects the transmission of noise. ➤ Step 2: *What is the study area for the noise analysis?*
3. Select noise measurement locations that will best characterize the existing noise environment. Strategically selected noise monitoring locations help identify the overall traffic noise levels as well as identify other major noise sources in the study area. (Noise monitoring locations described in this report are only used for project data collection and noise modeling, and not for long-term study or monitoring.) ➤ Step 3: *Where are the sound measurement locations?*
4. Select the proper noise measurement equipment and adhere to methods that will meet or exceed the federal, state, or local measurement standards. In addition to noise monitoring, select proper equipment to collect traffic speed and volume data. ➤ Step 4: *What equipment and methods were used for the sound measurements?*
5. Perform onsite noise measurements to validate the Traffic Noise Model (TNM). Collect traffic volume and speed data and make note of all existing topography that affects the transmission of noise. ➤ Step 5: *What are the measured sound levels?*



- | | |
|--|--|
| 6. Develop the input to the TNM using the existing roadway alignments and counted traffic flow. Input the noise monitoring data to verify (or validate) that the TNM accurately predicts traffic noise levels at all monitoring locations. | ➤ Step 6: <i>Verification of Traffic Noise Model Predictions</i> |
| 7. Model existing SR 520, I-5 to Medina project corridor traffic noise levels using the peak-hour traffic volumes generated by the transportation discipline analysts and posted speed limits. | ➤ Step 7: <i>What are the existing peak-hour traffic noise levels?</i> |
| 8. Evaluate potential effects of construction-related noise for the Preferred Alternative. Calculate peak construction noise levels based on the equipment to be used, the distance from the construction zones to receivers, and the duration and time of the construction. | ➤ Step 8: <i>How would construction of the project affect noise levels?</i> |
| 9. Model future SR 520, I-5 to Medina project corridor traffic noise levels using the peak-hour traffic volumes generated by the transportation discipline analysts and posted speed limits. Future year 2030 conditions include the Preferred Alternative and the No Build Alternative. | ➤ Step 9: <i>How would operation of the project affect noise levels?</i> |
| 10. Compare the modeled noise-level results to the project traffic noise criteria to determine where noise abatement could be considered. | ➤ Step 10: <i>What has been done to avoid or minimize negative effects from noise?</i> |
| 11. Re-model the Preferred Alternative with options with noise abatement measures and verify that the noise abatement is both reasonable and feasible. | ➤ Step 11: <i>What has been done to avoid or minimize negative effects from noise?</i> |
| 12. Identify what noise abatement measures are recommended for traffic noise effects. | ➤ Step 12: <i>What has been done to avoid or minimize negative effects from noise? What noise walls are recommended for the Preferred Alternative? What other types of traffic noise abatement is WSDOT currently considering?</i> |

What project coordination was performed?

The noise discipline analysts worked directly with federal, state, and local agencies and with community groups to ensure the study area was adequately defined and all noise-sensitive properties were identified. The analysts coordinated with FHWA, WSDOT, Sound Transit, King County, the City of Seattle, the City of Medina, the Town of Hunts Point, the City of Clyde Hill, the Town of Yarrow Point, the City of Kirkland, and the City of Bellevue. The analysts also attended



several community meetings held throughout the SR 520, I-5 to Medina project corridor. The analysts solicited and received valuable input during these meetings, which was used to select the noise monitoring and modeling locations.

The noise analysts coordinated with WSDOT's Air Quality, Acoustics, and Energy Program for information related to the methods required for a noise study in Washington. The noise analysts worked with WSDOT personnel, project team members, and the public to identify all noise-sensitive land uses and to determine an acceptable method of analyzing the many parks and trails in the SR 520, I-5 to Medina project corridor to ensure that noise abatement would be considered. For a more detailed explanation of the methodology developed for this project, please see the "What equipment and methods were used for the sound measurements?" section.

The analysts also coordinated with project team leads to obtain the following information:

- **Project design drawings**—details on the project alignment and profiles.
- **Relocations**—information about displacement of public facilities, residents, or commercial uses.
- **Land use**—details on existing study area land use, including noise-sensitive receivers such as residences, motels, hotels, public meeting rooms, schools, churches, libraries, hospitals, auditoriums, and office space. The analysts also conducted research to identify where any substantial change in land use might be expected.
- **Transportation**—details on traffic data, including volumes, speeds, and vehicle types for all major roadways within the SR 520, I-5 to Medina project corridor.
- **Recreation, Section 4(f) of the U.S. Department of Transportation (USDOT) Act of 1966, and Section 6(f) of the Land and Water Conservation Fund Act of 1965 resources**—coordination with these discipline analysts about potential noise effects on parks and historic properties.

What criteria are used to evaluate potential effects?

FHWA has published traffic noise criteria that determine when noise abatement must be considered for a federally funded highway project. The following sections provide details on the FHWA and WSDOT criteria, guiding plans, and policies.

Federal Highway Administration

FHWA traffic noise criteria defined in 23 Code of Federal Regulations (CFR) 772 are compared to the study area traffic-noise levels. The criteria applicable for residences, churches, schools, recreational uses, and similar areas are an exterior hourly L_{eq} that approaches or exceeds 67 dBA. The criteria applicable for other developed lands (such as commercial and industrial uses) are an exterior L_{eq} that approaches or exceeds 72 dBA. FHWA also requires noise abatement to be considered if future noise levels are projected to result in a "substantial increase" over existing noise levels.



Washington State Department of Transportation

WSDOT's NAC further clarify the FHWA traffic noise criteria. WSDOT clarifies the meaning of "approaches" by requiring noise abatement to be considered when predicted project-related noise levels approach the FHWA criteria level within 1 dBA. Therefore, noise abatement must be considered for residential land use with projected noise levels of 66 dBA L_{eq} or higher and for commercial land uses with noise levels of 71 dBA L_{eq} or higher. Exhibit 7 provides FHWA and WSDOT's NAC table, which identifies noise levels in L_{eq} that are considered an effect on various land use activity categories. If a noise effect is identified as part of this Type I project, further analysis of potential noise abatement shall be studied following procedures outlined in WSDOT's *Environmental Procedures Manual, Highway Traffic Noise Analysis and Abatement* (WSDOT 2008).

FHWA's use of the terms **approaches** and **substantial increase** leaves room for interpretation by the State of Washington.

WSDOT defines **approaches** as within 1 dBA of the FHWA criteria and **substantial increase** as 10 dBA.

Exhibit 7. FHWA and WSDOT Noise Abatement Criteria Table

FHWA Activity Category	FHWA Criteria in L_{eq} (h) (dBA)	WSDOT Traffic Noise Abatement Criteria L_{eq} (h) (dBA)	Description of Activity
A	57 (exterior)	56 (exterior)	Lands on which serenity and quiet are of extraordinary significance and serve an important public need and where the preservation of those qualities is essential if the area is to continue to serve its intended purpose.
B	67 (exterior)	66 (exterior)	Picnic areas, recreation areas, playgrounds, active sports areas, parks residences, motels, hotels, schools, churches, libraries, and hospitals. ^{a,b}
C	72 (exterior)	71 (exterior)	Developed lands, properties or activities not included in Categories A or B above.
D	–	–	Undeveloped lands.
E	52 (interior)	51 (interior)	Residences, motels, hotels, public meeting rooms, schools, churches, libraries, hospitals, and auditoriums. ^c

L_{eq} (h) = hourly equivalent sound level.

^a Bicycle and pedestrian facilities that serve a transportation purpose and qualify as a transportation facility will not be evaluated for noise effects or abatement.

^b Activity Category B also includes campgrounds, RV parks, and cemeteries.

^c Interior noise abatement will only be considered for public institutions such as schools, hospitals, and libraries and analysis of exterior sound abatement is determined to be unreasonable or infeasible.

Source: WSDOT 2008.

WSDOT also clarifies the meaning of "substantial increase" by considering 10 dBA to be a substantial increase.



Noise levels of 80 dBA L_{eq} and higher for outdoor activity areas are defined as “a severe exceedance of the NAC.” An NAC exceedance is also considered severe if future design-year noise levels are predicted to increase by 30 dBA or higher over existing noise levels.

There are no criteria for undeveloped lands or construction noise.

This discipline report uses the WSDOT NAC, which FHWA have approved for use on highway projects in Washington.

Guiding Plans and Policies

The noise discipline analysts reviewed the following plans and policies as part of the noise effects criteria analysis:

- Federal Transit Administration, Transit Noise and Vibration Impact Assessment Manual, 1995
- King County Code (KCC), Chapter 12.88, Environmental Sound Levels, as amended by Ordinance 14114, 2001
- Medina Municipal Code, Title 8 Health and Safety, Chapter 8.06 Noise, 2001
- Seattle Municipal Code, Chapter 25.08, Noise Control, 2009
- USDOT, 23 CFR 772, Procedures for Abatement of Highway Traffic Noise and Construction Noise, 1996
- USDOT, FHWA Measurement of Highway-Related Noise, 1996
- USDOT, FHWA Highway Construction Noise: Measurement, Prediction and Mitigation, 1997
- USDOT, FHWA Traffic Noise Model, Version 2.5, 2004
- Washington Administrative Code (WAC) Chapter 173-60, Maximum Environmental Noise Levels, 1994
- WSDOT, *Environmental Procedures Manual, Highway Traffic Noise Analysis and Abatement*, Section 446, October 2008
- WSDOT, Traffic Noise Analysis and Abatement Policy and Procedures, March 17, 2006

Affected Environment

What were the updates to the affected environment?

The “Affected Environment” section of the Noise Discipline Report provides a detailed description of the affected environment. Although there were no updates to measured noise levels since preparation of the SDEIS analysis, there are several changes to the noise modeling locations on the



eastside of Lake Washington. Between the Evergreen Point Road lid and Lake Washington, several homes were relocated during early property acquisition. Because of these relocations, noise modeling locations were revised to better represent the remaining homes in the area. A summary of the updated affected environment is provided below.

The FHWA noise standard, which is documented in 23 CFR 772, requires the identification of all existing activities, developed lands, and undeveloped lands for which development is planned, designed, and programmed that noise from the project might affect. As defined in the WSDOT's *Environmental Procedures Manual, Highway Traffic Noise Analysis and Abatement* (WSDOT 2008), the noise study area that may be affected by noise from the project includes all lands within 500 feet of the project.

The noise discipline analysts performed a detailed reconnaissance of the project vicinity to identify all noise-sensitive properties within 500 feet of the SR 520, I-5 to Medina project. The study area includes both sides of SR 520 and the Seattle neighborhoods of Portage Bay, Roanoke, North Capitol Hill, Montlake, University of Washington, Washington Park Arboretum, Madison Park, Laurelhurst, and Medina. The analysts used physical features such as terrain and ground cover, along with any potential features that could be altered during construction, in the analysis.

It is possible that some roadways farther than 500 feet from the SR 520, I-5 to Medina project could experience increases in traffic volumes and noise under the proposed action. Under WSDOT policy, any additional roadways that are modified as part of the project are subject to the same level of noise analysis as SR 520. For those roadways where no modifications are proposed, no noise abatement analysis was performed.

At the request of concerned citizens, some areas outside the normal 500-foot range are included in this analysis. These areas include seven locations in the Laurelhurst neighborhood. These same locations were also analyzed in previous environmental noise studies for the SR 520 corridor. This noise report addresses areas from I-5 to the west side of Evergreen Point Road. Areas east of Evergreen Point Road are addressed in the SR 520 Medina to SR 202 project.

How do other local projects affect the results of this study?

Several other projects are currently under consideration in the greater Puget Sound area that might affect traffic volumes and, therefore, noise levels in the SR 520, I-5 to Medina project corridor. Because the transportation model considers these projects, they are included in this noise analysis. Please see the Final Transportation Discipline Report (WSDOT 2011c) for more information about these projects.



What are the existing sound characteristics of the study area?

This section provides an overview of the characteristics and land use in the SR 520, I-5 to Medina project corridor as it relates to the noise analysis. Land use is an important factor because it determines what criteria level is used for noise abatement. For noise studies, the actual use of the property determines the abatement criteria not the land use zone. For example, a residential land use in a commercial or industrial zone is analyzed using the residential NAC, not the less stringent commercial or industrial criteria.

Land Use

Land use in the SR 520, I-5 to Medina project corridor is primarily residential, with some schools, commercial uses, parklands, and undeveloped use scattered along the corridor.

- **Portage Bay/Roanoke.** The Portage Bay/Roanoke neighborhood is primarily single-family residential and includes a park and a church. Closer to Portage Bay, there are several multifamily land uses, along with some limited commercial uses such as restaurants and retail outlets. Several houseboats are located in the Portage Bay waterfront area along Boyer Avenue East.
- **North Capitol Hill.** The North Capitol Hill area includes residential and some light commercial uses such as retail and restaurants. Seattle Preparatory School and several parkland areas are also located in this area.
- **Montlake.** The Montlake neighborhood is mainly residential with some commercial uses such as retail stores and restaurants. This area also has parklands, a community center, playfields, the Museum of History and Industry, and the National Oceanic and Atmospheric Administration (NOAA) Northwest Fisheries Science Center (NWFSC) building.
- **Foster Island.** Foster Island is parkland with pedestrian trails.
- **Laurelhurst.** The Laurelhurst neighborhood north of SR 520 across Union Bay is entirely residential and faces the Evergreen Point Bridge.
- **Madison Park.** Madison Park is primarily residential, with a large multifamily complex located along the shore of Lake Washington facing SR 520. There are also several condominiums and single-family residential uses in the area. Commercial uses, such as retail stores and restaurants, are located farther from the lakeshore.
- **Lake Washington.** There are no permanent noise-sensitive land uses in Lake Washington.
- **Medina.** The Medina neighborhood is entirely residential.

As noted previously, the study area should include all lands within 500 feet of the project. At the request of community leaders, some locations considered in this analysis are greater than 500 feet



from the project, as WSDOT typically defines the study area. The analysts performed a detailed reconnaissance of the study area to identify all noise-sensitive properties that are, or could be, directly affected by the SR 520, I-5 to Medina project. All noise-sensitive properties included in this analysis are located on the north and south sides of the SR 520, I-5 to Medina project corridor, as listed below.

- **Portage Bay/Roanoke.** North of SR 520 from I-5 to Portage Bay
- **North Capitol Hill.** South of SR 520 from I-5 to Boyer Avenue East
- **Montlake North.** North of SR 520 between Portage Bay and East Montlake Park
- **Montlake South.** South of SR 520 between Boyer Avenue East and Lake Washington Boulevard East
- **University of Washington/Husky Stadium.** North of SR 520 within University of Washington Campus
- **Arboretum.** North and south of SR 520 within Washington Park Arboretum
- **Madison Park.** South of SR 520 between Washington Park Arboretum and Lake Washington
- **Laurelhurst.** North of SR 520 within the Webster Point neighborhood along Washington Park Arboretum
- **Medina North.** North of SR 520 between east bridge approach and Evergreen Point Road
- **Medina South.** South of SR 520 between east bridge approach and Evergreen Point Road

Exhibit 8 shows these 10 general neighborhood areas, which are used to organize the large amount of data that was generated in this analysis. For more information on current land uses in the study area, see the Land Use, Economics, and Relocations Discipline Report (WSDOT 2009b).

Topography

As described previously, the transmission of sound over distance can vary greatly depending on the topographical characteristics between the noise source and receiver. This section provides an overview of the topographical conditions as they relate to the transmission of noise in the SR 520, I-5 to Medina project corridor.

Seattle contains a large variety of topographical features that affect the transmission of noise.

- **Portage Bay/Roanoke.** Near the I-5/SR 520 interchange, both SR 520 and I-5 are at a lower elevation than the residential structures in the Portage Bay/Roanoke neighborhood. A new set of noise walls was constructed along the west side of I-5 and along Harvard Avenue on the east side of I-5. The hillside along the north side of SR 520, east of the I-5 interchange, also provides some noise reduction for the Portage Bay/Roanoke neighborhood.



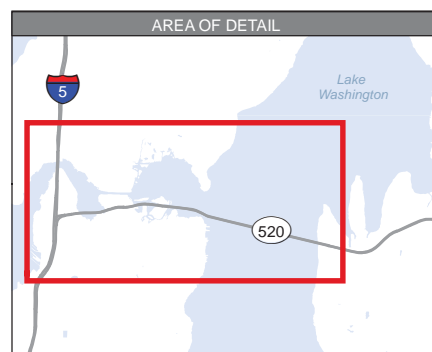
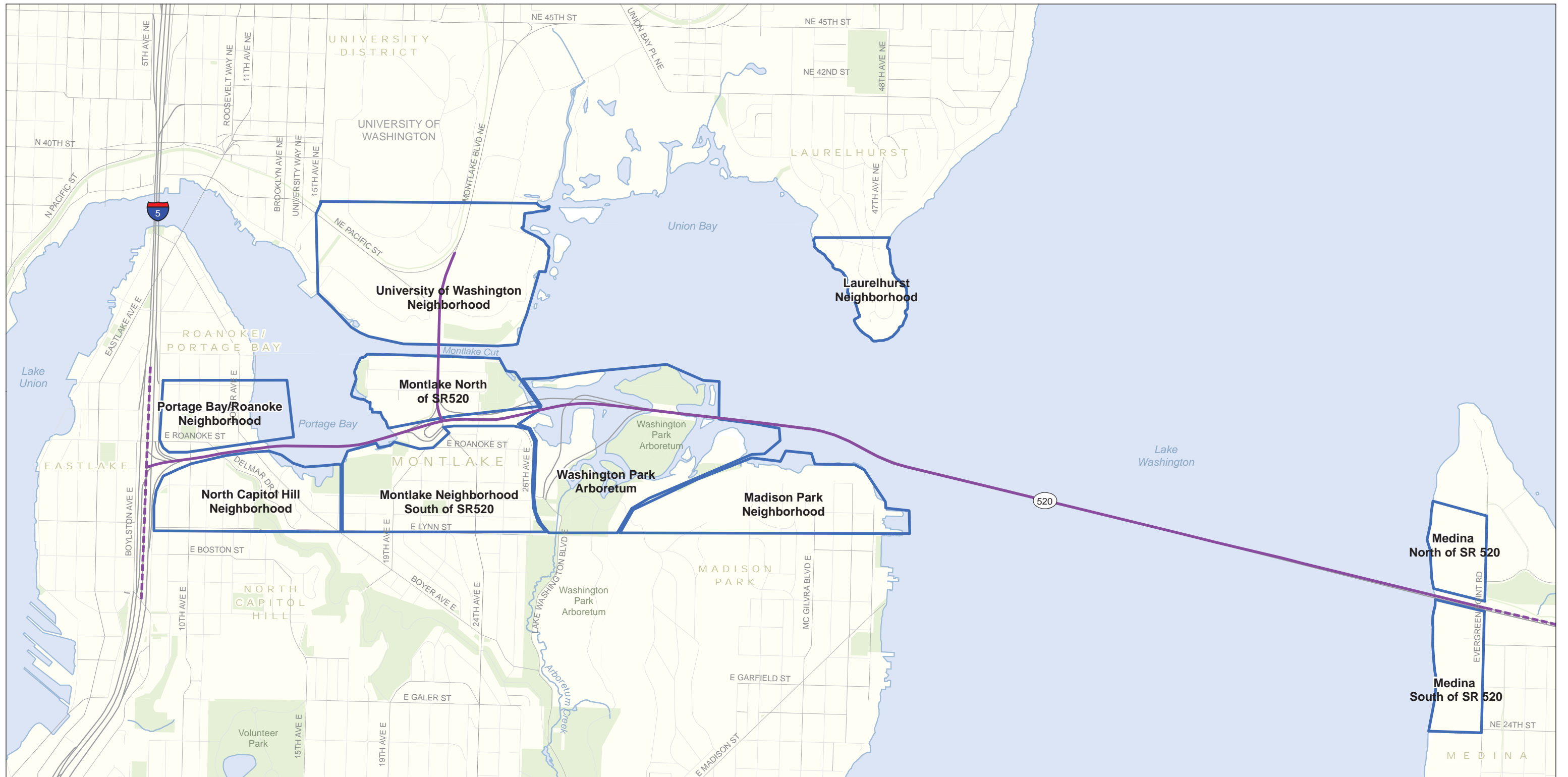

- Project Extent
- - - Denotes Limited or Optional Improvement
- Noise Analysis Area
- Park

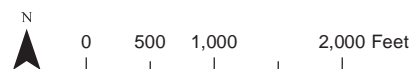

Source: King County (2005) GIS Data (Streams and Streets), King County (2007) GIS Data (Water Bodies), CH2M HILL (2008) GIS Data (Park). Horizontal datum for all layers is NAD83(91); vertical datum for layers is NAVD88.



Exhibit 8. Neighborhood Designations Used in Analysis (Update to Exhibit 11 of the 2009 Discipline Report)

I-5 to Medina: Bridge Replacement and HOV Project

In the eastern end of the Portage Bay/Roanoke area, the ground slopes down to the waterfront area along Boyer Avenue East. Because SR 520 is on a structure near this area (the Portage Bay Bridge), the highway is on the same grade or above the grade of many homes along Boyer Avenue East and nearby areas. Traffic on the Portage Bay Bridge can be heard at greater distances because the residents have a direct line-of-sight view of the SR 520 structure and have no shielding from existing buildings or other topography.

- **North Capitol Hill.** The North Capitol Hill neighborhood is also located above the existing grade of SR 520 in this area. Most receivers in the central and western section of North Capitol Hill have some shielding from SR 520, either from the existing hillside or from other structures. Homes on the eastern end of North Capitol Hill, where the hillside slopes down toward the Portage Bay Bridge, likely experience minimal noise reduction from topographical shielding. Many residents along 13th Avenue East, Boyer Avenue East, and Delmar Drive East have a line-of-sight view of the Portage Bay Bridge and, therefore, have little or no topographical shielding from traffic noise on the bridge.
- **Montlake.** Through Montlake, the roadway is at or near the grade of the surrounding residential areas. SR 520 is depressed at the Montlake Boulevard bridge over SR 520; however, noise reduction from the highway depression is minimal because the gradual ground slope allows noise to travel up the hillside with little reduction and because many receiver locations are close to SR 520.
- **Arboretum, Madison Park, and Laurelhurst.** No substantial noise-reducing topographical features buffer noise from the bridge over Foster Island and north of the Madison Park neighborhood. The Laurelhurst neighborhood is located across Union Bay to the north of the west approach to the Evergreen Point Bridge. The existing highway is approximately 1,500 feet from Webster Point, and residents in this area have a direct line-of-sight to SR 520.
- **Lake Washington.** There are no permanent, noise-sensitive receivers or topographical features, except water, to affect the transmission of noise across Lake Washington. Water acts as an acoustically hard surface and provides less attenuation from absorption than softer ground types like field grass. The effects of increased sound propagation over water were included in the study.
- **Medina.** The Medina neighborhood is relatively level near Evergreen Point Road, with a downward slope toward Lake Washington. The residents on the north side of SR 520 are either at or slightly above the highway grade, and residents on the south side of SR 520 are either at or slightly below the highway grade. Residences near the water are all below the existing and proposed highway elevation because of the eastern transition span. In addition, due to the relocation of several structures north of SR 520, the noise analysis locations and shielding from structures was re-evaluated for the Final EIS noise study.



Why are the sound measurements conducted?

Sound level measurements are recorded only to validate the TNM (see the “Verification of Traffic Noise Model Predictions” section). The sound level measurements are not used to establish the existing sound levels in the study area. Once the model is validated with the sound measurement data, the existing sound levels are established by modeling peak-hour traffic volumes (see the “What are the existing peak-hour traffic noise levels?” section).

Where are the sound measurement locations?

The noise discipline analysts collected a variety of information to help select sound measurement locations. The analysts studied aerial mapping, survey data, computer-aided design drawings, and information from the land use analysis, with special attention given to residential areas and the location of SR 520 and other major connector and arterial roads. Based on that research, the analysts selected the general areas for sound monitoring. They then collected more detailed information during onsite visits to the study area. The final selection of specific sound monitoring locations was made through a joint effort between the noise discipline analysts, WSDOT, Sound Transit, and the neighborhood communities and groups. The noise discipline analysts then measured sound levels at the 48 agreed-upon locations in the study area.

What methods were used for the sound measurements?

All noise level measurements were taken using the procedures for traffic noise measurements provided by the FHWA and WSDOT. The measurement locations were at least 5 to 10 feet from any solid structure to prevent acoustical reflections and at a height of 5 feet off the ground. The equipment used for noise monitoring included Bruel & Kjaer and Larson Davis sound level meters. All meters were calibrated before and after the measurement periods using a Bruel & Kjaer or Larson Davis sound level calibrator. Complete system calibration for all meters is performed annually by Bruel & Kjaer Instruments or another accredited testing laboratory. Calibration is traceable to the National Institute of Standards and Testing (NIST). All sound level meters met or exceeded the requirements for an American National Standards Institute (ANSI) Type 1 or Type 2 noise measurement system. Measurements were taken during free flowing traffic during normal weekday hours.

What methods were used for the noise modeling?

Traffic noise levels were calculated using the latest FHWA-approved noise model, Traffic Noise Model, Version 2.5, which was released in April 2004. Input to the model includes traffic volumes generated by the transportation discipline analysts and posted speeds. The sound-reducing effects of existing structures bordering the SR 520, I-5 to Medina project were taken into account.



Where are the noise modeling locations?

Under the Final EIS traffic noise analysis, sound levels were modeled at 230 locations in the SR 520, I-5 to Medina project corridor, representing 838 residences and residential equivalents. This is in comparison to 211 modeling locations representing 862 residences and residential equivalents used in the SDEIS. The change in modeling locations and residences are due to relocated homes in Medina, more accurate counts of multifamily units, and revised residential equivalents numbers.

Traffic noise modeling was performed to determine what locations in the study area approached or exceeded the NAC. Therefore, peak-hour traffic noise levels were calculated for existing conditions using current traffic volumes and for the future No Build Alternative and the Preferred Alternative using predicted year 2030 traffic volumes, with and without noise abatement measures and noise reducing design elements.

The noise receiver locations were carefully selected to ensure that all potentially affected areas were studied. The noise discipline analysts selected the 230 receivers in the study area based on aerial mapping and onsite visits. The 230 receivers represent approximately 838 residences and residential equivalents within the study area. As stated before, the numbers of residential equivalents are presented as whole numbers, and therefore, addition of residences and residential equivalents by segment, will be slightly different than summing all residences residential equivalents over the whole corridor. See the “What are the key points of this addendum?” under the “Introduction” for detailed information.

To help consolidate the large volume of data, the analysts selected TNM number designations that would correspond to the 10 neighborhood areas (see “Land Use” under the “What are the existing sound characteristics of the study area?” section). Exhibit 8 shows how the neighborhoods were grouped into receiver designation areas.

The analysts numbered noise modeling locations in each neighborhood for easy and consistent identification. For example, HR-4 is a modeling receiver number in the Portage Bay/Roanoke neighborhood. As shown later in this report, all modeling receivers with an “HR” designation represent the modeled receivers used in the Portage Bay/Roanoke neighborhood. The analysts assigned similar modeling receiver designations (BH, CH, MN, MS, UW, AB, MP, LH, PN [LPA], and PS [LPA]) for the other areas within the study area. The floating homes in Portage Bay represented by “BH” are grouped with the “HR” Portage Bay/Roanoke receivers in the data presented throughout the rest of this report. Previously in the Draft EIS report, the Medina area receivers north and south of SR 520 were designated PN and PS. When this report was prepared, several homes in the Medina area have been removed in preparation for the

Modeled Receiver Designations & Number of Residences and Residential Equivalents

HR—Portage Bay/Roanoke	(74)
BH—Floating Homes in Portage Bay	(9)
CH—North Capitol Hill	(219)
MN—Montlake north of SR 520	(106)
MS—Montlake south of SR 520	(142)
UW—University of Washington	(83)
AB—Washington Park Arboretum	(54)
MP—Madison Park	(99)
LH—Laurelhurst	(15)
PN (LPA)—Medina north of SR 520	(19)
PS (LPA)—Medina south of SR 520	(18)



project construction. The Medina area was re-evaluated and new modeling locations were selected for this analysis. To differentiate from the previous Draft EIS modeling locations, the Medina locations in this report are designated using PN (LPA) and PS (LPA).

Verification of Traffic Noise Model Predictions

Prior to using the TNM to predict noise levels in the SR 520, I-5 to Medina project corridor, the noise discipline analysts verified that the model was computing accurate noise levels. This is called model validation. The analysts used existing roadway alignments and the traffic counts and speed data observed during their monitoring sessions as input into the TNM. Major topographical features that affect the transmission of noise (for example, hills or high retaining walls) were also used as input.

Next, the analysts ran the TNM and compared the modeled noise levels with the measured noise levels. If the modeled and measured results agreed within ± 2 dBA, the model was considered accurate and met WSDOT requirements. A 2-dBA tolerance was used because a person with average hearing would need at least a 3-dBA change in noise level to notice a difference in overall loudness.

For locations where the modeled results differed by more than ± 2 dBA from the measured results, the analysts considered several corrective options:

- Identify and add missing terrain, trees, or ground zones to make sure that the model accurately represented the existing conditions in the area.
- Apply a correction factor in the TNM to manually adjust the noise levels to within the ± 2 -dBA tolerance (this is used only in rare cases where reflections or other acoustical anomalies exist).
- Identify and document the reason for the discrepancy (for example, non-traffic-related noise sources such as construction noise that occurred during the measurement period, thus causing the measured level to be higher than the calculated noise levels).

The analysts compared the measured with the modeled sound levels at all locations in the SR 520, I-5 to Medina project corridor. With a few exceptions, all locations were within the ± 2 -dBA validation requirement. The few exceptions were due to other non-traffic-related sound sources. Because observed traffic volumes and speeds were used for the model validation, modeled values may differ from the typical current peak-hour noise modeling values described later in this report. Attachment 5 includes a full listing of the TNM verification results for the projected study area.

What are the existing peak-hour traffic noise levels?

After the TNM is verified to accurately predict traffic sound levels, the next step in a traffic noise study is to model the existing peak-hour traffic noise levels. Existing peak-hour traffic noise levels (using posted speeds) represent the worst-case noise levels that can be expected under the current roadway alignment and traffic flow conditions. Existing peak-hour traffic noise levels were modeled using posted speeds and 2004 peak-hour traffic volumes generated by the transportation discipline analysts. The 2004 volumes were used because the difference between the 2004 and 2008 traffic



volumes is so small (less than 10 percent in most cases) that there would not be any measureable difference between the predicted noise levels for each traffic data set.

Existing peak-hour traffic noise levels were modeled with 230 receivers located throughout the study area. The analysts carefully selected the receiver locations to ensure that all potentially affected areas would be studied.

Existing peak-hour traffic noise levels were modeled for 230 receiver locations, representing 838 residences within the SR 520, I-5 to Medina project corridor. Noise levels at 270 residences approach or exceed the WSDOT NAC of 67 dBA L_{eq} . As previously described, the number of locations analyzed and results are slightly different from the SDEIS due to revised modeling locations in the Medina area resulting from WSDOT early property acquisitions. These results are summarized by neighborhood in the “Potential Effects of the Project Alternatives on Neighborhoods in the Study Area” section of this report.

Potential Effects

The 2009 Noise Discipline Report provides a detailed discussion of effects of the No Build Alternative and the SDEIS options (see pages 53 through 107). The discussion below supplements the 2009 Noise Discipline Report and discloses the effects of the Preferred Alternative, comparing it with the SDEIS options using new text and new or updated exhibits where appropriate.

How would construction of the project affect noise levels?

The noise discipline analysts predicted construction noise levels using the methods described in *FHWA Highway Construction Noise: Measurement, Prediction and Mitigation* (USDOT 1997). In addition to these FHWA methods, the analysts relied on their experience and work on major construction projects to assist in providing the most accurate information available. Information provided includes descriptions of the types of construction activities required for this type of project, noise levels associated with specific construction equipment, and overall construction-related noise and vibration projections.



Front End Loader

This section discusses the regulations and criteria governing construction noise, the methods of calculating construction noise levels, and the estimated worst-case noise levels for project construction. This section also introduces construction-related vibration and information on how vibration from construction projects affects humans and structures.



Construction activities could also affect wildlife and habitat, including fish and aquatic habitat. See the Ecosystems Discipline Report (WSDOT 2009c) for more details on the potential effects on wildlife and habitat.

Construction Noise Regulations

Project construction would take place within King County and the communities of Seattle and Medina. Most cities in Washington rely on WAC, Chapter 173-60, Maximum Environmental Noise Levels, for their noise ordinances. The WAC would apply to this project.

Seattle has adopted noise regulations that apply to construction activities as codified in the Seattle Municipal Code, Chapter 25.08, Noise Control.

The City of Medina has adopted regulations that limit construction and development activity as codified in the Medina Municipal Code, Chapter 8.06, Noise, and more specifically, Chapter 8.06.030, Limitations on Construction and Development Activity. The Medina Municipal Code has adopted portions of the King County Code by reference (KCC Chapters 12.86 through 12.100).

Because these regulations are subject to change, the most current versions must be used at the time construction commences within each community. WSDOT would be required to adhere to the construction noise regulations and obtain any site-specific requests for variances or other construction-related noise issues associated with the proposed project.

The following sections describe, in general, the construction noise regulations that apply to this project at the time this report was prepared. Each applicable code should be reviewed prior to the start of construction to assure that all requirements are met.

Washington Administrative Code

Daytime construction noise is exempt from regulations in the WAC. Therefore, within the WAC noise ordinance, project construction could be performed during the normal daytime hours of 7:00 a.m. to 10:00 p.m. If construction were to be performed during nighttime hours, WSDOT would be required either to meet the noise-level requirements presented in Exhibit 9 or to obtain a noise variance from the governing jurisdiction.

Exhibit 9. Washington State Noise Control Regulation

Source of Noise	Receiver of Noise (Maximum Allowable Sound Level in dBA) ^a		
	Residential	Commercial	Industrial
Residential	55	57	60
Commercial	57	60	65
Industrial	60	65	70

^a Between 10:00 p.m. and 7:00 a.m., the levels given above are reduced by 10 dBA for residential receiving property.



In addition to the property-line noise standards listed in Exhibit 9, there are exemptions for short-term noise exceedances, including those outlined in Exhibit 10, that are based on the minutes per hour that the noise limit is exceeded. This exhibit also provides the corresponding statistical descriptors for each range of exceedances.

The sound level descriptor L_{xx} used in Exhibit 10 is defined as the sound level exceeded xx percent of the time. To assist with compliance to the WAC, the statistical L_{xx} noise descriptor is very useful. For example, during a 1-hour measurement, an L_{25} of 75 dBA means the sound level was at or above 75 dBA for 15 minutes of that hour (25 percent of the time), which could be used to verify the 15-minute allowable exceedance criterion in the State's code. Similarly, two other statistical descriptors, the $L_{8.3}$ and $L_{2.5}$, can be used to verify the 5-minute and the 1.5-minute allowable exceedance criteria in the State's code.

Exhibit 10. Washington State – Exemptions for Short-Term Noise Exceedances

Statistical Descriptor ^a	Minutes Per Hour	Adjustment to Maximum Sound Level
L_{25}	15 (25% of one hour)	+5 dBA
$L_{8.3}$	5 (8.3% of one hour)	+10 dBA
$L_{2.5}$	1.5 (2.5% of one hour)	+15 dBA

^a L_{25} , $L_{8.3}$, and $L_{2.5}$ are the noise levels that are exceeded 25 percent, 8.3 percent, and 2.5 percent of the time (one hour, in this case).

Seattle Municipal Code

The City of Seattle has developed a set of construction-specific allowable noise-level limits that would apply to construction of the SR 520, I-5 to Medina project within the Seattle City limits. Unlike the WAC, the Seattle Municipal Code does not exempt daytime construction activities from regulation. WSDOT is coordinating with the City of Seattle and will obtain variances as needed. Exhibit 11 includes the maximum permissible sound levels depending on the district designations of the sound source and receiving properties.

Exhibit 11. City of Seattle – Maximum Permissible Sound Levels

District of Sound Source	District of Receiving Property within the City of Seattle (dBA) ^a		
	Residential (dBA)	Commercial (dBA)	Industrial (dBA)
Rural	52	55	57
Residential	55	57	60
Commercial	57	60	65
Industrial	60	65	70

^a Applies to daytime hours of 7:00 a.m. to 10:00 p.m.



The City of Seattle noise-level limits listed in Exhibit 11 are reduced or increased as follows:

1. Between 10:00 p.m. and 7:00 a.m. during weekdays and between 10:00 p.m. and 9:00 a.m. on weekends, the levels are reduced by 10 dBA for residential receiving property.
2. For any source of sound that is periodic, has a pure tone component, or is not measured with an impulse sound level meter, the levels are reduced by 5 dBA. Electrical substations are exempt from this penalty.
3. For any source of sound that is of short duration, the levels are increased as shown in Exhibit 12.

Exhibit 12. City of Seattle – Exemptions for Short-Term Noise Exceedances

Statistical Descriptor ^a	Minutes Per Hour	Adjustment to Maximum Sound Level
L ₂₅	15 (25% of one hour)	+5 dBA
L _{8.3}	5 (8.3% of one hour)	+10 dBA
L _{2.5}	1.5 (2.5% of one hour)	+15 dBA

^a L₂₅, L_{8.3}, and L_{2.5} are the noise levels that are exceeded 25 percent, 8.3 percent, and 2.5 percent of the time (one hour, in this case).

At the time this report was written, the short-term allowable exceedances in Exhibit 12 are the same as those provided in the WAC (see Exhibit 10).

The Seattle Municipal Code, Chapter 25.08.425, applies directly to construction and equipment operations. For the purposes of enforcement, the maximum permissible sound levels listed in Exhibit 11 and the time-restrictive limits in Exhibit 12 are to be measured from the real property of another person or at a distance of 50 feet from the equipment, whichever is greater.

The levels in Exhibit 11 may be exceeded between 7:00 a.m. and 10:00 p.m. on weekdays and between 9:00 a.m. and 10:00 p.m. on weekends by no more than the amounts shown in Exhibit 13.

Exhibit 13. City of Seattle – Allowable Exceedances for Construction and Equipment Operations

Allowable Exceedance	Equipment Covered
25 dBA	Equipment on construction sites, including but not limited to crawlers, tractors, dozers, rotary drill and augers, loaders, power shovels, cranes, derricks, graders, off-highway trucks, ditchers, trenchers, compactors, compressors, and pneumatic-powered equipment
20 dBA	Portable powered equipment used for temporary locations in support of construction activities or used in the maintenance of public facilities, including but not limited to chainsaws, log chippers, lawn and garden equipment, and powered hand tools
15 dBA	Powered equipment used in temporary repair or periodic maintenance of the grounds and appurtenances of residential property, including but not limited to lawnmowers, powered hand tools, snow removal equipment, and composters



Sounds created by impact types of construction equipment (including but not limited to pavement breakers, pile drivers, jackhammers, sandblasting tools, or other types of equipment or devices that create impulse noise or impact noise or are used as impact equipment), as measured at the property line or 50 feet from the equipment, whichever is greater, may exceed the noise-level limits given in Exhibit 11 in any 1-hour period between 8:00 a.m. and 5:00 p.m. on weekdays and 9:00 a.m. and 5:00 p.m. on weekends by no more than the maximum noise levels shown in Exhibit 14.

Exhibit 14. City of Seattle – Maximum Noise Levels for Impact Types of Construction Equipment

Statistical Descriptor ^a	Noise Level (in dBA)	Time Duration Exceedance Prohibited
L _{eq}	90	Continuously
L ₅₀	93	30 minutes
L ₂₅	96	15 minutes
L _{12.5}	99	7.5 minutes ^b

^a Leq, L₅₀, L₂₅, and L_{12.5} are the equivalent sound level and the noise levels that are exceeded 50 percent, 25 percent, and 12.5 percent of the time.

^b Provided that sounds levels in excess of 99 dBA are prohibited unless authorized by variance obtained from the Administrator and provided further that sources producing sound levels less than 90 dBA shall comply with the provisions (A) and (B) as follows:

(A) The standard of measurement shall be a 1 hour Leq. Leq may be measured for times not less than 1 minute to project hourly Leq. Reference to 1 hour is for measurement purposes only and will be construed as limiting construction to a 1-hour period.

(B) These provisions will be reviewed periodically by the City to assure that the sound level limits are technically feasible.

Construction activities that exceed the maximum permissible sound levels in Exhibit 11, when measured from the interior of buildings within a commercial district, are prohibited between 8:00 a.m. and 5:00 p.m. For the purposes of this limitation for commercial receiving property, interior sound levels will be measured only after every reasonable effort, including but not limited to closing windows and doors, is taken to reduce the effect of exterior construction noise.

Medina Municipal Code

The City of Medina has adopted the noise control provisions of the King County Code (KCC Chapters 12.86 through 12.100) governing excessive noise and noise control. In addition, the City of Medina Municipal Code Chapter 8.06.030, Limitation on Construction and Development Activity, provides specific regulations relating to construction. KCC Chapter 12.88.040 contains specific regulations for construction and equipment operation. At the time this report was written, the KCC construction regulations were the same as those provided under the Seattle Municipal Code (see Exhibits 11 through 14). For this reason, the KCC is not reprinted here.

The portion of the Medina Municipal Code that relates to construction activity states that:

- It is a violation of this chapter to engage in any commercial construction and development activity or to operate any heavy equipment before 7:00 a.m. and after 7:00 p.m. Monday through Friday and before 8:00 a.m. and after 5:00 p.m. on Saturday. No construction and development



activity or use of heavy equipment may occur on Sundays or holidays that are holidays observed by the city.

- The city manager or designee may grant written permission to engage in a construction and development activity or to operate heavy equipment after the hours of 7:00 p.m. and before 7:00 a.m. on Monday through Friday and after the hours of 5:00 p.m. and before 8:00 a.m. on Saturday, on Sundays, or on holidays that are observed by the city, if this will not unreasonably interfere with any residential use.

Haul Truck Criteria

The KCC (and the Medina Code by reference to the KCC) establishes maximum permissible sound levels for haul trucks that could be used for the project. Haul trucks are limited to 86 dBA for speeds of 35 mph or less and 90 dBA for speeds over 35 mph when measured at 50 feet.

Alarm Criteria

The WAC exempts sounds created by warning devices not operating continuously for more than 5 minutes. This exemption does not apply during nighttime hours (10:00 p.m. to 7:00 a.m.) for residential receiving property.

The City of Seattle now requires the use of broadband alarm systems or both backup spotters and broadband alarms on nighttime construction sites.

The KCC (and the Medina Code by reference to the KCC) exempts sounds at all times created by warning devices not operated continuously for more than 30 minutes per incident.

Construction Vibration Prediction Methods and Effect Guidelines

There are no specific regulations or criteria applicable to vibration related to construction activities. However, State Environmental Policy Act and National Environmental Policy Act guidelines allow federal, state, and local agencies the authority to determine acceptable levels of construction vibration using guidelines, research, and professional standards. King County, the City of Seattle, and the City of Medina have not adopted vibration guidelines that would apply to this project. For this project, WSDOT would rely on the USDOT guidelines for acceptable vibration levels from construction activities. The guidelines, based on information given in Exhibit 15, recommend that the maximum peak-particle-velocity levels remain below 1.27 inches per second at structures nearest the construction site. Vibration levels above 1.27 inches per second have the potential to cause architectural damage to normal dwelling houses with plastered ceilings and walls. USDOT also states that vibration levels above 0.64 inch per second can be annoying to people and disrupt normal working or living environments (USDOT 1980).

Peak particle velocity is the maximum vibration velocity of an object during a specific period of measurement.

Based on the information presented in Exhibit 15, the noise discipline analysts recommend that vibration monitoring be considered as a possible course of action during construction activities that might produce vibration levels near the USDOT maximum recommended vibration level of



1.27 inches per second. This would include pile-driving, vibratory sheet installation, soil compacting, and other construction activities that have the potential to cause high levels of vibration when the activity is within 50 to 75 feet of a property.

Exhibit 15. Peak Particle Velocity Guidelines

Vibration Velocity (in/sec)	Effects on Humans	Effects on Buildings
0 to 0.001	Imperceptible to people—no intrusion	Vibrations unlikely to cause damage of any type
0.04 to 0.08	Threshold of perception—possibility of intrusion	Vibrations unlikely to cause damage of any type
0.15	Vibrations perceptible	Recommended upper level of the vibration to which ruins and ancient monuments should be subjected
0.64	Level at which continuous vibrations begin to annoy people	Virtually no risk of “architectural” damage to normal buildings
1.27	Vibrations annoying to people in buildings (this agrees with the levels established for people standing on bridges and subjected to relatively short periods of vibrations)	Threshold at which there is a risk of “architectural” damage to normal dwelling houses with plastered ceilings and walls
2.54 to 3.81	Vibrations considered unpleasant by people subjected to continuous vibrations and unacceptable to some people walking on bridges	Vibrations at a greater level than normally expected from traffic, but would cause “architectural” damage and possible minor structural damage

in/sec = inches per second.

Source: USDOT 1980.

Noise Levels that could be Expected during Construction

The analysts considered temporary noise effects that construction could cause in the study area—effects that would end when project construction was completed. The highest construction noise levels within 50 feet of the SR 520 project area could reach 94 dBA- L_{max} or 88 dBA- L_{eq} .

Current SR 520 traffic noise levels nearest SR 520 range from a high of approximately 74 dBA- L_{eq} during peak volume periods to a low of approximately 54 dBA- L_{eq} during late night hours. Based on this general data, the residences nearest the project construction areas could be expected to have noise levels substantially louder than the current traffic noise levels from SR 520 during worst-case construction noise activities.

Typical construction equipment used for many roadway and structural activities would be required to complete the SR 520, I-5 to Medina project. Exhibit 16 lists equipment typically used for constructing this type of project, the activities for which the equipment would be used, and the corresponding maximum noise levels under normal use measured at 50 feet.



Exhibit 16. Construction Equipment List, Use, and Reference Maximum Noise Levels

Equipment	Typical Expected Project Use	L _{max} ^a (dBA)	Source ^b
Air Compressor	Used for pneumatic tools and general maintenance—all phases	70–76	1, 2, 3
Backhoe	General construction and yard work	78–82	2, 3
Concrete Pump	Pumping concrete	78–82	2, 3
Concrete Saw	Concrete removal, utilities access	75–80	2, 3
Crane	Materials handling, removal, and replacement	78–84	2, 3
Excavator	General construction and materials handling	82–88	2, 3
Forklift	Staging area work and hauling materials	72	1, 2, 3
Haul Truck	Materials handling, general hauling	86	2, 3
Jackhammer	Pavement removal	74–82	2, 3
Loader	General construction and materials handling	86	2, 3
Paver	Roadway paving	88	2
Pile Driver	To supply support for structure and hillside	99–105	2, 3
Power Plant	General construction use, nighttime work	72	2, 3
Pump	General construction use, water removal	62	2, 3
Pneumatic Tools	Miscellaneous construction work	78–86	3
Service Truck	Repair and maintenance of equipment	72	2, 3
Tractor Trailer	Material removal and delivery	86	3
Utility Truck	General project work	72	2
Vibratory Equipment	To shore up a hillside to prevent slides and soil compacting	82–88	2, 3
Welder	General project work	76	2, 3

^a Maximum noise level measured at a distance of 50 feet under normal operation.

^b Sources of noise levels presented:

1 Portland, Oregon light rail, I-5 preservation, and Hawthorne Bridge construction projects.

2 Measured data from other projects in the Portland, Oregon area.

3 USDOT or other construction noise source.

Project Construction Phases and Noise Levels

Four general construction phases would be required to complete the SR 520, I-5 to Medina project. Typical construction phases for the project would include the following:

- Preparing for construction of new structures
- Constructing new structures and paving roadways
- Conducting miscellaneous activities, including striping, lighting, and providing signs
- Demolishing existing structures



To provide the public with a general understanding of how loud construction might be, the analysts performed a study that assumed worst-case noise levels based on the four expected construction phases plus construction pile-driving activities. The noise levels presented in this report are for periods of maximum construction activity. The actual noise levels experienced during construction would generally be lower than those described in this report.

The noise discipline team predicted construction noise levels using the methods described in the *FHWA Highway Construction Noise, Measurement, Prediction and Mitigation* (USDOT 1997) and the *FHWA Roadway Construction Noise Model*, version 1.1 (USDOT 2008). In addition to the methods provided by the FHWA, experience on major construction projects assist in providing the most accurate information available. The information provided includes descriptions of the types of construction activities required for this type of project, noise levels associated with specific construction equipment, and overall construction-related noise and vibration projections. Using the reference noise levels provided in Exhibit 16, the analysts projected typical construction noise levels for several distances from the SR 520, I-5 to Medina project work area. Exhibit 17 identifies the overall noise levels for each of the four typical construction phases as measured at 50 feet from the construction activity.

Exhibit 17. Noise Levels for Typical Construction Phases at 50 Feet from Work Site

Scenario ^a	Equipment ^b	L _{max} ^c (dBA)	L _{eq} ^d (dBA)
Preparing for construction of new structures	Air compressor, backhoe, concrete pump, crane, excavator, forklift, haul truck, loader, water pump, power plant, service truck, tractor trailer, utility truck, and vibratory equipment	94	87
Constructing new structures and paving roadways	Air compressor, backhoe, cement mixer, concrete pump, crane, forklift, haul truck, loader, paver, pump, power plant, service truck, tractor trailer, utility truck, vibratory equipment, and welder	94	88
Conducting miscellaneous activities, including striping, lighting, and providing signs	Air compressor, backhoe, crane, forklift, haul truck, loader, pump, service truck, tractor trailer, utility truck, and welder	91	83
Demolishing existing structures	Air compressor, backhoe, concrete saw, crane, excavator, forklift, haul truck, jackhammer, loader, power plant, pneumatic tools, water pump, service truck, and utility truck	93	88

^a Operational conditions under which the noise levels are projected.

^b Normal equipment in operation under the given scenario.

^c L_{max} (dBA) is an average maximum noise emission for the construction equipment under the given scenario.

^d L_{eq} (dBA) is an energy average noise emission level for construction equipment operating under the given scenario. For this type of equipment, the L_{eq} is approximately equal to the L₅₀ (that is, noise levels that are exceeded 50 percent of the time).

Note: Combined worst-case noise levels for all equipment at a distance of 50 feet from work site, as calculated using the *FHWA Roadway Construction Noise Model* (USDOT 2008).



Each of the four defined construction phases is discussed below, including the assumptions about the equipment that would be used in each of the phases. Pile-driving and construction vibration effects are discussed separately.

Preparing for Construction of New Structures

Major noise-producing equipment used during the preparation stage could include concrete pumps, cranes, excavators, haul trucks, loaders, and tractor trailers. Maximum noise levels could reach 94 dBA L_{max} or 87 dBA L_{eq} at the nearest residences (50 feet) during heavy construction activities during this phase. Other less noticeable noise-producing equipment expected during the preparation phase includes backhoes, air compressors, forklifts, water pumps, power plants, service trucks, and utility trucks.

Constructing New Structures and Paving Roadways

The loudest noise sources during new bridge construction would include cement mixers, concrete pumps, pavers, haul trucks, and tractor trailers. The cement mixers and concrete pumps would be required to construct the superstructure and substructure. The pavers and haul trucks would be used to provide the final surface on the roadway and to construct the transitions from the at-grade roadway to the new structures. Maximum noise levels could reach 94 dBA L_{max} or 87 dBA L_{eq} at the closest receiver locations during heavy periods of construction.

Conducting Miscellaneous Activities

Following heavy construction, general construction activities such as installing bridge railings, providing signage, striping roadways, and conducting other general activities would occur. These less-intensive activities would not be expected to produce noise levels above 91 dBA L_{max} or 83 dBA L_{eq} at 50 feet except during rare occasions, and then only for short periods. In general, the miscellaneous activities are expected to produce noise levels that would be less than the short-term noise-exceedance limits set forth in the WAC, the Seattle Municipal Code, and the Medina Municipal Code.

Demolishing Existing Structures

Demolition of the existing structures would require heavy equipment such as concrete saws, cranes, excavators, backhoes, haul trucks, jackhammers, loaders, and tractor trailers. Maximum noise levels could reach 93 dBA L_{max} or 88 dBA L_{eq} at the nearest residences.

The construction noise analysis assumed that there would be construction staging areas along the proposed bridges during demolition and construction activities. The typical maximum noise levels listed in Exhibit 17 would occur only periodically during the heaviest periods of construction. Actual hourly noise levels could be substantially lower than those stated, depending on the level of activity at that time.

Exhibit 18 translates the noise levels in Exhibit 15 into a graph showing estimated maximum noise levels for each construction phase at various distances from the construction site. This graph can be used to approximate construction noise levels at noise-sensitive properties at various distances from



construction activity. For reference, the graph also includes measured typical daytime and nighttime noise levels at select locations near the project corridor.

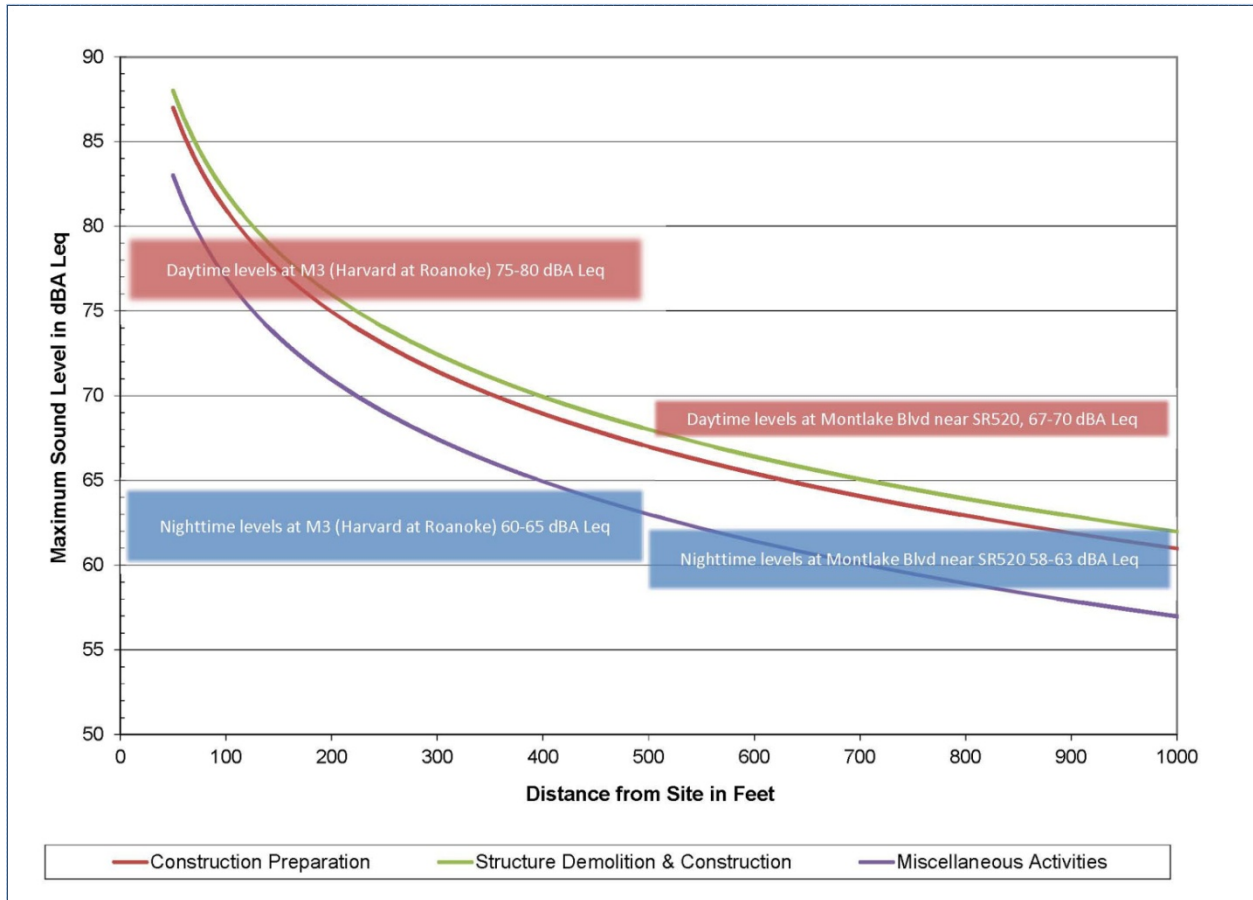

Exhibit 18. Estimated Hourly Maximum Construction Noise for Different Distances from Construction Site

Pile-Driving

Vibratory and impact equipment (such as pile-driving and vibratory sheet installations) is another major noise source that might be required during construction preparation. These activities may be necessary to provide support for temporary bridges as well as for the new structure. Vibratory and impact equipment may be used to shore up loose soils prior to the installation of retaining walls.

Pile-driving can produce maximum short-term noise levels of 99 to 105 dBA L_{max} at 50 feet. Actual levels can vary, depending on the distance and topographical conditions between the pile-driving location and the receiver location. The noise-level limits for pile-driving (see Exhibit 14) can vary depending on the frequency of pile-driving and the number of pile drivers operating at one time in any one area. Exhibit 19 provides a graph of a maximum pile-driving noise level based on 105 dBA at 50 feet for distances up to 1,000 feet. In the event that pile-driving exceeds the maximum noise levels set forth in Exhibit 14, a noise variance would be requested from the local jurisdiction.



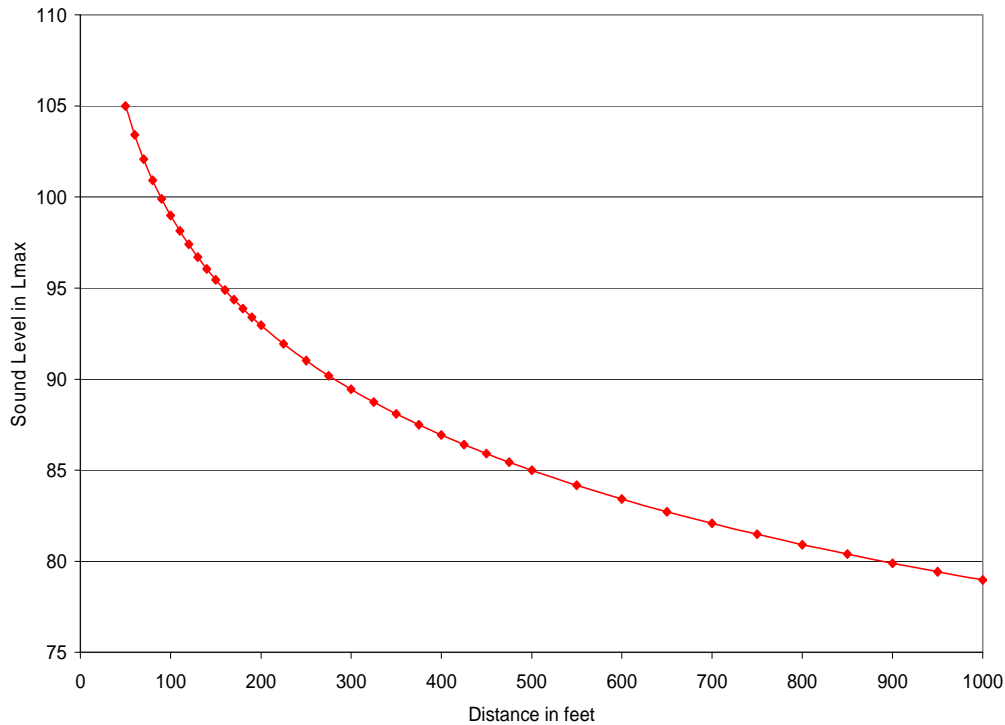

Exhibit 19. Estimated Typical Maximum Pile-Driving Noise Levels, Assuming 105 dBA at 50 Feet

Construction Vibration Effects

Vibration associated with general construction can affect surrounding receivers. Major vibration-producing activities would occur primarily during demolition and preparation for the new bridges. Activities that have the potential to produce a high level of vibration include pile-driving, vibratory shoring, soil compacting, and some hauling and demolition. Vibration effects from pile-driving or vibratory sheet installations could occur within 50 to 100 feet of sensitive receivers. It is unlikely that vibration levels would exceed 0.5 inch per second at distances greater than 100 feet from the construction sites (see Exhibit 15 for peak particle velocity guidelines). Exhibit 20 shows estimated contoured views of the potential pile-driving noise that could occur with each of the design options. The noise-level contours are based on a maximum of 105 dBA at 50 feet, assuming a drop-off rate of 6 dBA per doubling of distance out to 1,000 feet.

The contours shown in Exhibit 20 should serve as conservative estimates because they ignore excess attenuation resulting from ground and atmospheric absorption.



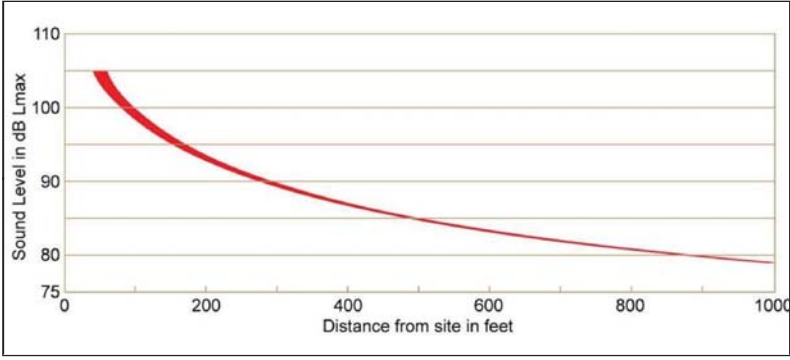
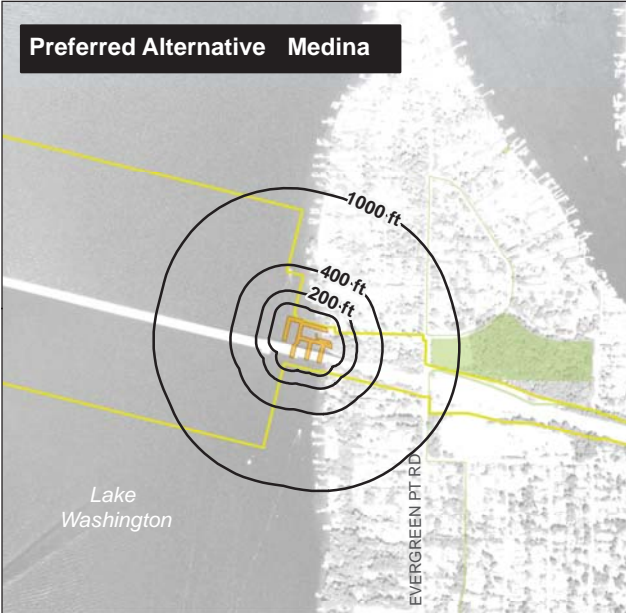
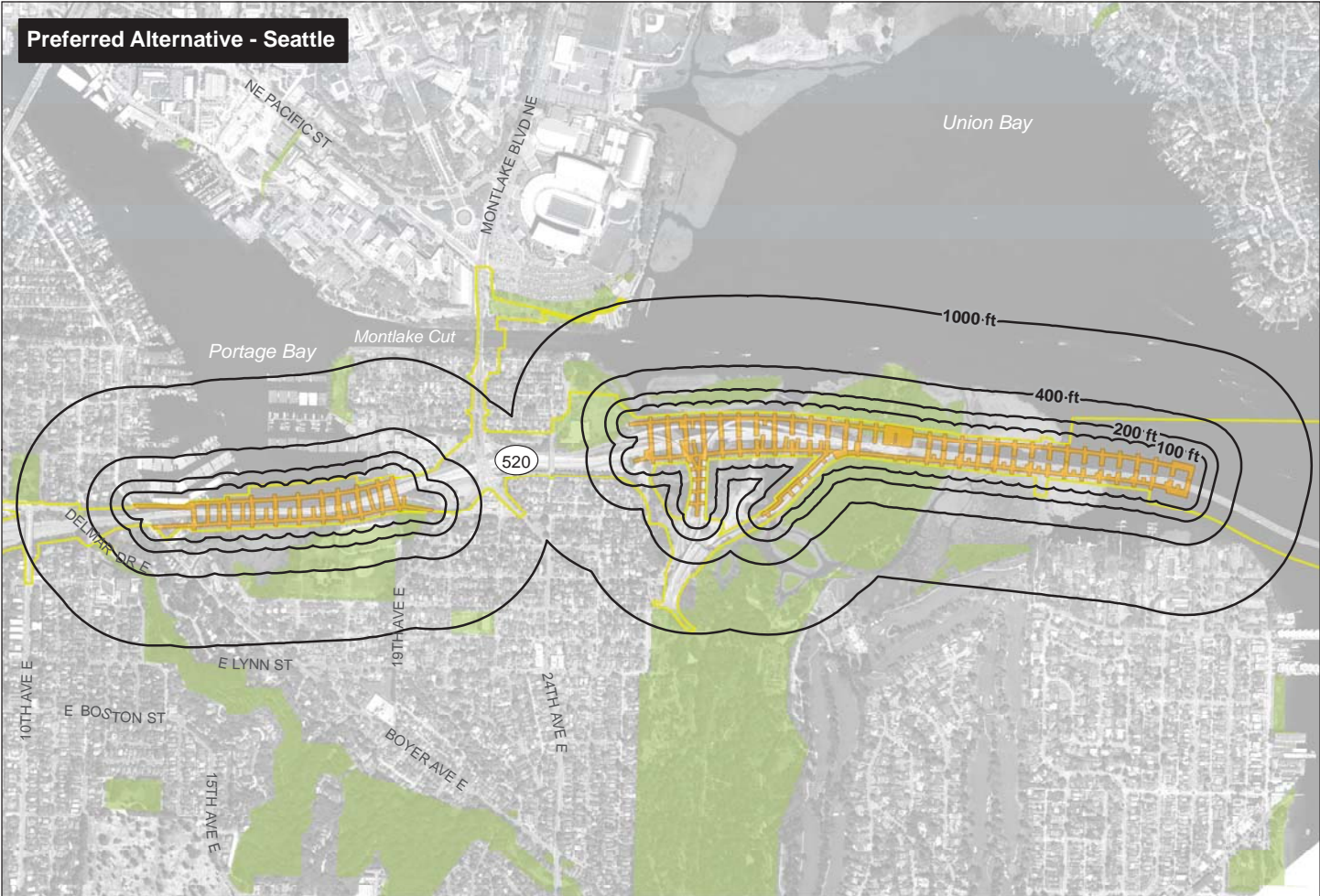

Note: Pile driving activities and locations would be similar for the Preferred Alternative and Options A, K, and L. Predicted Pile Driving Noise Levels versus Distance (worst case noise levels based on 105 dB Lmax at 50 feet with no additional shielding attenuation) Pile driving noise would occur only for limited durations during the construction period, and would be required to meet the noise control ordinance or have a variance.

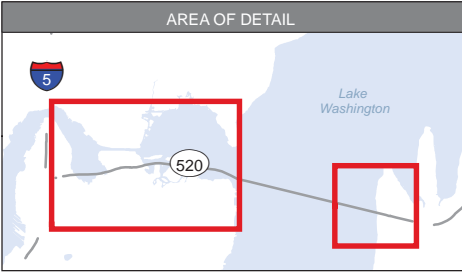

- Distance Contour from Pile Driving Activities
 - Limits of Construction
 - Construction Work Bridge
 - Park
- 0 375 750 1,500 Feet

Source: King County (2006) Aerial Photo, CH2M HILL (2008) GIS Data (Park), Horizontal datum for all layers is NAD83(91); vertical datum for layers is NAVD88.

Exhibit 20. Maximum Pile Driving Noise in the Study Area
I-5 to Medina: Bridge Replacement and HOV Project

Noise and associated construction activity can disturb wildlife by causing stress and altering behavior patterns and, therefore, interfering with activities such as reproduction and feeding. The degree of disturbance would depend on the noise level, timing, and duration of construction activities, as well as the sensitivity of the individual animals. In general, most wildlife species found in areas adjacent to the SR 520, I-5 to Medina project site are adapted to urban conditions and highway noise. However, loud construction activities could displace some animals or discourage them from using adjacent habitats. In extreme cases, birds could abandon their nests in response to noise disturbance. See the Ecosystems Discipline Report (WSDOT 2009c) for more details on the potential effects of construction noise on wildlife and habitat, including fish and aquatic habitat.

How would operation of the project affect noise levels?

Operation Effects on Noise Levels Compared to the SDEIS Options

In order to compare the SDEIS noise effects to the noise effects of the Preferred Alternative, the analysts first modeled the Preferred Alternative design without noise mitigation, and without the 4-foot tall concrete traffic barrier. This allows for a fair comparison between the options, before any noise reduction or mitigation. The analysts then assessed the noise-reducing effect of the 4-foot traffic barrier included as part of the Preferred Alternative before determining what noise abatement to recommend. Compared to the SDEIS options, the Preferred Alternative with the project's noise reducing design elements and recommended noise abatement has a slightly higher overall number of residual noise effects in the project alignment area. Overall, with the Preferred Alternative, 207 residences or residential equivalents would have noise levels that meet or exceed the WSDOT NAC (see Exhibit 1) before accounting for the noise reducing design elements or noise abatement measures. With the project's noise reducing design elements and the proposed noise abatement measures under the Preferred Alternative, the number of residences or residential equivalents meeting or exceeding the WSDOT NAC is reduced to 143. With the SDEIS options, the residual noise effects with noise abatement measures totaled 94, 123, and 119 residences, respectively. With the No Build Alternative, there would be 287 traffic noise effects within the project area. Currently, 270 residences have noise levels approaching or exceeding the NAC. Attachment 3 provides the calculations used to determine the residential equivalent calculations for relevant areas within the project study area.

On a neighborhood-by-neighborhood basis, with the recommended noise abatement measures and noise reducing design elements, there would be no difference between the Preferred Alternative and the SDEIS options in Laurelhurst, Madison Park, or Medina. After the abatement measures are applied, there are no noise level effects identified in these neighborhoods with any of the SDEIS options or the Preferred Alternative.

Compared to the SDEIS options, there would be a higher number of affected residences with the Preferred Alternative within the Portage Bay/Roanoke neighborhood, the Montlake neighborhoods north and south of SR 520, and within the University of Washington.



Within the Portage Bay/Roanoke neighborhood, there would be 22 affected residences with the Preferred Alternative, which is higher than with each of the SDEIS options (13 residences with Option A and 16 residences each with Options K and L). Within the North Capitol Hill neighborhood, 53 residences would have noise levels approaching or exceeding the NAC with the Preferred Alternative, which is reduced to 44 residences when accounting for the 4-foot traffic barrier, compared to 35 affected residences with each of the SDEIS options.

Within Montlake north of SR 520, there would be 34 affected residences and residential equivalents with the Preferred Alternative before accounting for the 4-foot traffic barrier. With the 4-foot traffic barrier, the number of affected residences is reduced from 34 to 28, compared to 0, 19, and 18 with SDEIS Options A, K, and L, respectively. Within Montlake south of SR 520, there would be 48 affected residences and residential equivalents with the Preferred Alternative without the 4-foot traffic barrier. With the traffic barrier, the number of affected residences is reduced to 39, compared to 28, 24, and 24 with Options A, K, and L, respectively.

Within the University of Washington, there would be seven affected residential equivalents with the Preferred Alternative, which is reduced to four with the 4-foot traffic barrier, compared to two, two, and four with SDEIS Options A, K, and L, respectively. Because there are no project-related improvements north of the Pacific Street intersection near the University of Washington, no noise abatement was considered for any identified traffic noise effects in this area. Nonetheless, noise-related information is provided for purposes of continuity with the prior analysis.

Within the Arboretum, the number of residential equivalents that would have noise levels approaching or exceeding the NAC is predicted at 27, which is reduced to 5 with the 4-foot traffic barrier. This number (5), is significantly less when comparison to 16, 27, and 22 residential equivalents with SDEIS Options A, K, and L, respectively.

In general, in those areas where the number of affected residences would be lower with the Preferred Alternative compared to the SDEIS options (for example, in the Arboretum), it is due to noise reducing project design elements. Design elements of the Preferred Alternative include elevated roadways, elimination of existing roadways, reduced speed between I-5, across the Portage Bay Bridge to the new Montlake lid, and the inclusion of the 4-foot tall concrete traffic barriers with noise-absorptive materials along elevated and at-grade segments of the corridor. WSDOT is also considering using quieter concrete pavement that may also provide some level of noise reduction.

The traffic noise model does not provide for modeling acoustically absorptive barriers or different pavement types. The results in this report present the results of modeling standard concrete-type barriers and typical roadway surfaces. In a report prepared by WSDOT titled *Special Noise Barrier Applications Phase II*, it was concluded that single wall absorptive barriers could provide an additional noise reduction of up to 2 dBA when compared to a standard reflective barrier (see full WSDOT report in Attachment 4). The report further advises that the additional noise reduction would be achieved if and only if the line-of-sight between the traffic and the receiver is broken by at least 2 feet. Depending on the local topography, the 4-foot noise absorptive traffic barrier may



achieve this level of line-of-sight break for some locations. Overall, the conservative noise levels stated in this report that are based on the use of standard concrete-type barriers may be further reduced by up to 2 dBA at some locations. Where the 4-foot barriers do not break the line-of-sight by 2 feet or more, the additional reduction due to installing acoustically absorptive barriers is expected to be minimal (less than 1 dBA).

Noise reduction from pavements are still uncertain and therefore, no additional noise reduction was included as part of this analysis. More information on the noise reducing potential of pavements is provided later in this addendum in the section “Alternative Noise-Reducing Design Elements” under “What has been done to avoid or minimize negative effects from noise?”

In areas where the number of affected residences is higher with the Preferred Alternative compared to the SDEIS options, the difference is due primarily to the fact that no noise walls are recommended under the Preferred Alternative, whereas noise walls were recommended with one or more of the SDEIS options.

Operation Effects on Noise Levels Compared to the No Build Alternative

This section discusses the overall effects of the No Build Alternative and operation of the Preferred Alternative in the study area, including discussions of the effects on individual communities and neighborhoods.

Preferred Alternative

With the Preferred Alternative, the number of residences approaching or exceeding the NAC would decrease to 150 compared to 287

under the No Build Alternative. The modifications in the horizontal and vertical alignments of the project roadways, lower posted speeds of 45 mph across the Portage Bay structure (these lower speeds begin at I-5 and extend to the Montlake lid), construction of new retaining walls and 4-foot tall concrete traffic barriers with noise-absorptive materials, and the addition of lids at 10th Avenue East/Delmar Drive East (Delmar lid) and Montlake Boulevard (Montlake lid) would be the primary reasons for the reduction in noise levels.

Exhibits 21 through 26 show the receiver locations and modeled sound levels. For each receiver, the existing, 2030 No Build Alternative, and the 2030 Preferred Alternative peak-hour noise levels are shown. Complete tabulated data of the existing, 2030 No Build, and the 2030 Preferred Alternative peak hour noise levels are provided in Attachment 5. Exhibit 27 presents the results of the traffic noise analysis in terms of relative noise-level changes that could be expected for each neighborhood.

I-5 to Medina Project Corridor Summary (without Noise Mitigation)			
Number of Residences and Residential Equivalents Where Noise Levels Would Approach or Exceed NAC			
(% of residences where noise levels would approach or exceed NAC based on the total residences identified in the study area) ^a			
Current	No Build Alternative	Preferred Alternative	Preferred Alternative with Noise Reducing Design Elements
270 (32.3%)	287 (34.3%)	207 (24.7%)	150 (17.9%)

^a The percentages of residences are based on a total of 838 residences.



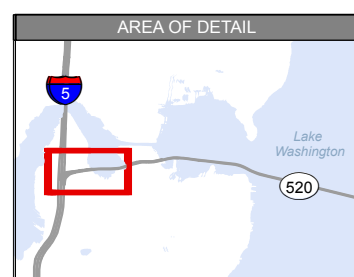
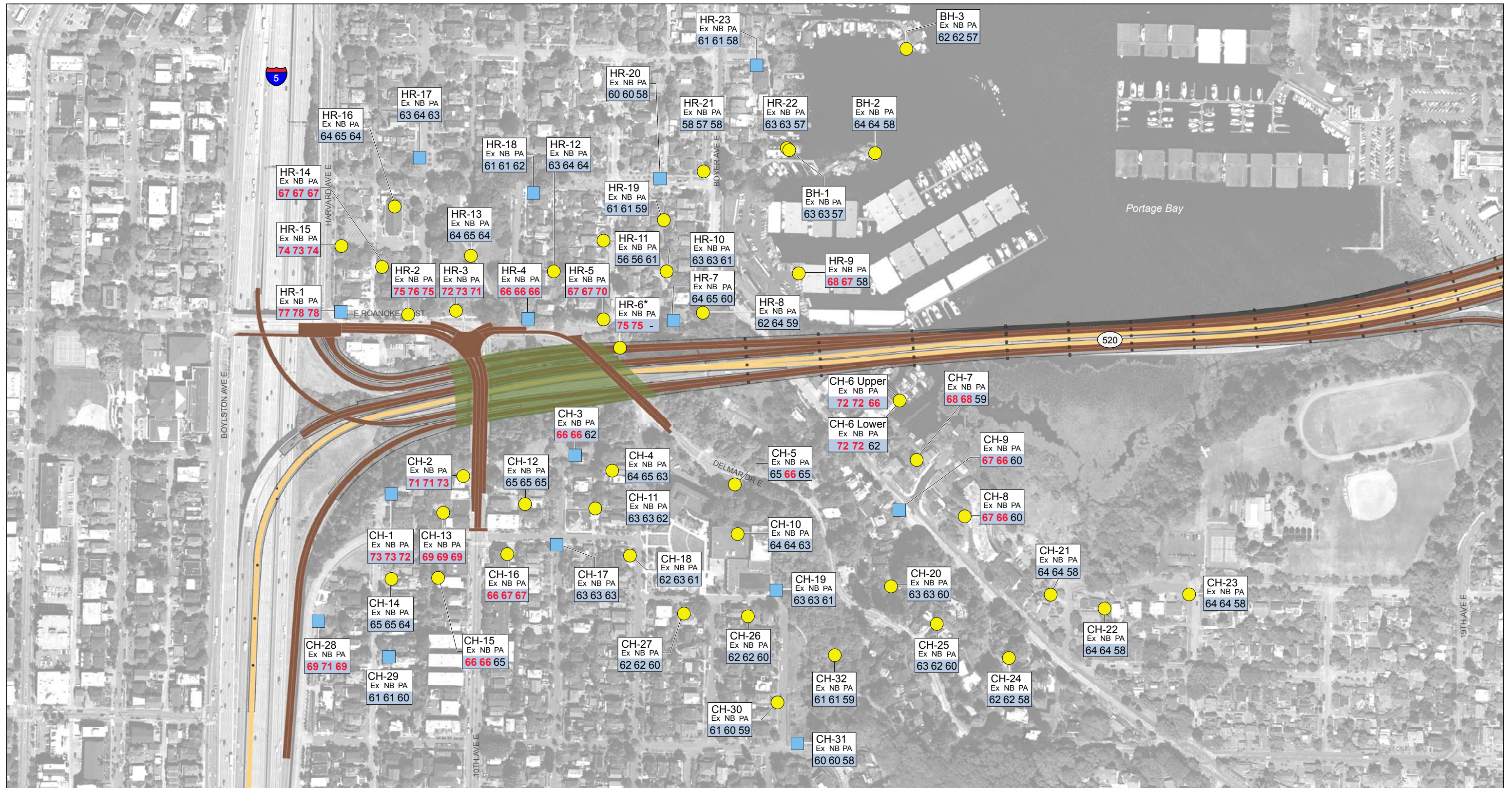

- Modeling Location
- Monitor and Modeling Location
- Column
- Lid
- General-purpose Lane
- HOV, Direct Access, and/or Transit-only Lanes
- Westbound Managed Shoulder

*Note: Receiver to be displaced by project footprint; modeling location no longer valid for the Preferred Alternative.

Modeling number
 Alternatives
 (Existing, 2030 No Build, 2030 Preferred Alternative)
 Equivalent sound level (L_{eq}) in A-weighted decibels (dBA)
 Noise levels indicated in red lettering exceed the NAC



Source: King County (2006) aerial photo. Horizontal datum for all layers is NAD83(91); vertical datum for layers is NAVD88.



Exhibit 21. Traffic Noise Modeling Locations and Levels in Portage Bay, Roanoke, and North Capitol Hill Neighborhoods
SR 520, I-5 to Medina: Bridge Replacement and HOV Project

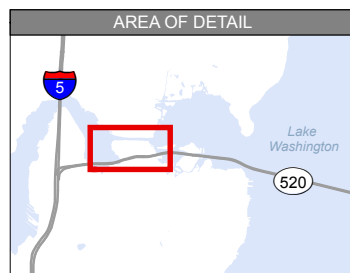
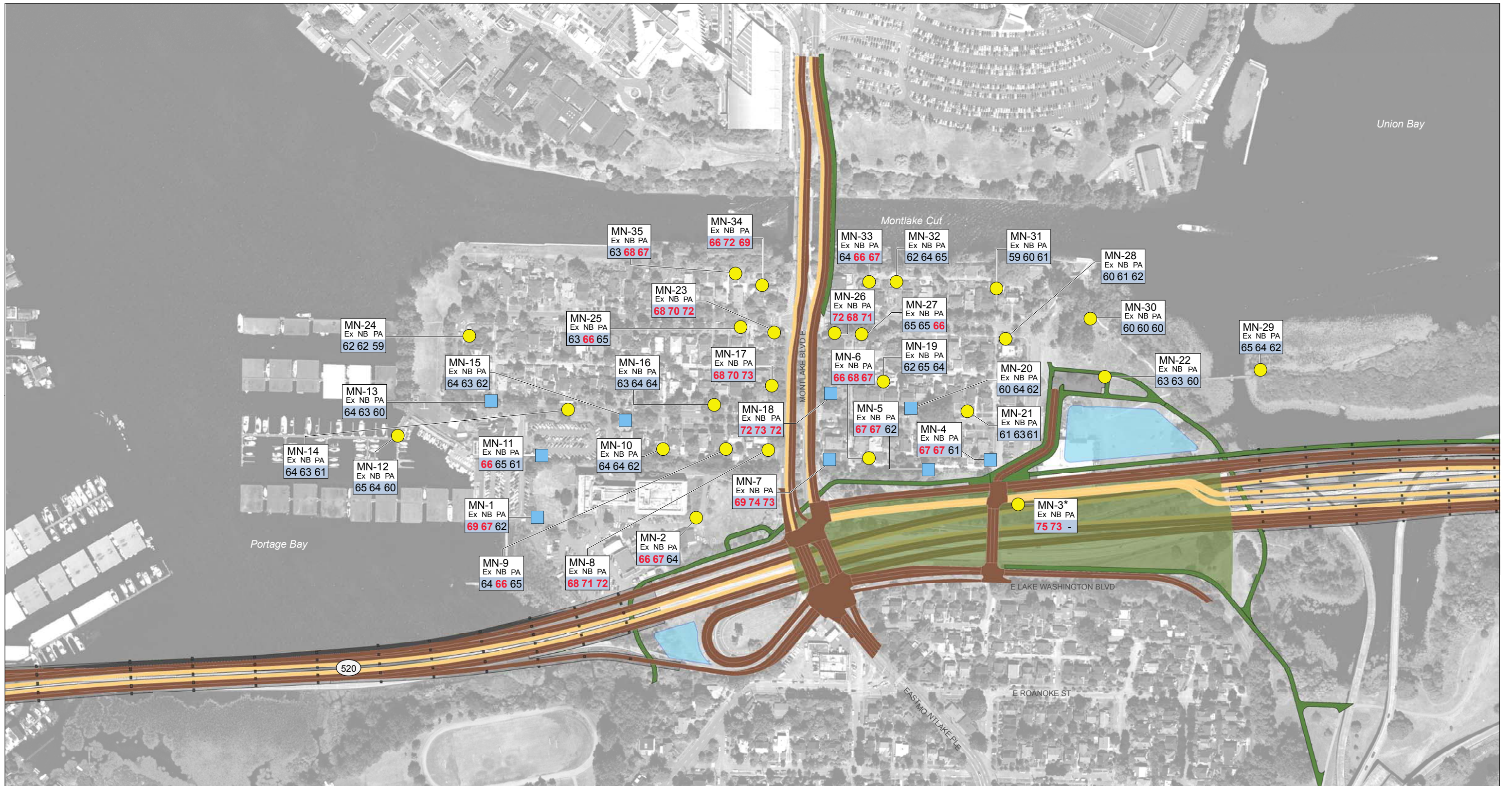

- Modeling Location
- Monitor and Modeling Location
- Column
- Lid
- Proposed Bicycle/Pedestrian Path
- General-purpose Lane
- HOV, Direct Access and/or Transit-only Lanes
- Westbound Managed Shoulder
- Stormwater Treatment Facility

MN-5
Ex NB PA
67 67 62 Modeling number
 Alternatives (Existing, 2030 No Build, 2030 Preferred Alternative)
 Equivalent sound level (L_{eq}) in A-weighted decibels (dBA)
 Noise levels indicated in red lettering exceed the NAC

*Note: Receiver to be displaced by project footprint; modeling location no longer valid for the Preferred Alternative.



Source: King County (2006) aerial photo. Horizontal datum for all layers is NAD83(91); vertical datum for layers is NAVD88.



Exhibit 22. Traffic Noise Modeling Locations and Levels in Montlake North
 SR 520, I-5 to Medina: Bridge Replacement and HOV Project

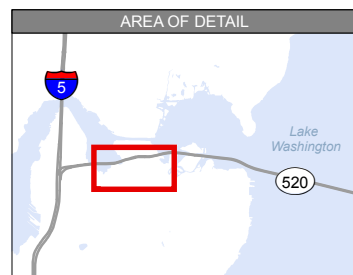

- Modeling Location
 - Monitor and Modeling Location
 - Column
 - Lid
 - Proposed Bicycle/Pedestrian Path
 - General-purpose Lane
 - HOV, Direct Access and/or Transit-only Lanes
 - Westbound Managed Shoulder
 - Stormwater Treatment Facility
- *Note: Receiver to be displaced by project footprint; modeling location no longer valid for the Preferred Alternative.
- MS-5
Ex NB PA
70 68 67

 - Modeling number
 - Alternatives (Existing, 2030 No Build, 2030 Preferred Alternative)
 - Equivalent sound level (L_{eq}) in A-weighted decibels (dBA)
 - Noise levels indicated in red lettering exceed the NAC



Source: King County (2006) aerial photo. Horizontal datum for all layers is NAD83(91); vertical datum for layers is NAVD88.



Exhibit 23. Traffic Noise Modeling Locations and Levels in Montlake South
SR 520, I-5 to Medina: Bridge Replacement and HOV Project

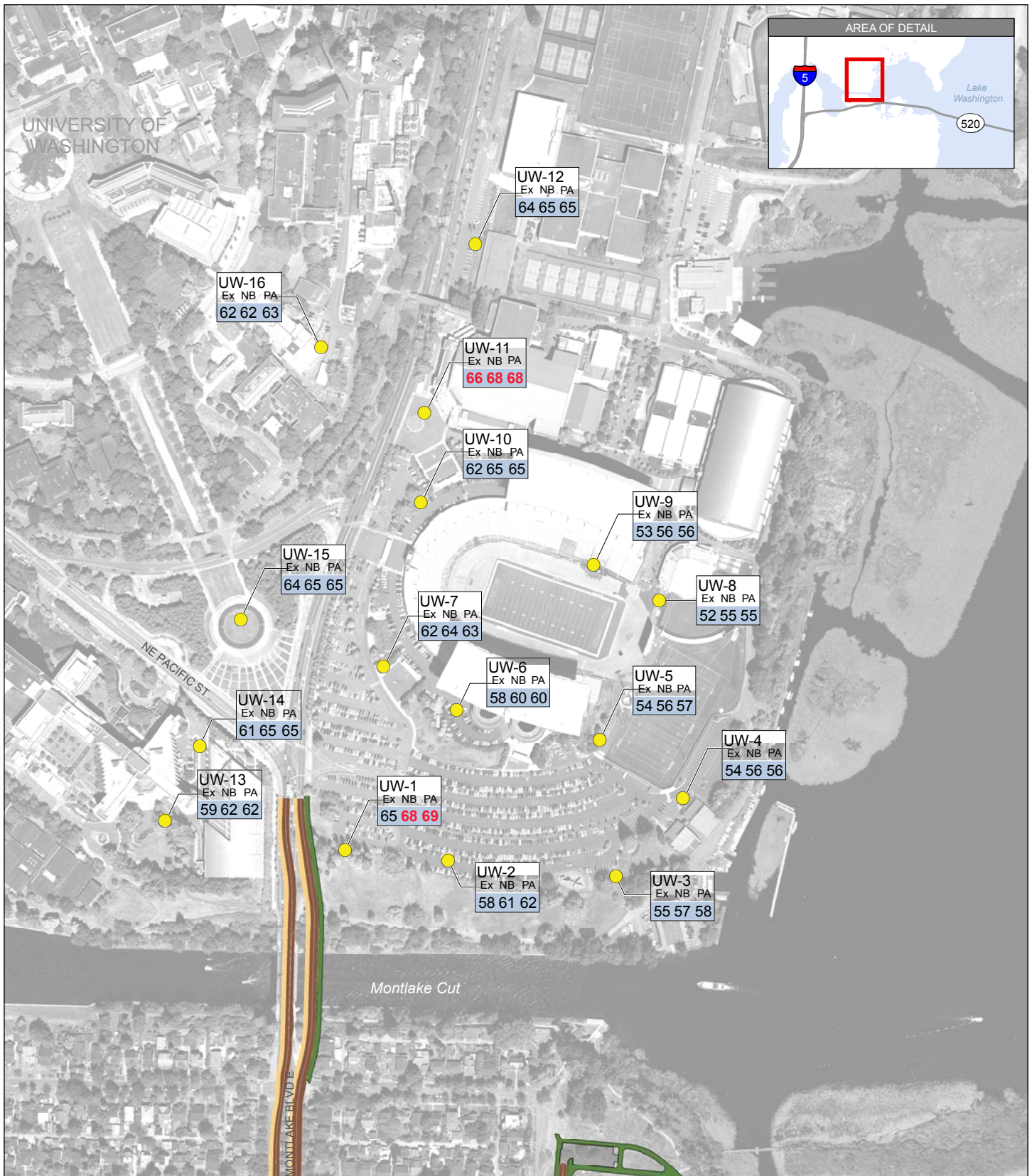

- Modeling Location
 - Column
 - Proposed Bicycle/ Pedestrian Path
 - General-purpose Lane
 - HOV, Direct Access, and/or Transit-only Lanes
 - Westbound Managed Shoulder
- Modeling number
- Alternatives
(Existing, 2030 No Build, 2030 Preferred Alternative)
- Equivalent sound level (L_{eq}) in A-weighted decibels (dBA)
- Noise levels indicated in red lettering exceed the NAC
- UW-1
Ex NB PA
65 68 69



Source: King County (2006) aerial photo. Horizontal datum for all layers is NAD83(91); vertical datum for layers is NAVD88.



Exhibit 24. Traffic Noise Modeling Locations and Levels in the University of Washington
SR 520, I-5 to Medina: Bridge Replacement and HOV Project

This page intentionally left blank.



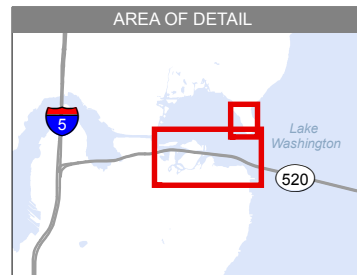
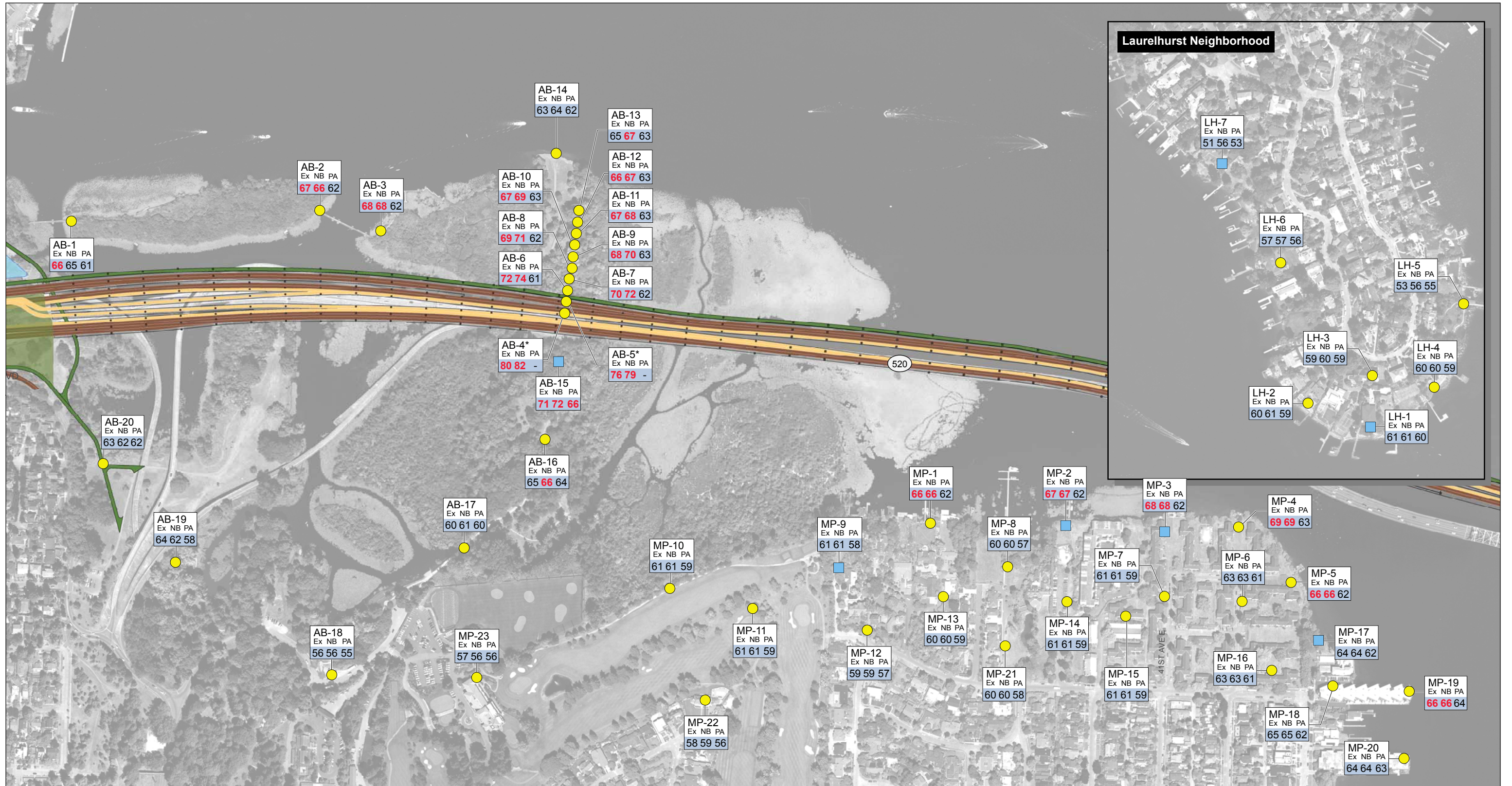

- Modeling Location
 - Monitor and Modeling Location
 - Column
 - Lid
 - Proposed Bicycle/Pedestrian Path
 - General-purpose Lane
 - HOV, Direct Access, and/or Transit-only Lanes
 - Westbound Managed Shoulder
 - Stormwater Treatment Facility
- *Note: Receiver to be displaced by project footprint; modeling location no longer valid for the Preferred Alternative.
- MP-5
Ex NB PA
66 66 62
- Modeling number
 - Alternatives (Existing, 2030 No Build, 2030 Preferred Alternative)
 - Equivalent sound level (L_{eq}) in A-weighted decibels (dBA)
 - Noise levels indicated in red lettering exceed the NAC

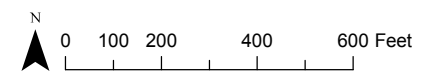

Source: King County (2006) aerial photo. Horizontal datum for all layers is NAD83(91); vertical datum for layers is NAVD88.

Exhibit 25. Traffic Noise Modeling Locations and Levels in the Washington Park Arboretum, Madison Park, and Laurelhurst Neighborhoods
SR 520, I-5 to Medina: Bridge Replacement and HOV Project

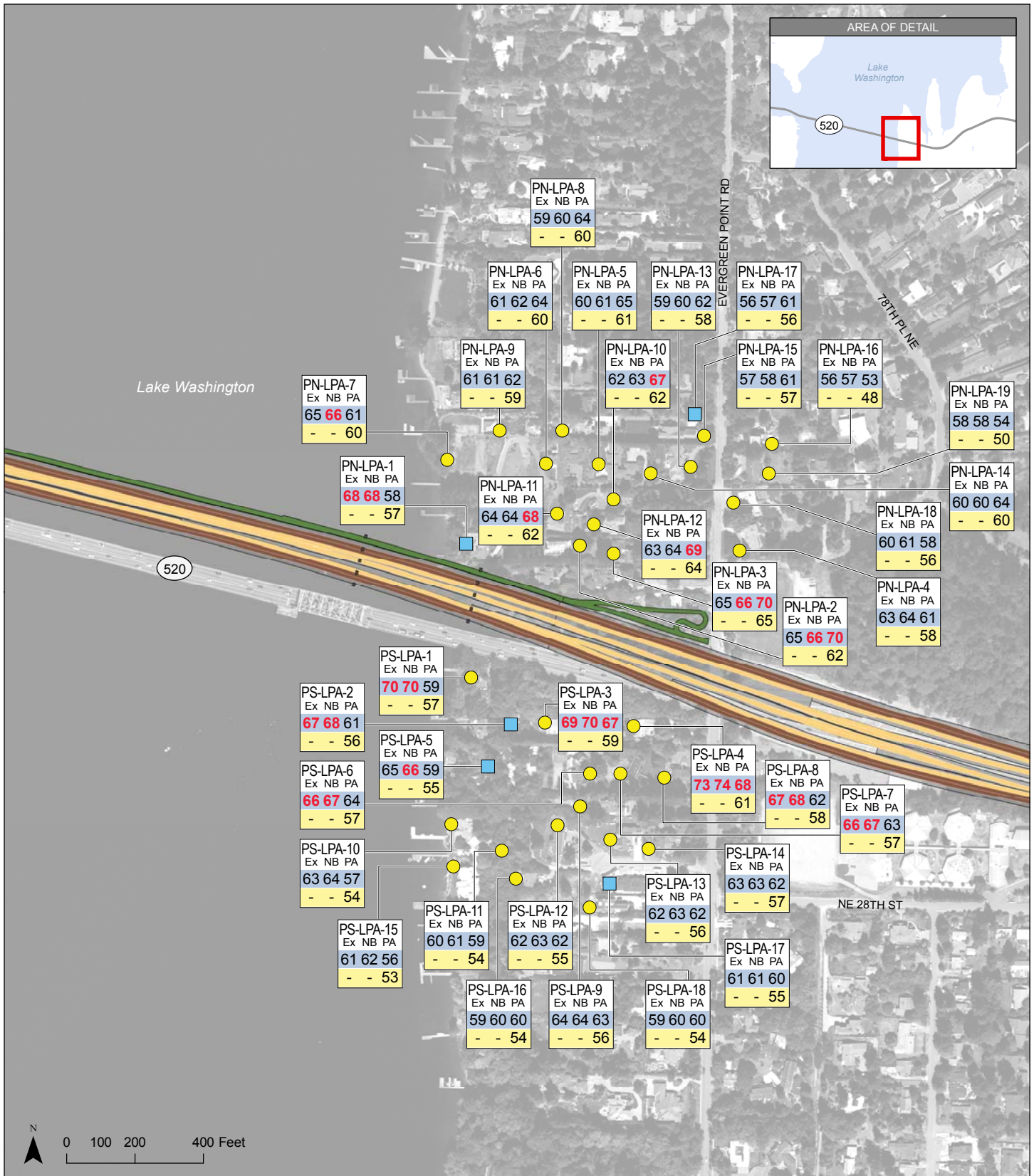

● Modeling Location
■ Monitor and Modeling Location
• Column
 Proposed Bicycle/ Pedestrian Path
 General-purpose Lane
 HOV, Direct Access, and/or Transit-only Lanes
 Westbound Managed Shoulder

PS-LPA-6	Ex	NB	PA
66	67	64	
-	57		

Modeling number
 Alternatives (Existing, 2030 No Build, 2030 Preferred Alternative)
 Equivalent sound level (L_{eq}) in A-weighted decibels (dBA)
 Equivalent sound level (L_{eq}) in A-weighted decibels (dBA) with recommended noise wall(s)
 Noise levels indicated in red lettering exceed the NAC

Source: King County (2006) aerial photo. Horizontal datum for all layers is NAD83(91); vertical datum for layers is NAVD88.

Exhibit 26. Traffic Noise Modeling Locations and Levels in the Medina North and South Neighborhoods
 SR 520, I-5 to Medina: Bridge Replacement and HOV Project

This page intentionally left blank.



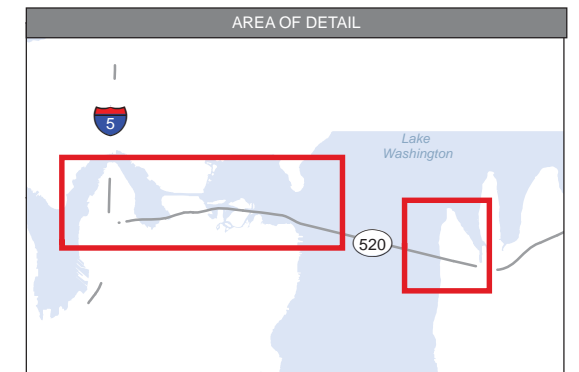
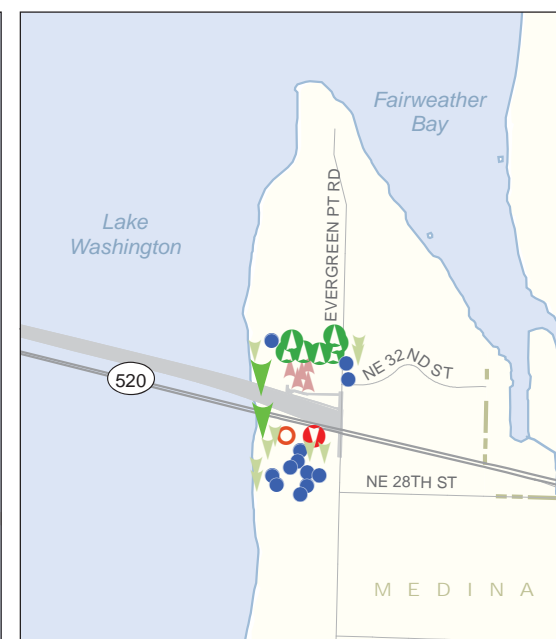
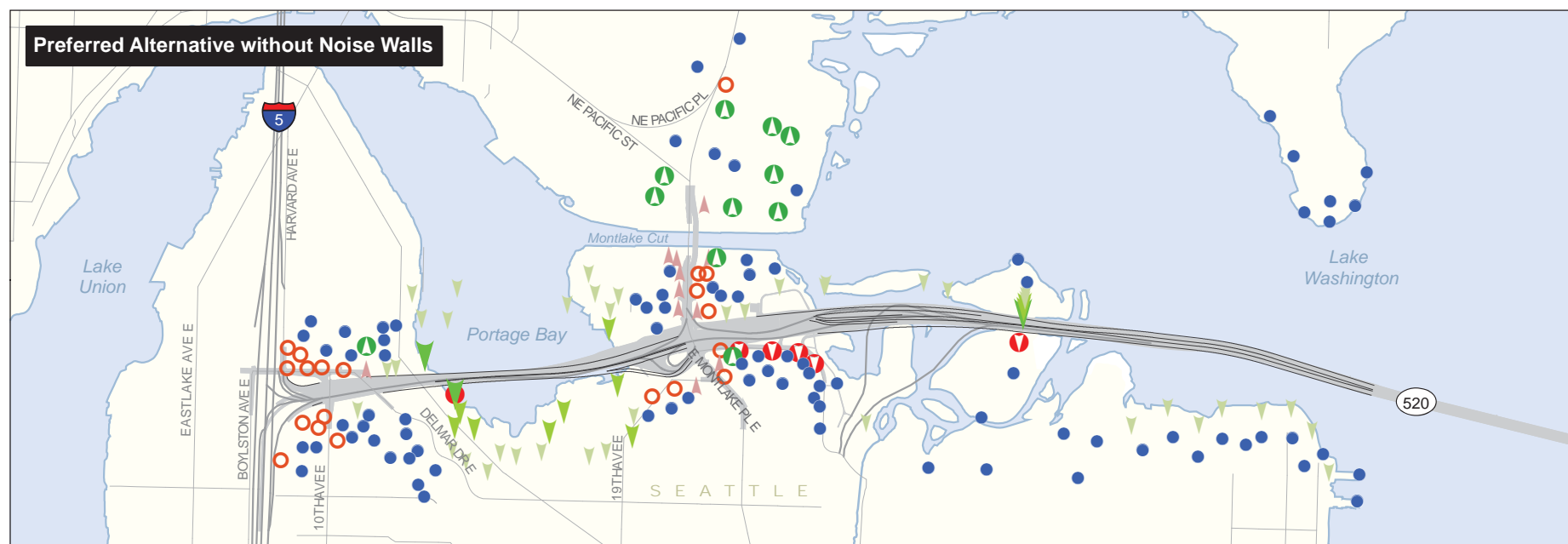
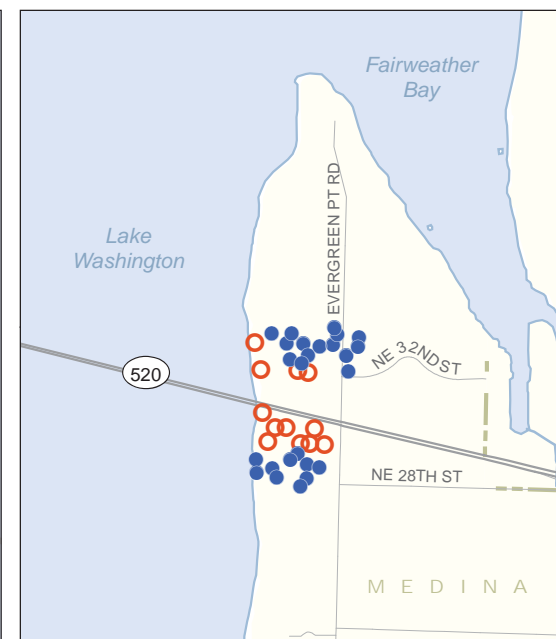
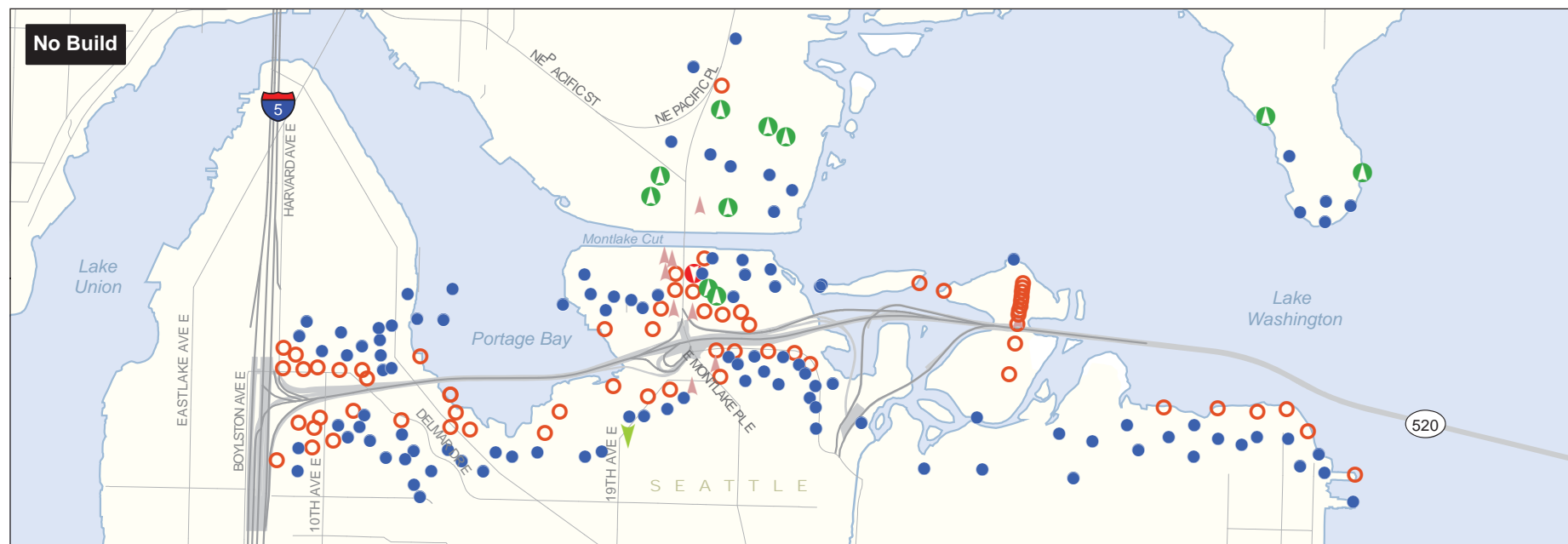
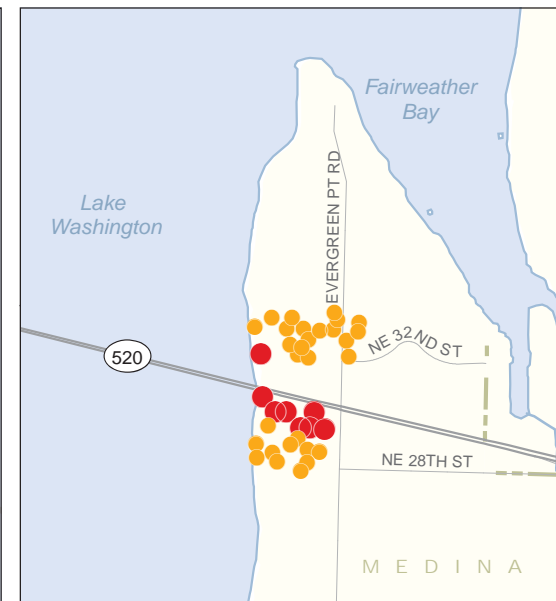
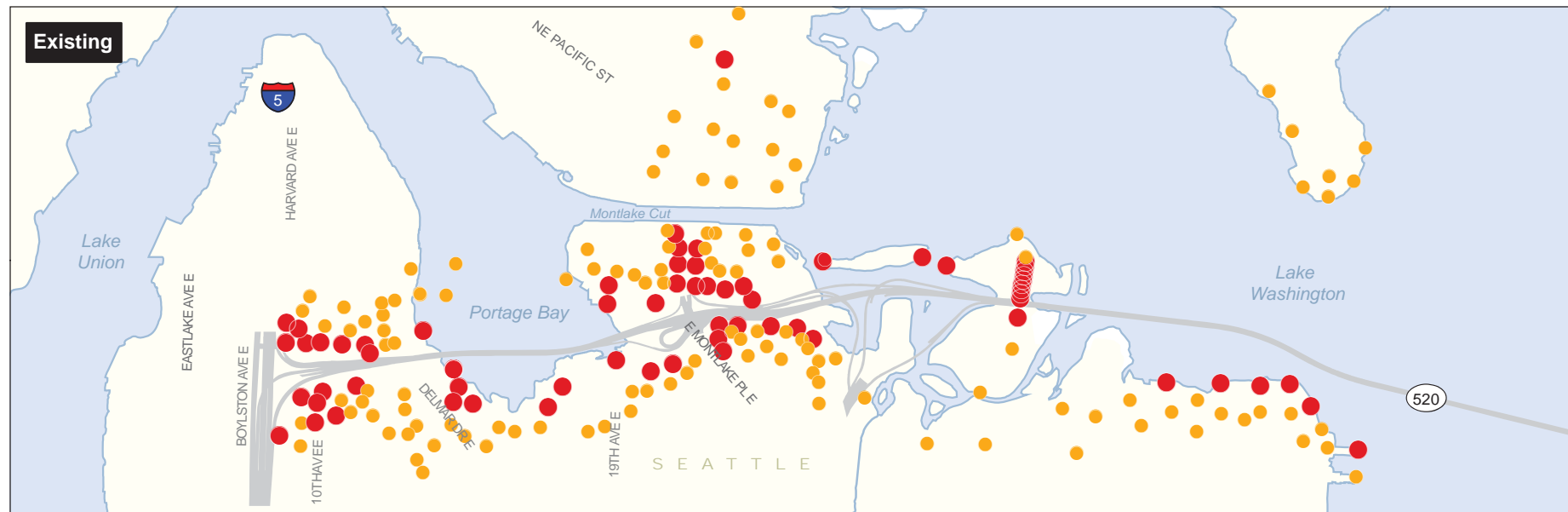

- Existing Sound Level (2009)**
- 0 - 65 (dBA)
 - 66 - 80 (dBA)
 - Noise level above noise abatement criteria
- Change in Sound Level from Existing (2030 No Build and Preferred Alternative)**
- ▼ -10 to -13 (dBA) decrease and noise level below noise abatement criteria
 - ▼ -7 to -9 (dBA) decrease and noise level below noise abatement criteria
 - ▼ -3 to -6 (dBA) decrease and noise level below noise abatement criteria
 - ▲ Noticeable increase and noise level below noise abatement criteria
 - No noticeable change and noise level below noise abatement criteria
 - Noticeable decrease and noise level above noise abatement criteria
 - No noticeable change and noise level above noise abatement criteria
 - ▲ 3 to 6 (dBA) increase and noise level above noise abatement criteria
 - ▲ 7 to 9 (dBA) increase and noise level above noise abatement criteria
- 4-foot noise absorptive traffic barrier
 - Pavement

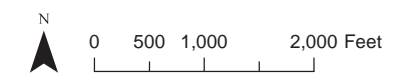

Sources: King County (2005) GIS Data (Streets), King County (2007) GIS Data (Water Bodies). Horizontal datum for all layers is NAD83(91); vertical datum for layers is NAVD88.



Exhibit 27. Sound Level Changes in the Study Area without Mitigation
I-5 to Medina: Bridge Replacement and HOV Project

For the purposes of describing the noise-level changes, the 2030 Preferred Alternative peak-hour traffic noise levels are compared to the existing and 2030 No Build Alternative peak-hour traffic noise levels. The exhibits show the noise modeling sites, note which receivers approach or exceed the NAC, and provide a symbol indicating whether a person with average hearing would notice an increase, decrease, or no change in traffic noise. Noise levels would be reduced by 3 dBA L_{eq} or more at locations where there would be a noticeable decrease in noise levels. Conversely, noise levels would increase by 3 dBA L_{eq} or more at receivers where there would be a noticeable increase in traffic noise. Noise levels at locations shown as having no noticeable change would remain within 2 dBA L_{eq} of current levels.

Potential Effects of the Project Alternatives on Neighborhoods in the Study Area

This section describes the relative audible differences for each neighborhood in the study area. The focus is on where traffic noise levels would approach or exceed the NAC and on the noise-level differences between existing conditions and the 2030 No Build Alternative and the 2030 Preferred Alternative.

Portage Bay/Roanoke

With the Preferred Alternative, fewer receivers would approach or exceed the NAC compared to the No Build Alternative noise levels due to noise-reducing effects of the 10th Avenue East/Delmar Drive East lid, the 4-foot tall concrete traffic barriers with noise-absorptive materials, and the lower posted speed limit of 45 mph across the Portage Bay structure. Twenty-two residences would approach or exceed the NAC under the Preferred Alternative compared to 24 residences with the No Build Alternative.

Portage Bay/Roanoke without Noise Mitigation		
Number of Residences Where Noise Levels Would Approach or Exceed NAC		
Current	No Build Alternative	Preferred Alternative
24	24	22

Exhibit 28 provides tabulated TNM results that compare the Preferred Alternative peak-hour traffic noise levels with the 2030 No Build Alternative and current peak-hour traffic noise levels for the Portage Bay/Roanoke neighborhood.

North Capitol Hill

With the Preferred Alternative, fewer receivers would approach or exceed the NAC compared to the No Build Alternative noise levels due to noise-reducing effects of the 10th Avenue East/Delmar Drive East lid, the 4-foot tall concrete traffic barriers with noise-absorptive materials, and the lower posted speed limit of 45 mph across the Portage Bay structure. Forty-four residences would approach or exceed the NAC under the Preferred Alternative compared to 101 residences with the No Build Alternative.

North Capitol Hill without Noise Mitigation		
Number of Residences Where Noise Levels Would Approach or Exceed NAC		
Current	No Build Alternative	Preferred Alternative
99	101	44



Exhibit 28. Preferred Alternative 2030 Peak-Hour Traffic Noise Levels for Portage Bay/Roanoke

Receiver Number	Residences or Residential Equivalents	NAC	Current ^{a,b}	No Build Alternative ^{a,b}	Preferred Alternative ^{a,b}
HR-1	4	66	77	78	78
HR-2	4	66	75	76	75
HR-3	2	66	72	73	71
HR-4	3	66	66	66	66
HR-5	3	66	67	67	70
HR-6	1	66	75	75	– ^c
HR-7	2	66	64	65	60
HR-8	1	66	62	64	59
HR-9	1	66	68	67	58
HR-10	4	66	63	63	61
HR-11	4	66	56	56	61
HR-12	4	66	63	64	64
HR-13	5	66	64	65	64
HR-14	3	66	67	67	67
HR-15	3	66	74	73	74
HR-16	1	66	64	65	64
HR-17	3	66	63	64	63
HR-18	4	66	61	61	62
HR-19	4	66	61	61	59
HR-20	4	66	60	60	58
HR-21	3	66	58	57	58
HR-22	5	66	63	63	57
HR-23	6	66	61	61	58
BH-1	3	66	63	63	57
BH-2	3	66	64	64	58
BH-3	3	66	62	62	57

^a All noise levels in the exhibit are L_{eq} in dBA.

^b Bold numbers throughout the exhibit indicate noise levels that approach within 1 dBA or exceed the NAC of 67 dBA L_{eq} .

^c This receiver would be displaced by the Preferred Alternative.



Exhibit 29 provides tabulated TNM results that compare the Preferred Alternative peak-hour traffic noise levels with the 2030 No Build Alternative and current peak-hour traffic noise levels for North Capitol Hill. Previously in the SDEIS analysis, CH-6 was used to represent 18 residential apartment units. For the Preferred Alternative, CH-6 was split into two separate receivers (CH-6 Upper and CH-6 Lower) to better account for differing traffic noise effects that could be expected at the upper floors of the multistory complex versus the lower floors.

Exhibit 29. Preferred Alternative 2030 Peak-Hour Traffic Noise Levels for North Capitol Hill

Receiver Number	Residences or Residential Equivalents	NAC	Current ^{a,b}	No Build Alternative ^{a,b}	Preferred Alternative ^{a,b}
CH-1	3	66	73	73	72
CH-2	2	66	71	71	73
CH-3	4	66	66	66	62
CH-4	4	66	64	65	63
CH-5	2	66	65	66	65
CH-6 Upper	9	66	72	72	66
CH-6 Lower	9	66	72	72	62
CH-7	4	66	68	68	59
CH-8	24	66	67	66	60
CH-9	8	66	67	66	60
CH-10	1	66	64	64	63
CH-11	3	66	63	63	62
CH-12	8	66	65	65	65
CH-13	6	66	69	69	69
CH-14	5	66	65	65	64
CH-15	6	66	66	66	65
CH-16	20	66	66	67	67
CH-17	6	66	63	63	63
CH-18	4	66	62	63	61
CH-19	2	66	63	63	61
CH-20	4	66	63	63	60
CH-21	14	66	64	64	58
CH-22	16	66	64	64	58
CH-23	8	66	64	64	58
CH-24	14	66	62	62	58



Exhibit 29. Preferred Alternative 2030 Peak-Hour Traffic Noise Levels for North Capitol Hill

Receiver Number	Residences or Residential Equivalents	NAC	Current ^{a,b}	No Build Alternative ^{a,b}	Preferred Alternative ^{a,b}
CH-25	6	66	63	62	60
CH-26	7	66	62	62	60
CH-27	6	66	62	62	60
CH-28	4	66	69	71	69
CH-29	3	66	61	61	60
CH-30	5	66	61	60	59
CH-31	1	66	60	60	58
CH-32	1	66	61	61	59

^a All noise levels in the exhibit are L_{eq} in dBA.

^b Bold numbers throughout the exhibit indicate noise levels that approach within 1 dBA or exceed the NAC of 67 dBA L_{eq} .

Montlake North of SR 520

With the Preferred Alternative, fewer receivers would approach or exceed the NAC compared to the No Build Alternative noise levels due to noise-reducing effects of the Montlake lid, shifts in the project roadway alignments, and the 4-foot tall concrete traffic barriers with noise-absorptive materials. Twenty-eight residences would approach or exceed the NAC under the Preferred Alternative compared to 42 residences with the No Build Alternative.

Montlake North of SR 520 without Noise Mitigation		
Number of Residences Where Noise Levels Would Approach or Exceed NAC		
Current	No Build Alternative	Preferred Alternative
37	42 ^a	28

^a The number of residences is rounded to the nearest whole number. The actual number of residential equivalents is 41.667.

Exhibit 30 provides tabulated TNM results that compare the Preferred Alternative peak-hour traffic noise levels with the 2030 No Build Alternative and current peak-hour traffic noise levels for Montlake North of SR 520.

Montlake South of SR 520

With the Preferred Alternative, fewer receivers would approach or exceed the NAC compared to the No Build Alternative noise levels due to noise-reducing effects of the Montlake lid, shifts in the project roadway alignments, and the 4-foot concrete traffic barriers with noise-absorptive materials. Thirty-nine residences would approach or exceed the NAC under the Preferred Alternative compared to 67 residences with the No Build Alternative.

Montlake South of SR 520 without Noise Mitigation		
Number of Residences Where Noise Levels Would Approach or Exceed NAC		
Current	No Build Alternative	Preferred Alternative
63	67 ^a	39

^a The number of residences is rounded to the nearest whole number. The actual number of residential equivalents is 66.5.



Exhibit 30. Preferred Alternative 2030 Peak-Hour Traffic Noise Levels for Montlake North of SR 520

Receiver Number	Residences or Residential Equivalents	NAC	Current ^{a,b}	No Build Alternative ^{a,b}	Preferred Alternative ^{a,b}
MN-1	3.3 ^c	66	69	67	62
MN-2	3.3 ^c	66	66	67	64
MN-3	0	— ^d	75 ^d	— ^d	— ^d
MN-4	2	66	67	67	61
MN-5	3	66	67	67	62
MN-6	3	66	66	68	67
MN-7	2	66	69	74	73
MN-8	3	66	68	71	72
MN-9	3	66	64	66	65
MN-10	4	66	64	64	62
MN-11	3.3 ^c	66	66	65	61
MN-12	3.3 ^c	66	65	64	60
MN-13	4	66	64	63	60
MN-14	3	66	64	63	61
MN-15	4	66	64	63	62
MN-16	4	66	63	64	64
MN-17	4	66	68	70	73
MN-18	3	66	72	73	72
MN-19	5	66	62	65	64
MN-20	3	66	60	64	62
MN-21	3	66	61	63	61
MN-22	3.3 ^c	66	63	63	60
MN-23	4	66	68	70	72
MN-24	3	66	62	62	59
MN-25	2	66	63	66	65
MN-26	2	66	72	68	71
MN-27	3	66	65	65	66
MN-28	6	66	60	61	62
MN-29	3.3 ^c	66	65	64	62
MN-30	3.3 ^c	66	60	60	60
MN-31	4	66	59	60	61



Exhibit 30. Preferred Alternative 2030 Peak-Hour Traffic Noise Levels for Montlake North of SR 520

Receiver Number	Residences or Residential Equivalents	NAC	Current ^{a,b}	No Build Alternative ^{a,b}	Preferred Alternative ^{a,b}
MN-32	2	66	62	64	65
MN-33	1	66	64	66	67
MN-34	1	66	66	72	69
MN-35	2	66	63	68	67

^a All noise levels in the exhibit are L_{eq} in dBA.

^b Bold numbers throughout the exhibit indicate noise levels that approach within 1 dBA or exceed the NAC of 67 dBA L_{eq} .

^c Includes residential equivalents for outside activity areas in McCurdy Park and East Montlake Park, represented by this receiver. These areas include The residential equivalents calculation is displayed to the tenths of a decimal.

^d This receiver (MN-3) is near the existing SR 520 alignment and was used only to aid in model verification. Because it is not a location representing a noise-sensitive property, the NAC does not apply. Under the Preferred Alternative, MN-3 would be displaced with the new project alignment and is not carried through the rest of this report.

Exhibit 31 provides tabulated TNM results that compare the Preferred Alternative peak-hour traffic noise levels with the 2030 No Build Alternative and current peak-hour traffic noise levels for Montlake South of SR 520.

Exhibit 31. Preferred Alternative 2030 Peak-Hour Traffic Noise Levels for Montlake South of SR 520

Receiver Number	Residences or Residential Equivalents	NAC	Current ^{a,b}	No Build Alternative ^{a,b}	Preferred
MS-1	4	66	74	75	75
MS-2	4	66	74	73	70
MS-3	6	66	74	72	67
MS-4	3	66	72	70	68
MS-5	5	66	70	68	67
MS-6	4	66	59	58	59
MS-7	4	66	59	58	59
MS-8	3	66	61	61	62
MS-9	2	66	62	64	65
MS-10	4	66	67	70	70
MS-11	2	66	60	62	62
MS-12	4	66	56	57	58
MS-13	4	66	58	56	58
MS-14	4	66	60	59	59
MS-15	6	66	56	56	58
MS-16	4	66	62	62	63
MS-17	2	66	73	72	72



Exhibit 31. Preferred Alternative 2030 Peak-Hour Traffic Noise Levels for Montlake South of SR 520

Receiver Number	Residences or Residential Equivalents	NAC	Current ^{a,b}	No Build Alternative ^{a,b}	Preferred Alternative ^{a,b}
MS-18	4	66	65	69	70
MS-19	4	66	66	67	66
MS-20	3	66	66	66	66
MS-21	9.2 ^c	66	70	69	62
MS-22	9.2 ^c	66	69	68	60
MS-23	9.2 ^c	66	66	66	59
MS-24	2	66	63	63	58
MS-25	2	66	63	63	58
MS-26	4	66	63	56	56
MS-27	3	66	65	65	62
MS-28	4	66	64	65	63
MS-29	4	66	63	63	63
MS-30	4	66	64	65	65
MS-31	6	66	58	56	58
MS-32	4	66	61	59	60
MS-33	5	66	64	62	63

^a All noise levels in the exhibit are L_{eq} in dBA.

^b Bold numbers throughout the exhibit indicate noise levels that approach within 1 dBA or exceed the NAC of 67 dBA L_{eq} .

^c Includes residential equivalents for outside activity areas in Montlake Playfield represented by this receiver. The residential equivalents calculation is displayed to the tenths of a decimal.

University of Washington

With the Preferred Alternative, the same receivers would approach or exceed the NAC compared to the No Build Alternative noise levels. Four residential equivalents would approach or exceed the NAC under the Preferred Alternative and the No Build Alternative.

Exhibit 32 provides tabulated TNM results that compare the Preferred Alternative peak-hour traffic noise levels with the 2030 No Build Alternative and current peak-hour traffic noise levels for the University of Washington.

University of Washington without Noise Mitigation		
Number of Residences Where Noise Levels Would Approach or Exceed NAC		
Current	No Build Alternative	Preferred Alternative
2	4 ^a	4 ^a

^a The number of residences is rounded to the nearest whole number. The actual number of residential equivalents is 4.46.



Exhibit 32. Preferred Alternative 2030 Peak-Hour Traffic Noise Levels for the University of Washington

Receiver Number	Residences or Residential Equivalents	NAC	Current ^{a,b}	No Build Alternative ^{a,b}	Preferred Alternative ^{a,b}
UW-1	2.2 ^c	66	65	68	69
UW-2	2.2 ^c	66	58	61	62
UW-3	2.2 ^c	66	55	57	58
UW-4	2.2 ^c	66	54	56	56
UW-5	11.2 ^c	66	54	56	57
UW-6	3.3 ^c	66	58	60	60
UW-7	5.6 ^c	66	62	64	63
UW-8	5.6 ^c	66	52	55	55
UW-9	22.3 ^c	66	53	56	56
UW-10	5.6 ^c	66	62	65	65
UW-11	2.2 ^c	66	66	68	68
UW-12	2.2 ^c	66	64	65	65
UW-13	5.4 ^c	66	59	62	62
UW-14	2.7 ^c	66	61	65	65
UW-15	2.2 ^c	66	64	65	65
UW-16	5.6 ^c	66	62	62	63

^a All noise levels in the exhibit are L_{eq} in dBA.

^b Bold numbers throughout the exhibit indicate noise levels that approach within 1 dBA or exceed the NAC of 67 dBA L_{eq} .

^c Includes residential equivalents for outside activity areas represented by this receiver. These exterior areas include open space within the University of Washington campus, inside and around the Husky Stadium, outside the University Hospital, and areas outside classrooms. The residential equivalents calculation is displayed to the tenths of a decimal.

Washington Park Arboretum

With the Preferred Alternative, fewer receivers would approach or exceed the NAC compared to the No Build Alternative noise levels due to noise-reducing effects of the Montlake lid, shifts in the project roadway alignments, elimination of the SR 520 Westbound off-ramp and Eastbound on-ramp through this area, and the inclusion of the 4-foot tall concrete traffic barriers with noise-absorptive materials. Five residential equivalents would approach or exceed the NAC under the Preferred Alternative compared to 22 with the No Build Alternative.

Washington Park Arboretum without Noise Mitigation

Number of Residences Where Noise Levels Would Approach or Exceed NAC

Existing	No Build Alternative	Preferred Alternative
22	22 ^a	5 ^b

^a The number of residences is rounded to the nearest whole number. The actual number of residential equivalents is 21.6.

^b The number of residences is rounded to the nearest whole number. The actual number of residential equivalents is 5.4.



Exhibit 33 provides tabulated TNM results that compare the Preferred Alternative peak-hour traffic noise levels with the 2030 No Build Alternative and current peak-hour traffic noise levels for the Washington Park Arboretum.

Exhibit 33. Preferred Alternative 2030 Peak-Hour Traffic Noise Levels for the Washington Park Arboretum

Receiver Number	Residences or Residential Equivalents	NAC	Current ^{a,b}	No Build Alternative ^{a,b}	Preferred Alternative ^{a,b}
AB-1	5.4 ^c	66	66	65	61
AB-2	5.4 ^c	66	67	66	62
AB-3	5.4 ^c	66	68	68	62
AB-4	0 ^d	66	80	82	-- ^e
AB-5	0 ^d	66	76	79	-- ^e
AB-6	0 ^d	66	72	74	61
AB-7	0 ^d	66	70	72	62
AB-8	0 ^d	66	69	71	62
AB-9	0 ^d	66	68	70	63
AB-10	0 ^d	66	67	69	63
AB-11	0 ^d	66	67	68	63
AB-12	0 ^d	66	66	67	63
AB-13	0 ^d	66	65	67	63
AB-14	5.4 ^c	66	63	64	62
AB-15	5.4 ^c	66	71	72	66
AB-16	5.4 ^c	66	65	66	64
AB-17	5.4 ^c	66	60	61	60
AB-18	5.4 ^c	66	56	56	55
AB-19	5.4 ^c	66	64	62	58
AB-20	5.4 ^c	66	63	62	62

^a All noise levels in the exhibit are L_{eq} in dBA.

^b Bold numbers throughout the exhibit indicate noise levels that approach within 1 dBA or exceed the NAC of 67 dBA L_{eq} .

^c Includes residential equivalents for outside activity areas within the Arboretum represented by this receiver. The residential equivalents calculation is displayed to the tenths of a decimal.

^d This receiver was used only to validate the noise model and to determine the distance from SR 520 to where the NAC of 67 dBA L_{eq} would be approached or exceeded.

^e Receiver to be displaced by project footprint; modeling location no longer valid for Preferred Alternative.



Madison Park

With the Preferred Alternative, no receivers would approach or exceed the NAC compared to the 16 residences that would approach or exceed the NAC with the No Build Alternative. The lower noise levels within Madison Park would be due to noise-reducing effects of shifts in the project roadway alignments and the 4-foot tall concrete traffic barriers with noise-absorptive materials.

Madison Park without Noise Mitigation		
Number of Residences Where Noise Levels Would Approach or Exceed NAC		
Current	No Build Alternative	Preferred Alternative
16	16	0

Exhibit 34 provides tabulated TNM results that compare the Preferred Alternative peak-hour traffic noise levels with the 2030 No Build Alternative and current peak-hour traffic noise levels for Madison Park.

Exhibit 34. Preferred Alternative 2030 Peak-Hour Traffic Noise Levels for Madison Park

Receiver Number	Residences or Residential Equivalents	NAC	Current ^{a,b}	No Build Alternative ^{a,b}	Preferred Alternative ^{a,b}
MP-1	3	66	66	66	62
MP-2	2	66	67	67	62
MP-3	2	66	68	68	62
MP-4	3	66	69	69	63
MP-5	3	66	66	66	62
MP-6	2	66	63	63	61
MP-7	3	66	61	61	59
MP-8	3	66	60	60	57
MP-9	4	66	61	61	58
MP-10	16.7 ^c	66	61	61	59
MP-11	16.7 ^c	66	61	61	59
MP-12	4	66	59	59	57
MP-13	3	66	60	60	59
MP-14	4	66	61	61	59
MP-15	4	66	61	61	59
MP-16	4	66	63	63	61
MP-17	3	66	64	64	62
MP-18	5	66	65	65	62
MP-19	3	66	66	66	64
MP-20	3	66	64	64	63



Exhibit 34. Preferred Alternative 2030 Peak-Hour Traffic Noise Levels for Madison Park

Receiver Number	Residences or Residential Equivalents	NAC	Current ^{a,b}	No Build Alternative ^{a,b}	Preferred Alternative ^{a,b}
MP-21	1	66	60	60	58
MP-22	4	66	58	59	56
MP-23	3	66	57	56	56

^a All noise levels in the exhibit are L_{eq} in dBA.

^b Bold numbers throughout the exhibit indicate noise levels that approach within 1 dBA or exceed the NAC of 67 dBA L_{eq} .

^c Includes residential equivalents for outside activity areas at the Broadmoor Golf Club represented by this receiver. . The residential equivalents calculation is displayed to the tenths of a decimal.

Laurelhurst

With the Preferred Alternative, no receivers would approach or exceed the NAC, which is the same result determined with the No Build Alternative.

Exhibit 35 provides tabulated TNM results that compare the Preferred Alternative peak-hour traffic noise levels with the 2030 No Build Alternative and current peak-hour traffic noise levels for Laurelhurst.

Laurelhurst without Noise Mitigation		
Number of Residences Where Noise Levels Would Approach or Exceed NAC		
Current	No Build Alternative	Preferred Alternative
0	0	0

Exhibit 35. Preferred Alternative 2030 Peak-Hour Traffic Noise Levels for Laurelhurst

Receiver Number	Residences or Residential Equivalents	NAC	Current ^{a,b}	No Build Alternative ^{a,b}	Preferred Alternative ^{a,b}
LH-1	2	66	61	61	60
LH-2	2	66	60	61	59
LH-3	2	66	59	60	59
LH-4	2	66	60	60	59
LH-5	2	66	53	56	55
LH-6	3	66	57	57	56
LH-7	2	66	51	56	53

^a All noise levels in the exhibit are L_{eq} in dBA.

^b Bold numbers throughout the exhibit indicate noise levels that approach within 1 dBA or exceed the NAC of 67 dBA L_{eq} .

Medina North of SR 520

Since the preparation of the SDEIS, several homes have been removed on the north side of SR 520 between Lake Washington and 76th Avenue NE, requiring a reevaluation of noise modeling sites used in this area. Updated receiver locations were selected based on site visits and review of the complex topographical conditions using aerial maps. On the north side of SR 520, 19 residences were



identified and are designated PN (LPA)-1 through PN (LPA)-19. Exhibit 26 shows the location of the Medina North of SR 520 area receivers. Some important changes include:

- Noise receivers M43 and M45 are now undeveloped lands, and therefore the noise modeling receivers for these two locations (PN-3 and PN-5) are no longer used
- Site PA-LPA-1 is approximately the same as the previous site PN-1/M40, corrected to better represent the sensitive use at this property
- Site PN-LPA-17 is approximately the same as the previous site PN-9/M46, corrected to better represent the sensitive use at this property
- All other sites were selected based on site visits and aerial mapping with the Preferred Alternative design

With the Preferred Alternative, one additional residence would approach or exceed the NAC compared to the No Build Alternative noise levels. Five residences would approach or exceed the NAC under the Preferred Alternative compared to four with the No Build Alternative.

Exhibit 36 provides tabulated TNM results that compare the Preferred Alternative peak-hour traffic noise levels with the 2030 No Build Alternative and current peak-hour traffic noise levels for Medina north of SR 520.

Medina North of SR 520 without Noise Mitigation		
Number of Residences Where Noise Levels Would Approach or Exceed NAC		
Current	No Build Alternative	Preferred Alternative
1	4	5

Exhibit 36. Preferred Alternative 2030 Peak-Hour Traffic Noise Levels for Medina North of SR 520

Receiver Number	Residences or Residential Equivalents	NAC	Current ^{a,b}	No Build Alternative ^{a,b}	Preferred Alternative ^{a,b}
PN(LPA)-1	1	66	68	68	58 ^C
PN(LPA)-2	1	66	65	66	70
PN(LPA)-3	1	66	65	66	70
PN(LPA)-4	1	66	63	64	61
PN(LPA)-5	1	66	60	61	65
PN(LPA)-6	1	66	61	62	64
PN(LPA)-7	1	66	65	66	61
PN(LPA)-8	1	66	59	60	64
PN(LPA)-9	1	66	61	61	62
PN(LPA)-10	1	66	62	63	67
PN(LPA)-11	1	66	64	64	68



Exhibit 36. Preferred Alternative 2030 Peak-Hour Traffic Noise Levels for Medina North of SR 520

Receiver Number	Residences or Residential Equivalents	NAC	Current ^{a,b}	No Build Alternative ^{a,b}	Preferred Alternative ^{a,b}
PN(LPA)-12	1	66	63	64	69
PN(LPA)-13	1	66	59	60	62
PN(LPA)-14	1	66	60	60	64
PN(LPA)-15	1	66	57	58	61
PN(LPA)-16	1	66	56	57	53
PN(LPA)-17	1	66	56	57	61
PN(LPA)-18	1	66	60	61	58
PN(LPA)-19	1	66	58	58	54

^a All noise levels in the exhibit are L_{eq} in dBA.

^b Bold numbers throughout the exhibit indicate noise levels that approach within 1 dBA or exceed the NAC of 67 dBA L_{eq} .

^c This receiver would be well within the noise shadow zone created by the proposed elevated SR 520 roadway which explains the lower noise levels under the Preferred Alternative compared to the existing and No Build conditions.

Medina South of SR 520

As performed for Medina north of SR 520, the area south of SR 520 was also re-evaluated and an updated list of existing residential land uses was prepared. On the south side of SR 520, 18 residences were identified and are designated PS (LPA)-1 through PN (LPA)-18. Notable changes for this area include:

- Receiver site PS-LPA-2 replaces PS-2/M42
- Receiver site PS-LPA-5 replaces PS-23/M41, and was moved slightly east to better represent the frequent exterior use at this residence
- Receiver site PS-LPA-3 replaces PS-3/M44, and was moved slightly east to better represent the frequent exterior use at this residence
- Two receivers, PS-LPA-17 and PS-LPA-18 were used to represent two homes previously represented by PS-25/M48
- Receiver site PS-LPA-7 replaces PS-5/M48, and was moved slightly east to better represent the frequent exterior use at this residence
- All other sites were selected based on site visits and aerial mapping with the Preferred Alternative design

With the Preferred Alternative, fewer receivers would approach or exceed the NAC compared to the No Build Alternative noise levels due to noise-reducing effects of the Evergreen Point Road lid and shifts in the project roadway alignments. Exhibit 26 shows the location of the Medina South of



SR 520 area receivers. Two residences would approach or exceed the NAC under the Preferred Alternative compared to eight with the No Build Alternative. The proposed project alignment would relocate SR 520 away from many of the receivers, which explains the lower noise levels under the build condition, compared to the existing and No Build conditions.

Medina South of SR 520 without Noise Mitigation		
Number of Residences Where Noise Levels Would Approach or Exceed NAC		
Current	No Build Alternative	Preferred Alternative
7	8	2

Exhibit 37 provides tabulated TNM results that compare the Preferred Alternative peak-hour traffic noise levels with the 2030 No Build Alternative and current peak-hour traffic noise levels for Medina south of SR 520.

Exhibit 37. Preferred Alternative 2030 Peak-Hour Traffic Noise Levels for Medina South of SR 520

Receiver Number	Residences or Residential Equivalents	NAC	Current ^{a,b}	No Build Alternative ^{a,b}	Preferred Alternative ^{a,b}
PS (LPA)-1	1	66	70	70	59
PS (LPA)-2	1	66	67	68	61
PS (LPA)-3	1	66	69	70	67
PS (LPA)-4	1	66	73	74	68
PS (LPA)-5	1	66	65	66	59
PS (LPA)-6	1	66	66	67	64
PS (LPA)-7	1	66	66	67	63
PS (LPA)-8	1	66	67	68	62
PS (LPA)-9	1	66	64	64	63
PS (LPA)-10	1	66	63	64	57
PS (LPA)-11	1	66	60	61	59
PS (LPA)-12	1	66	62	63	62
PS (LPA)-13	1	66	62	63	62
PS (LPA)-14	1	66	63	63	62
PS (LPA)-15	1	66	61	62	56
PS (LPA)-16	1	66	59	60	60
PS (LPA)-17	1	66	61	61	60
PS (LPA)-18	1	66	59	60	60

^a All noise levels in the exhibit are L_{eq} in dBA.

^b Bold numbers throughout the exhibit indicate noise levels that approach within 1 dBA or exceed the NAC of 67 dBA L_{eq}.



Noise Abatement

What has been done to avoid or minimize negative effects from noise?

Several design elements and general corridor improvements were added to the project resulting from the SR 520 Noise Expert Review Panel and in response to community input. The Preferred Alternative design includes 4-foot tall concrete traffic barriers with noise-absorptive materials along both sides of the SR 520 between I-5 and the west transition span, including the west approach bridge through the Arboretum. The median planter on the Portage Bay Bridge will also be constructed to include noise absorptive materials. The noise-reducing effects of the 4-foot barriers and planters were included in the traffic noise model; however, noise absorptive materials were not included in the model. Exhibit 38 provides plan and profile views of the proposed 4-foot tall concrete traffic barriers with noise-absorptive materials in the I-5 to west approach area.

It was also concluded that the 4-foot barriers and planters would aid in lowering the number of residences or residential equivalents where noise levels would approach or exceed the traffic noise abatement criteria along the project alignment compared to the results found in the previous analyses, which did not include 4-foot tall concrete traffic barriers with noise-absorptive materials. The additional 1 to 2 dBA reduction that may be provided by installing acoustically absorptive barriers is not included in the results presented in this report. The final design element, which includes expanding the Montlake lid to cover a larger portion of SR 520, would also result in lower traffic noise level projections near the lid compared to alignment designs considered in previous analyses.

Additionally, within the corridor along the Portage Bay Bridge between I-5 and the Montlake lid, the posted speeds would be reduced to 45 mph, which also aids in lowering the traffic noise levels within this area. Modifying speed limits is one of the abatement measures that can be considered under WSDOT policy and, typically, a reduction in traffic noise of up to 3 dBA can be expected with a speed reduction of 10 mph. The combined effect of the design elements discussed above and the noise abatement from the reduced speed limit would result in overall lower noise levels along the project alignment, when compared to project construction without the barriers. However, there would continue to be project-related noise effects and, therefore, noise abatement measures must be considered under WSDOT policy. As described in the 2009 Noise Discipline Report section “What has been done to avoid or minimize negative effects from noise?” (see page 107), after reducing the speed limit, noise walls were determined to be the only other viable noise abatement option for the remaining noise-affected residences after the project design elements were accounted for.



Alternative Noise-Reducing Design Elements

In addition to the 4-foot tall concrete traffic barriers with noise-absorptive materials and lower speed limits, the project team is currently evaluating using some form of quieter concrete pavement. The FHWA noise program policy related to tire/pavement noise (FHWA 2005) reads as follows:

“Pavement is sometimes mentioned as a factor in traffic noise. While it is true that noise levels do vary with changes in pavements and tires, it is not clear that these variations are substantial when compared to the noise from exhausts and engines, especially when there are a large number of trucks on the highway. Additional research is needed to determine to what extent different types of pavements and tires contribute to traffic noise.



It is very difficult to forecast pavement surface condition into the future. Unless definite knowledge is available on the pavement type and condition and its noise generating characteristics, no adjustments should be made for pavement type in the prediction of highway traffic noise levels. Studies have shown open-graded asphalt pavement can initially produce a benefit of 2-4 dBA reduction in noise levels. However, within a short time period (approximately 6-12 months), any noise reduction benefit is lost when the voids fill up and the aggregate becomes polished. The use of specific pavement types or surface textures must not be considered as a noise abatement measure.”

The FHWA policy restricts making adjustments for pavement type in the prediction of highway traffic noise levels and using specific pavement types or surface textures as noise abatement measures.

Sound measurements along the SR 520 corridor performed after three different types of quieter asphalt pavement were installed have been consistent between test sections. Any audible reductions in the test pavements were gone after about 6 months. In general, the asphalt testing did not produce a pavement type that meets all WSDOT criteria; however, WSDOT is committed to continuing to test other types of pavements and is committed to using a pavement type that will meet overall pavement standards for state highways. Currently, there is no guarantee that the pavement used in the SR 520 corridor will be any quieter in the long-term than standard pavement types currently in use by WSDOT.

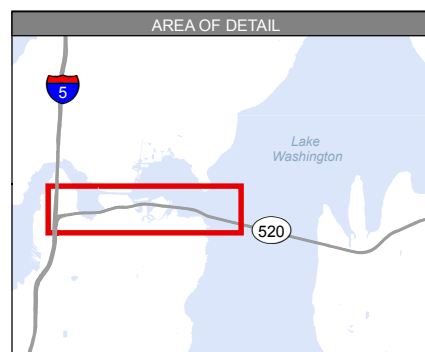
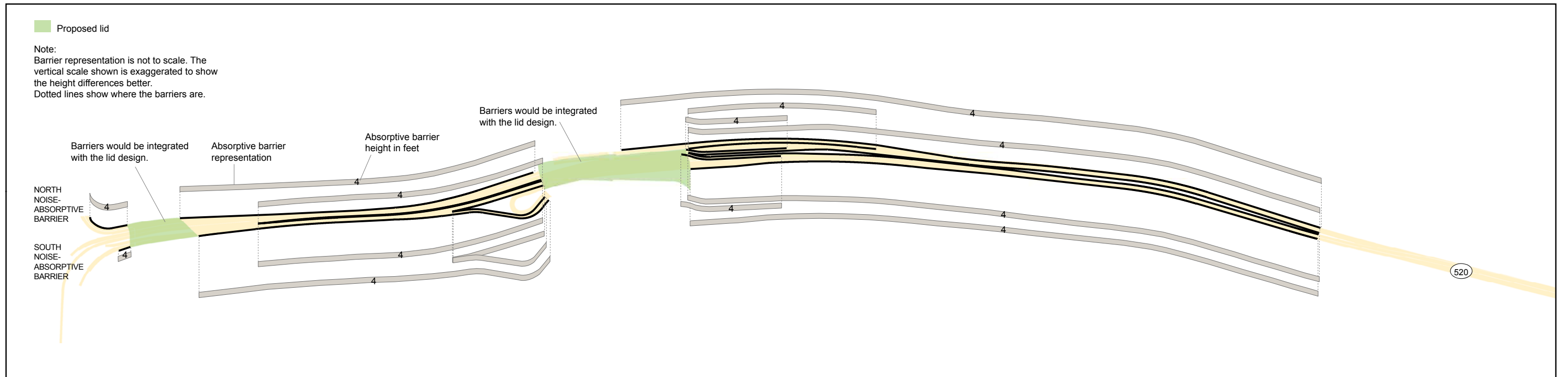



-  4-foot Noise-absorptive Traffic Barrier Included as part of the Preferred Alternative Project Design
-  Pavement

Note: The 4-foot noise-absorptive traffic barriers shown in this exhibit are part of the Preferred Alternative design and, although not designated as a mitigation measure, do have noise-reducing benefits and are, therefore, shown for reference only.

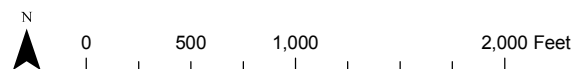

Source: King County (2006) aerial photo. Horizontal datum for all layers is NAD83(91); vertical datum for layers is NAVD88.



Exhibit 38. Locations of 4-foot Tall Concrete Traffic Barriers with Noise Absorptive Materials for the Preferred Alternative in the I-5 to West Approach Area

SR 520, I-5 to Medina: Bridge Replacement and HOV Project

What noise walls are recommended for the Preferred Alternative?

The Preferred Alternative peak-hour traffic noise levels with noise walls represent the worst-case traffic noise levels that could be expected with 2030 traffic flow conditions if the recommended noise walls were constructed.

Noise walls were considered for each of the noise-affected residences after accounting for the noise reducing effects of the 4-foot concrete traffic barrier under the Preferred Alternative. Overall, the Preferred Alternative with recommended noise walls would lower the number of residences and residential equivalents where noise levels would approach or exceed the NAC from 150 to 143 residences. The number of residences that would approach or exceed the NAC under the No Build Alternative would be 287 residences and residential equivalents.

Exhibits 21 through 26 show the receiver locations and modeled noise levels. For each receiver, the existing, 2030 No Build Alternative, and 2030 Preferred Alternative peak-hour noise levels are shown in these exhibits. To illustrate how effective the recommended noise walls within the Medina neighborhood would be at reducing traffic noise levels under the Preferred Alternative, noise levels with and without the recommended noise walls are shown for each receiver location.

The Preferred Alternative with the recommended noise walls would meet the following noise abatement objectives:

1. Reduce the overall noise levels for at least one residence by 7 dBA
2. Achieve a noise reduction of at least 5 dBA at 60 percent of frontline residences
3. Where possible, reduce the noise levels at all residences to below the NAC of 67 dBA L_{eq}
4. Where possible, provide an average 7 to 10 dBA L_{eq} noise reduction for frontline receivers adjacent to SR 520

A 3-dBA change in noise level is normally perceived as a barely noticeable change. The 3-dBA change is a useful metric for noticeable change when comparing the 2030 No Build Alternative and the 2030 Preferred Alternative noise levels. When considering how effective a noise wall would be at reducing noise levels, it is helpful to keep in mind that decreases of 5 dBA or more are clearly noticeable and that most people perceive reductions of 10 dBA as reducing noise to a level considered half as loud.

Noise Walls Evaluated for each Neighborhood under the Preferred Alternative

This section describes the effectiveness of the proposed traffic noise abatement measures for each neighborhood in the study area, focusing on the number of residences or residential equivalents that would benefit from the noise walls. In addition, the audible differences in traffic noise levels



between the 2030 No Build Alternative and the 2030 Preferred Alternative are presented. The noise levels stated in this section include the noise-reduction benefit from all recommended noise walls. The noise discipline analysts evaluated noise walls throughout the project area and are recommending only some of these walls. Their reasons for rejecting the remainder of the walls that were considered are provided in each case. The following sections discuss each neighborhood study area.

Portage Bay/Roanoke

Noise walls were evaluated for the 22 residences represented by HR-1, HR-2, HR-3, HR-4, HR-5, HR-14, and HR-15 that would approach or exceed the NAC without the noise walls. A noise wall constructed along the north side of East Roanoke Street would be required to reduce noise levels effectively at HR-1 through HR-4 and HR-14, but this would not be feasible due to the direct driveway accesses onto East Roanoke Street. A noise wall along SR 520 from the 10th Avenue/Delmar lid across the Portage Bay structure was evaluated for the noise effects at HR-5 but would not meet the WSDOT feasibility (noise reduction) criteria.

Portage Bay/Roanoke (No Recommended Noise Walls)		
Number of Residences Where Noise Levels Would Approach or Exceed NAC		
Current	No Build Alternative	Preferred Alternative
24	24	22

The maximum noise wall height along any roadway structure such as the Portage Bay Bridge is limited to 10 feet to allow WSDOT to conduct safety inspections under the bridge structure (see WSDOT 2009a page 120 for additional information on noise wall height limits on bridge structures).

Because HR-5 is elevated above the SR 520 roadway elevation, a noise wall higher than 10 feet would be required to achieve the noise reduction required by WSDOT feasibility criteria. Receivers near HR-5 that would have noise levels below the NAC that could benefit from a noise wall constructed for HR-5 were included in the noise wall evaluation. However, none of these nearby receivers would receive a noise reduction greater than 2 dBA. Therefore, no noise wall is recommended for the noise effects at HR-5. HR-15 noise levels would continue to be dominated by I-5 traffic noise, and a noise wall along SR 520 would not effectively mitigate the traffic noise effects on HR-15.

No noise walls are recommended for the Portage Bay/Roanoke area under the Preferred Alternative.

North Capitol Hill

Noise walls were evaluated for the 44 residences represented by CH-1, CH-2, CH-6 Upper, CH-13, CH-16, and CH-28 that would approach or exceed the NAC without the noise walls. Receivers CH-1, CH-2, and CH-28 (representing nine residences) are located between the northbound I-5 off-ramp to westbound SR 520 and 10th Avenue East. Of the two noise walls evaluated, one noise wall appears to be feasible

North Capitol Hill (No Recommended Noise Walls)		
Number of Residences Where Noise Levels Would Approach or Exceed NAC		
Current	No Build Alternative	Preferred Alternative
99	101	44



and reasonable for this area. However, there are several remaining uncertainties and considerations to address before a noise wall could be constructed in this location.

- The noise wall would need to be installed on top of an existing retaining wall. More research is needed to determine if the approximately 22-foot tall retaining wall can support a noise wall that could be up to 14 to 16 feet tall.
- The potential safety and design effects of constructing a 14- to 16-foot tall wall on top of the existing retaining wall along the eastside of northbound I-5 needs further evaluation.
- Most noise at these residences is due to noise from I-5, not from SR 520. If future Type 1 improvements occur on I-5, traffic noise abatement would be evaluated at that time.
- The noise wall would block valuable views to the west.

The combination of remaining challenges has led the project team to delay the final reasonableness determination whether to recommend constructing a noise wall in this location until final design. Cursory noise modeling was used to provide the public with a general idea of the potential effectiveness of a noise wall along Harvard Avenue East. Because available design information was preliminary at the time of this analysis, a 14- to 16-foot tall wall along Harvard Avenue East was the minimum height estimated to be feasible and reasonable, but may not be constructible for the reasons listed previously. Details on these walls, including noise reduction characteristic and reasonability calculations are provided in Attachment 6.

Montlake North of SR 520

Noise walls were evaluated for the 28 residences represented by MN-6 through MN-8, MN-17, MN-18, MN-23, MN-26, MN-27, and MN-33 through MN-35 that would approach or exceed the NAC without the noise walls. Noise walls for all affected MN receivers, except MN-6 and MN-7, were considered but were rejected due to these residences' direct access from the front of their homes to the sidewalk bordering the proposed NE Montlake Boulevard alignment. A noise wall was evaluated for MN-6, MN-7, and nearby receivers that would not have noise levels approaching or exceeding the NAC but could benefit from a noise wall constructed for MN-6 and MN-7. The noise wall with a maximum allowable height of 10 feet along most of the length and a 16-foot high section near Montlake Boulevard East would reduce noise levels by 3 dBA at MN-6 and 1 dBA at MN-7, which is not sufficient to meet the WSDOT feasibility criteria. The nearby receivers would receive noise reductions of 3 dBA or less.

No noise walls are recommended for the Montlake area north of SR 520 under the Preferred Alternative.

Montlake North of SR 520 (No Recommended Noise Walls)		
Number of Residences or Residential Equivalents Where Noise Levels Would Approach or Exceed NAC		
Current	No Build Alternative	Preferred Alternative
37	42 ^a	28

^a The number of residences is rounded to the nearest whole number. The actual number of residential equivalents is 41.6.



Montlake South of SR 520

Noise walls were evaluated for the 39 residences represented by MS-1 through MS-5, MS-10, and MS-17 through MS-20 that would approach or exceed the NAC without the noise walls. A single noise wall along Lake Washington Boulevard was considered for MS-1 and MS-2 where direct driveway access to Lake Washington Boulevard is not necessary.

However, considering the proximity of the homes to Lake Washington Boulevard and the direct access each of these homes has to the sidewalk bordering Lake Washington Boulevard, a noise wall is not considered a viable option for noise abatement. Furthermore, because these homes are shielded from SR 520 traffic noise by the Montlake lid, it is evident that the high noise levels are due to traffic on Lake Washington Boulevard and not SR 520. Therefore, a noise wall between the lid and Lake Washington Boulevard would not provide any noise reduction to these residences. A noise wall was considered but rejected for MS-3 through MS-5 due to the need for direct driveway access to Lake Washington Boulevard. A noise wall along Montlake Boulevard was considered for MS-10 and MS-17. However, the residences front Montlake Boulevard and a noise wall would close access to the proposed sidewalk access. In addition, the high traffic noise levels are due to traffic on Montlake Boulevard while SR 520 traffic noise would be shielded by the Montlake lid. A final noise wall along SR 520 and the eastbound off-ramp to Montlake Boulevard was considered for MS-18 through MS-20. The 16-foot-high noise wall would reduce noise levels by 1 dBA at MS-18 and by 2 dBA at MS-19 and MS-20, which is not sufficient to meet the WSDOT feasibility criteria. The nearby receivers would receive noise reductions of 1 dBA or less. A higher noise wall was considered in an effort to achieve the minimum reductions required by WSDOT. However, the 16-foot-high noise wall with a length of over 1,700 feet would not meet the WSDOT feasibility criteria, even if the necessary reductions were achieved. Therefore, higher noise walls are not considered a viable option for this area.

No noise walls are recommended for the Montlake area south of SR 520 under the Preferred Alternative.

Montlake South of SR 520 (No Recommended Noise Walls)		
Number of Residences or Residential Equivalents Where Noise Levels Would Approach or Exceed NAC		
Current	No Build Alternative	Preferred Alternative
63	67 ^a	39

^a The number of residences is rounded to the nearest whole number. The actual number of residential equivalents is 66.5.

University of Washington

There would be four residential equivalents represented by UW-1 and UW-11 that would approach or exceed the NAC under the Preferred Alternative. Because there are no project-related improvements north of the Pacific Street intersection near the University of Washington, no noise abatement was considered for the four identified traffic noise effects in this area.

University of Washington (No Recommended Noise Walls)		
Number of Residences or Residential Equivalents Where Noise Levels Would Approach or Exceed NAC		
Current	No Build Alternative	Preferred Alternative
2	4 ^a	4 ^b

^a The number of residences is rounded to the nearest whole number. The actual number of residential equivalents is 4.4.

^b The number of residences is rounded to the nearest whole number. The actual number of residential equivalents is 4.4.



No noise walls are recommended for the University of Washington area under the Preferred Alternative.

Washington Park Arboretum

Noise walls were evaluated for the five residential equivalents represented by AB-15 that would approach or exceed the NAC without the noise walls. The nearby receiver, AB-16, which would not have noise levels that approach or exceed the NAC but would benefit from a noise wall for AB-15, was included in the noise wall evaluation.

The noise wall constructed at the maximum allowable height of 10 feet on the bridge structure would reduce noise levels by 4 dBA at AB-15, which is not sufficient to meet the WSDOT feasibility criteria. The nearby receiver, AB-16, would also receive a noise reduction of 4 dBA.

No noise walls are recommended for the Washington Park Arboretum under the Preferred Alternative.

Washington Park Arboretum (No Recommended Noise Walls)

Number of Residences or Residential Equivalents Where Noise Levels would Approach or Exceed NAC

Current	No Build Alternative	Preferred Alternative
22	22 ^a	5 ^b

^a The number of residences is rounded to the nearest whole number. The actual number of residential equivalents is 21.6.

^b The number of residences is rounded to the nearest whole number. The actual number of residential equivalents is 5.4.

Madison Park

Under the Preferred Alternative, noise levels in Madison Park would decrease by 1 to 6 dBA from existing peak-hour noise levels due to the proposed alignment and the 4-foot tall concrete traffic barriers with noise-absorptive materials included in the project design. None of the receivers within Madison Park is expected to approach or exceed the NAC; therefore, no noise walls were considered and none is recommended for Madison Park.

Madison Park (No Recommended Noise Walls)

Number of Residences and Residential Equivalents Where Noise Levels Would Approach or Exceed NAC

Current	No Build Alternative	Preferred Alternative
16	16	0

Laurelhurst

Under the Preferred Alternative, noise levels at some locations in Laurelhurst would increase by 1 to 2 dBA from existing peak-hour noise levels. All receivers within Laurelhurst would remain below the NAC; therefore, no noise walls were considered and none is recommended for Laurelhurst.

Laurelhurst (No Recommended Noise Walls)

Number of Residences Where Noise Levels Would Approach or Exceed NAC

Current	No Build Alternative	Preferred Alternative
0	0	0



Medina

With the evaluated noise walls for the Preferred Alternative, the seven residences represented by PN (LPA)-2, PN (LPA)-3, PN (LPA)-10, PN (LPA)-11, PN (LPA)-12, PS (LPA)-3 and PS (LPA)-4 would receive noise-level reductions of 5 to 8 dBA, which is sufficient to reduce future noise levels to

Medina North & South of SR 520 with Recommended Noise Walls

Number of Residences Where Noise Levels Would Approach or Exceed NAC		
Current	No Build Alternative	Preferred Alternative
8	12	0

below the NAC and meet WSDOT noise reduction requirements. Overall, the noise wall would reduce traffic noise levels by 1 to 7 dBA L_{eq} for those residences north of SR 520, and 2 to 8 dBA for those residences south of SR 520. In addition to mitigating the two residences with noise levels that would approach or exceed the NAC without a noise wall, 13 residences south of SR 520 would benefit from the evaluated noise wall with noise reductions of 3- to 7-dBA L_{eq} . North of SR 520, a total of 15 residences would benefit from the evaluated noise wall with noise reductions of 3 to 7 dBA L_{eq} .

The two noise walls recommended for the area were mostly held to 10 feet because of wall height restrictions on structures, and the fact that much of SR 520 would be built on structures in this area. The wall segments that could be constructed over 10 feet were maximized in the model to achieve the greatest possible benefit. The WSDOT requirement of 7 dBA at one first row residence and 5 dBA reduction at the majority (60 percent) of the first row residences would be met with the wall design.

Exhibit 39 presents the results of the traffic noise and noise wall analyses in terms of relative noise-level changes that could be expected for the Medina neighborhoods in 2030, with the recommended noise walls. The exhibits show the noise modeling sites using a symbol indicating whether an average person would notice a decrease or no change in traffic noise due to the recommended noise walls. Noise levels would be reduced by 3-dBA L_{eq} or more at locations where there would be a noticeable decrease in noise levels. Noise levels at locations shown as having no noticeable change would not receive a noticeable reduction in noise levels from the recommended noise walls.

The design is further evaluated for reasonableness in the following section.

Noise Walls Recommended for the Preferred Alternative

This section describes the only noise walls evaluated and recommended for the Preferred Alternative, which are the two walls in the Medina neighborhood. The locations, heights, performance characteristics, and cost-effectiveness analyses are provided for each noise wall. Noise walls that would not meet the WSDOT feasibility criteria, discussed in the above sections, are not carried forward in this analysis because each recommended noise wall must meet both the WSDOT feasibility and reasonableness criteria.



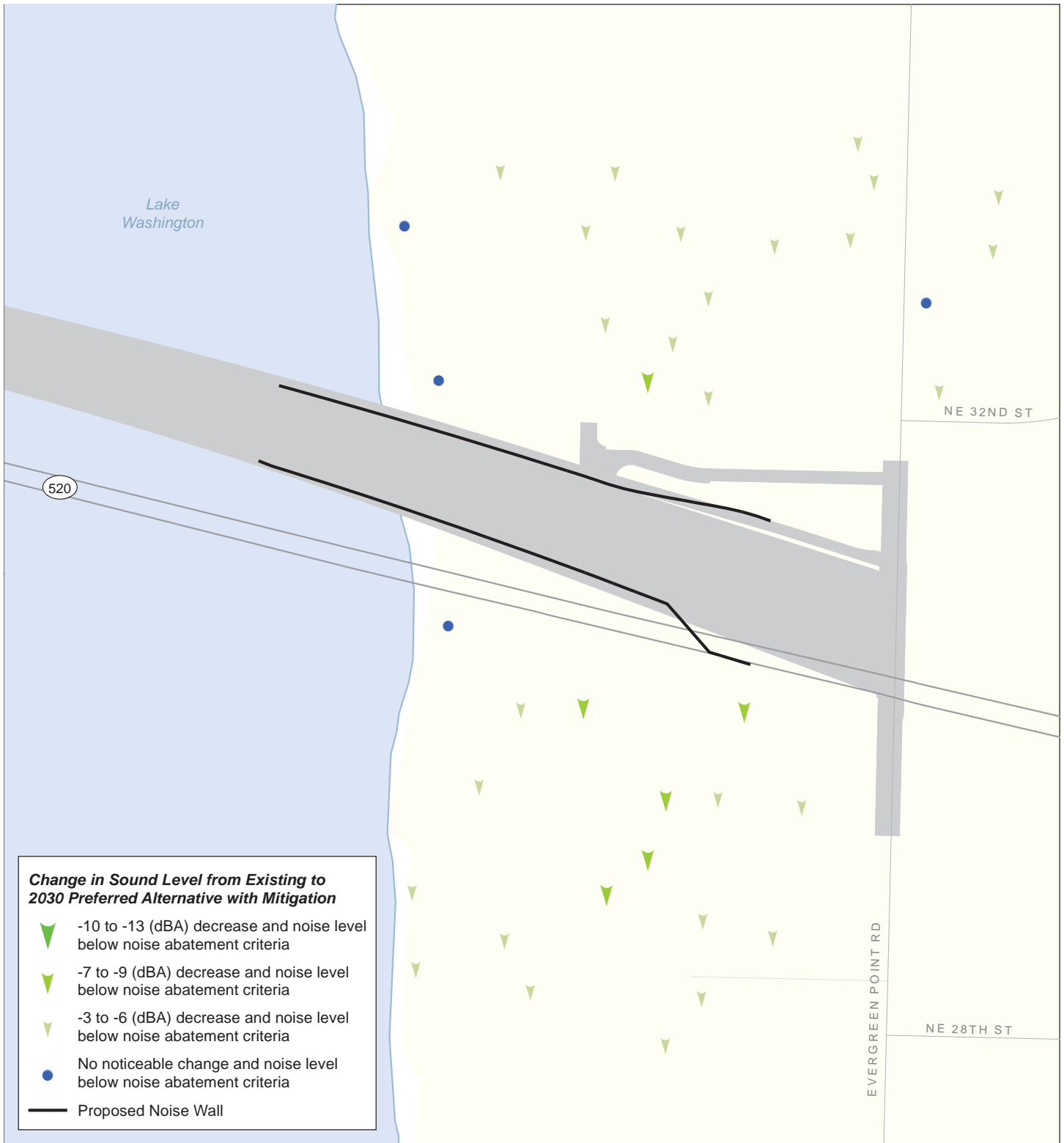

Source: King County (2008) GIS Data (Streets), King County (2007) GIS Data (Water Bodies). Horizontal datum for all layers is NAD83(91); vertical datum for layers is NAVD88.

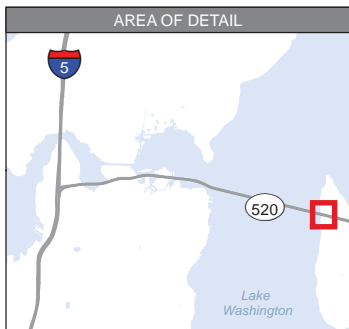

Exhibit 39. Sound Level Changes in the Medina Area with Noise Abatement

I-5 to Medina: Bridge Replacement and HOV Project

Exhibit 40 shows the locations and modeled heights of the recommended noise walls in the Medina area along SR 520, east of Lake Washington. The recommended noise walls in Medina were evaluated using the WSDOT feasibility and reasonableness criteria. The noise-reducing benefits of the Evergreen Point Road lid and the 4-foot tall concrete traffic barriers with noise-absorptive materials are included in the calculated noise levels listed under the “Preferred Alternative Noise Levels without Noise Wall” column shown in Exhibit 41. The noise-reduction amounts listed in Exhibit 41 under the “Noise Reduction” column represent the noise-level reductions expected from the noise wall only. This approach focuses on the effectiveness of each noise wall in reducing traffic noise levels and compares this information directly to the WSDOT cost criteria.

Exhibit 42 summarizes the cost analysis conducted for the noise walls with the Preferred Alternative. Thirty-three residences would benefit from construction of the recommended noise walls. The northern wall would be approximately 860 feet long and 10 to 20 feet tall. The total estimated cost would be \$580,031 at \$53.40 per square foot. Using the allowable cost for noise mitigation from the WSDOT Manual (2008), the available capital for noise mitigation is \$649,000, or \$68,969 more than the estimated cost of the wall. Therefore, the noise wall is considered cost effective and recommended for construction.

If during final design, it is determined that reasonable noise abatement can be achieved by a less costly means, the noise abatement measure might be modified. Any modification to noise abatement measures will receive approval from FHWA and the WSDOT Air Quality, Noise, and Energy Program. Conversely, if design changes create additional noise effects with the final design, the SR 520 project team will provide noise abatement that is consistent with the WSDOT Manual (2008).



Note:
 Wall representation is not to scale. The vertical scale shown is exaggerated to show the height differences better.
 Dotted lines show where the walls are.

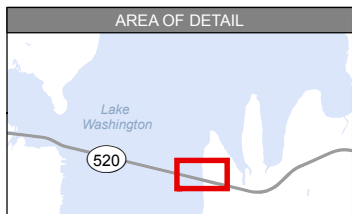
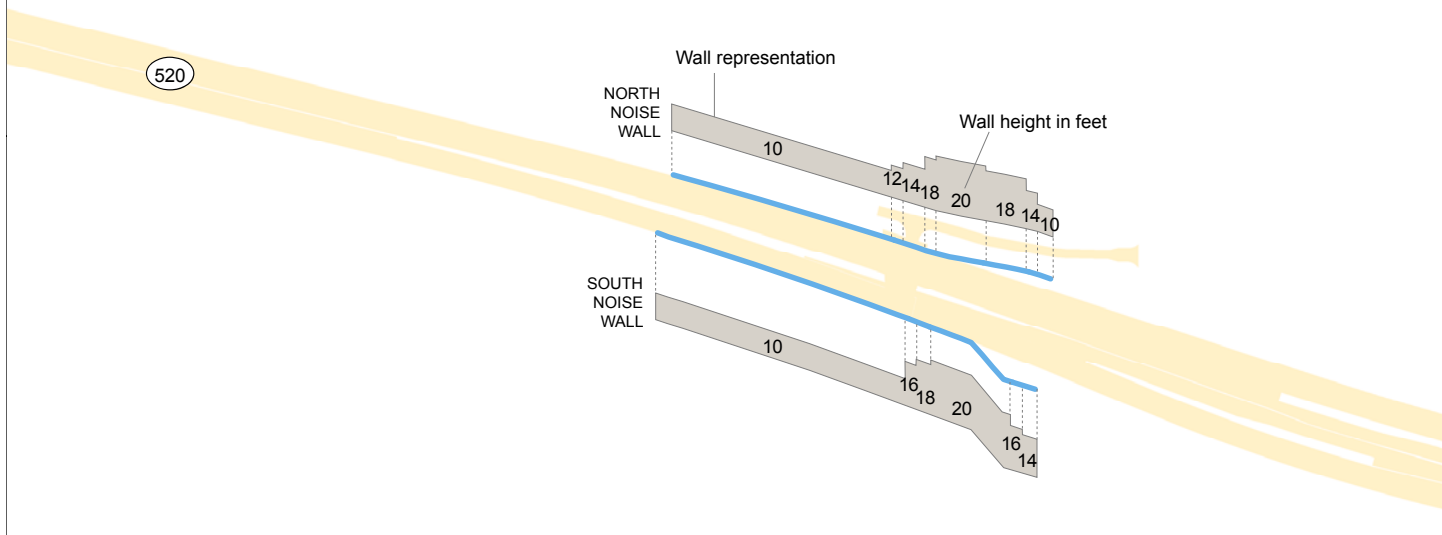

— Proposed Noise Wall
 — Pavement

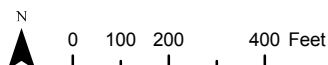

Source: King County (2006) aerial photo. Horizontal datum for all layers is NAD83(91); vertical datum for layers is NAVD88.



Exhibit 40. Noise Wall Locations and Heights for the Preferred Alternative in the Eastside Transition Area

SR 520, I-5 to Medina: Bridge Replacement and HOV Project

Exhibit 41. Noise Wall Performance Summary for Preferred Alternative (Medina North and South)

Receiver Number	Preferred Alternative Noise Levels without Noise Wall ^{a,b}	Preferred Alternative Noise Levels with Noise Wall ^{a,b}	Noise Reduction ^a	Benefited Homes ^d	Capital Available for Noise Abatement ^c
Medina North of SR 520					
PN(LPA)-1	58	57	1	0	\$0.00
PN(LPA)-2	70	62	8	1	\$51,900.00
PN(LPA)-3	70	65	5	1	\$51,900.00
PN(LPA)-4	61	58	3	1	\$37,380.00
PN(LPA)-5	65	61	4	1	\$37,380.00
PN(LPA)-6	64	60	4	1	\$37,380.00
PN(LPA)-7	61	60	1	0	\$0.00
PN(LPA)-8	64	60	4	1	\$37,380.00
PN(LPA)-9	62	59	3	1	\$37,380.00
PN(LPA)-10	67	62	5	1	\$41,110.00
PN(LPA)-11	68	62	6	1	\$44,640.00
PN(LPA)-12	69	64	5	1	\$48,270.00
PN(LPA)-13	62	58	4	1	\$37,380.00
PN(LPA)-14	64	60	4	1	\$37,380.00
PN(LPA)-15	61	57	4	1	\$37,380.00
PN(LPA)-16	53	48	5	1	\$37,380.00
PN(LPA)-17	61	56	5	1	\$37,380.00
PN(LPA)-18	58	56	2	0	\$0.00
PN(LPA)-19	54	50	4	1	\$37,380.00
<i>Total Available for Noise Abatement</i>					<i>\$649,000.00</i>
Medina South of SR 520					
PS(LPA)-1	59	57	2	0	\$0.00
PS(LPA)-2	61	56	5	1	\$37,380.00
PS(LPA)-3	67	59	8	1	\$41,110.00
PS(LPA)-4	68	61	7	1	\$44,640.00
PS(LPA)-5	59	55	4	1	\$37,380.00



Exhibit 41. Noise Wall Performance Summary for Preferred Alternative (Medina North and South)

Receiver Number	Preferred Alternative Noise Levels without Noise Wall ^{a,b}	Preferred Alternative Noise Levels with Noise Wall ^{a,b}	Noise Reduction ^a	Benefited Homes ^d	Capital Available for Noise Abatement ^c
PS(LPA)-6	64	57	7	1	\$37,380.00
PS(LPA)-7	63	57	6	1	\$37,380.00
PS(LPA)-8	62	58	4	1	\$37,380.00
PS(LPA)-9	63	56	7	1	\$37,380.00
PS(LPA)-10	57	54	3	1	\$37,380.00
PS(LPA)-11	59	54	5	1	\$37,380.00
PS(LPA)-12	62	55	7	1	\$37,380.00
PS(LPA)-13	62	56	6	1	\$37,380.00
PS(LPA)-14	62	57	5	1	\$37,380.00
PS(LPA)-15	56	53	3	1	\$37,380.00
PS(LPA)-16	60	54	6	1	\$37,380.00
PS(LPA)-17	60	55	5	1	\$37,380.00
PS(LPA)-18	60	54	6	1	\$37,380.00
<i>Total Available for Noise Abatement</i>					<i>\$646,450.00</i>

^a All noise levels in the exhibit are stated as L_{eq} in dBA.

^b Bold numbers throughout the exhibit indicate noise levels that approach within 1 dBA or exceed the NAC of 67 dBA L_{eq} .

^c Available noise abatement capital from WSDOT criteria for cost evaluation found in the Environmental Procedures Manual, Highway Traffic Noise Analysis and Abatement, Section 446, October 2008.

^d A benefited home is any unit that would receive at 3-dBA insertion loss from the proposed noise abatement measure regardless of whether that unit would have noise levels exceeding the WSDOT NAC with the project.



Exhibit 42. Details and Cost Analysis for Preferred Alternative Noise Walls (Medina North and South)

Noise Wall Description	Heights Along Wall (ft) ^a			Length (ft) ^b	Wall Area (sq ft) ^c	Cost ^d	Available Capital ^e	Residual Capital ^f
	Min	Avg	Max					
Medina North <i>East end of Evergreen Point Bridge to Evergreen Point Road</i>	10	12.6	20	860	10,862	\$580,031	649,000	+ \$68,969
Medina South <i>East end of Evergreen Point Bridge to Evergreen Point Road</i>	10	13.1	20	864	11,369	\$607,105	\$646,450	+ \$39,345

^a Minimum, average, and maximum noise wall heights in feet.

^b Length of recommended noise walls in feet.

^c Total noise wall surface area in square feet.

^d Cost of noise wall based on \$53.40 per square-foot from WSDOT criteria for cost evaluation found in the Environmental Procedures Manual, Highway Traffic Noise Analysis and Abatement, Section 446, October 2008. The cost has been rounded to the nearest whole dollar.

^e Available noise abatement capital from WSDOT criteria for cost evaluation.

^f Residual noise abatement capital: a positive value is within the allowable capital based on WSDOT criteria; a negative value exceeds the criteria.

avg = average

max = maximum

min = minimum

What construction noise abatement and vibration mitigation is normally considered?

Several construction noise and vibration abatement methods (including operational methods, equipment choice, or acoustical treatments) could be implemented to limit the effects of construction noise. The methods used might vary in the SR 520, I-5 to Medina project corridor, depending on construction criteria. The following sections contain some of the more common construction noise abatement and vibration mitigation methods.

Construction Noise Abatement

WSDOT could use various means to abate construction noise, including:

- Limiting operation of construction equipment within 500 feet of any occupied dwelling unit in evening or nighttime hours or on Sundays or legal holidays, when noise and vibration would have the most severe effect.
- Requiring mufflers on all engine-powered equipment to be installed according to the manufacturer's specifications.



- Requiring that all equipment comply with U.S. Environmental Protection Agency equipment noise standards.
- Limiting activities that produce the highest noise levels (such as hauling, loading spoils, jack hammering, and using other demolition equipment) to daytime hours.
- Keeping a construction log for each of the construction staging areas. The log could contain general construction information such as the time an activity occurred, the type of equipment used, and any other information that might help with potential noise effects.
- Establishing a complaint hotline to investigate noise complaints and compare them to the construction logs.
- Developing a construction monitoring and complaint program to help ensure that all equipment meets state, local, and any manufacturer's specifications for noise emissions. Equipment not meeting the standards could be removed from service until proper repairs are made and the equipment is re-tested for compliance.

Recommended noise abatement measures that could be contained in the contract specifications might include:

- Requiring all engine-powered equipment to have mufflers installed according to the manufacturer's specifications.
- Requiring all equipment to comply with pertinent U.S. Environmental Protection Agency equipment noise standards.
- Minimizing noise by regular inspection and replacement of defective mufflers and parts that do not meet the manufacturers' specifications.
- Installing temporary or portable acoustic barriers around stationary construction noise sources and along the sides of the temporary bridge structures, where feasible.
- Where possible, scheduling construction of the residential noise barriers early in the project.
- Locating stationary construction equipment as far from nearby noise-sensitive properties as possible.
- Shutting off idling equipment.
- Rescheduling construction operations to avoid periods of noise annoyance identified in complaints.
- Notifying nearby residents whenever extremely noisy work would be occurring.
- Using broadband backup alarms, as required, for any night work in the Seattle portions of the project. In areas outside Seattle, restrict the use of backup beepers during evening and nighttime



hours and use spotters. In all areas, Occupational Safety and Health Administration will require backup warning devices and spotters for haul vehicles.

- Following the recommendations set forth in the Ecosystems Discipline Report (WSDOT 2009c) regarding protection of aquatic habitat from the effects of pile-driving.

Construction Vibration Mitigation

WSDOT could require vibration monitoring of all activities that might produce vibration levels at or above 0.5 inch per second whenever structures are located near the construction activity. This would include pile-driving, vibratory sheet installation, soil compacting, and other construction activities that had the potential to cause high levels of vibration. There is virtually no effective method to reduce vibration effects from construction. However, by restricting and monitoring vibration-producing activities, vibration effects from construction can be kept to a minimum.

What negative effects would remain after noise abatement?

Overall, with the Preferred Alternative with noise reducing design measures and noise abatement measures, 143 residences or residential equivalents would continue to have noise levels that meet or exceed the NAC. With SDEIS Options A, K, and L, the residual noise effects after noise abatement totaled 94, 123, and 119 residences, respectively. With the No Build Alternative, there would be 287 traffic noise effects within the project area. Currently, 270 residences have noise levels approaching or exceeding the NAC.

With the project's noise-reducing design elements, there would be no negative effects remaining in Laurelhurst or Madison Park. In addition, with the recommended noise abatement measures in Medina, no negative effects would remain in Medina under the Preferred Alternative.

Within the Portage Bay/Roanoke neighborhood, there would be 22 affected residences with the Preferred Alternative, which is less than the 24 predicted under the No Build Alternative. Within the North Capitol Hill neighborhood, 44 residences would have noise levels approaching or exceeding the NAC with the Preferred Alternative compared to 101 under the No Build Alternative.

Compared to the No Build Alternative, the numbers of affected residences and residential equivalents within the Montlake neighborhoods north and south of SR 520 reduce from 42 to 28 and 67 to 39, respectively. Within the University of Washington, the number of affected residential equivalents remains the same as the No Build Alternative. Within the Arboretum, the number of residential equivalents that would have noise levels approaching or exceeding the NAC would be five with the Preferred Alternative compared to 22 under the No Build Alternative. Overall, the number of affected residences under the Preferred Alternative without the recommended noise walls or the 4-foot concrete traffic barrier would be significantly lower than the number under the No Build Alternative or any of the SDEIS options without noise abatement. However, the number of affected residences under the Preferred Alternative with the traffic barriers and noise walls is



slightly higher than any of the SDEIS options with noise abatement. This is primarily because the project design elements reduce noise to levels where other noise abatement, such as noise walls, is no longer feasible and reasonable. Other design elements, such as absorptive treatment on traffic barriers, lid portals, and bridge joints may further reduce noise levels below the values reported in this analysis. By reducing noise levels, the design refinements of the Preferred Alternative reduce the number of recommended noise walls compared to those recommended under the SDEIS options. As previously indicated, this reduction addresses community concerns regarding the aesthetic effects of noise walls.

References

The following list of references is in addition to those listed in the 2009 Noise Discipline Report.

Beranek, L.L., ed. 1988. *Noise and Vibration Control*. Revised edition. Institute of Noise Control Engineering. June 1988.

FHWA. 2005. INFORMATION: *Highway Traffic Noise - Guidance on Quiet Pavement Pilot Programs and Tire/Pavement Noise Research*. FHWA, US DOT January 2005.

WSDOT. 2008. *Environmental Procedures Manual, Highway Traffic Noise Analysis and Abatement*. Section 446. October 2008.

WSDOT. 2009a. *Noise Discipline Report*. SR 520: I-5 to Medina Bridge Replacement and HOV Project. Supplemental Draft Environmental Impact Statement and Section 4(f)/6(f) Evaluation. SR 520 Bridge Replacement and HOV Program. WSDOT, Olympia, WA. December 2009.

WSDOT. 2009b. *Land Use, Economics, and Relocations Discipline Report*. I-5 to Medina: Bridge Replacement and HOV Project, SR 520 Bridge Replacement and HOV Program. WSDOT, Olympia, WA. December 2009.

WSDOT. 2009c. *Ecosystems Discipline Report*. I-5 to Medina: Bridge Replacement and HOV Project, SR 520 Bridge Replacement and HOV Program. WSDOT, Olympia, WA. December 2009.

WSDOT. 2010. *SR 520, I-5 to Medina: Bridge Replacement and HOV Project Supplemental Draft Environmental Impact Statement and Section 4(f)/6(f) Evaluation*. SR 520 Bridge Replacement and HOV Program. WSDOT, Olympia, WA. January 2010.

WSDOT. 2011a. *Description of Alternatives Discipline Report Addendum*. SR 520, I-5 to Medina: Bridge Replacement and HOV Project. WSDOT, Olympia, WA.

WSDOT. 2011b. *Construction Techniques and Activities Discipline Report Addendum and Errata*. SR 520, I-5 to Medina: Bridge Replacement and HOV Project. WSDOT, Olympia, WA.

WSDOT. 2011c. *Final Transportation Discipline Report*. SR 520, I-5 to Medina: Bridge Replacement and HOV Project. WSDOT, Olympia, WA.



USDOT. 1980. "Structure Response and Damage Produced by Ground Vibration from Surface Mine Blasting." United States Bureau of Mines Report of Investigations R.I. 8507.

USDOT. 1997. *FHWA Highway Construction Noise, Measurement, Prediction and Mitigation.*

USDOT.2008. *FHWA Roadway Construction Noise Model. Version 1.1.*



Attachment 1

Noise Discipline Report Errata

Attachment 1

Noise Discipline Report Errata

The following table corrects errors in and provides clarifications to the Noise Discipline Report (WSDOT 2009a). Information contained in this table does not change the results or conclusions of any analyses in the 2009 discipline report.

Page	Current Text	Corrected Text/Clarification
3	<ul style="list-style-type: none"> Usual and accustomed fishing areas of tribal nations that have historically used the area’s aquatic resources and have treaty rights 	<ul style="list-style-type: none"> Usual and accustomed fishing areas <u>of the Muckleshoot Tribe, which has</u> tribal nations that have historically used the area’s aquatic resources and have <u>treaty rights for their protection and use</u>



Attachment 2

Residential-Equivalent Calculations for the Project Study Area

Exhibit 2A. Residential-Equivalent Calculations based on WSDOT D22-22 (see table footnote)

Receiver	Area Represented	Summer Users	Hours/Day	Months/Year	Winter Users	Hours/Day	Months/Year	Residential Equivalents
Montlake North								
MN-1	NOAA NWFSC – outside use area	10	12	6	5	8	6	3.3
MN-2	NOAA NWFSC – outside use area	10	12	6	5	8	6	3.3
MN-11	NOAA NWFSC – outside use area	10	12	6	5	8	6	3.3
MN-12	Boat docks – Portage Bay	10	12	6	5	8	6	3.3
MN-22	Park	10	12	6	5	8	6	3.3
MN-29	Park	10	12	6	5	8	6	3.3
MN-30	Park	10	12	6	5	8	6	3.3
Montlake South								
MS-21	School – track/field	30	12	6	10	8	6	9.2
MS-22	School – track/field	30	12	6	10	8	6	9.2
MS-23	School – building	30	12	6	10	8	6	9.2
Arboretum								
AB-1	Park	15	12	6	10	8	6	5.4
AB-2	Park	15	12	6	10	8	6	5.4
AB-3	Park	15	12	6	10	8	6	5.4
AB-4 through AB-13 are model locations used only to determine areas within the Arboretum where the NAC is approached or exceeded—no residential equivalents are represented by these receivers.								
AB-14	Park	15	12	6	10	8	6	5.4
AB-15	Park	15	12	6	10	8	6	5.4
AB-16	Park	15	12	6	10	8	6	5.4
AB-17	Park	15	12	6	10	8	6	5.4
AB-18	Park	15	12	6	10	8	6	5.4
AB-19	Park	15	12	6	10	8	6	5.4
AB-20	Park	15	12	6	10	8	6	5.4
University of Washington^a								
UW-1	Open Space	10	–	–	10	5	9	2.2
UW-2	Open Space	10	–	–	10	5	9	2.2



Exhibit 2A. Residential-Equivalent Calculations based on WSDOT D22-22 (see table footnote)

Receiver	Area Represented	Summer Users	Hours/Day	Months/Year	Winter Users	Hours/Day	Months/Year	Residential Equivalents
UW-3	Open Space	10	–	–	10	5	9	2.2
UW-4	Open Space	10	–	–	10	5	9	2.2
UW-5	Stadium area	50	–	–	10	5	9	11.2
UW-6	Stadium area	15	–	–	10	5	9	3.3
UW-7	Stadium area	25	–	–	10	5	9	5.6
UW-8	Stadium area	25	–	–	10	5	9	5.6
UW-9	Stadium area	100	–	–	10	5	9	22.3
UW-10	Stadium area	25	–	–	10	5	9	5.6
UW-11	Gym entrance	10	–	–	10	5	9	2.2
UW-12	Gym entrance	10	–	–	10	5	9	2.2
UW-13	Near Hospital	50	–	–	6	3	12	5.4
UW-14	Near Hospital	25	–	–	6	3	12	2.7
UW-15	Open space	10	–	–	10	5	9	2.2
UW-16	Classrooms	25	–	–	10	5	9	5.6
Madison Park								
MP-10	Park	50	12	6	25	8	6	16.7
MP-11	Park	50	12	6	25	8	6	16.7

^a Use D22-22 Usage factors for schools (0.22) and hospitals (1.0). (WSDOT. October 2008. *Environmental Procedures Manual, Highway Traffic Noise Analysis and Abatement*. Section 446)

Note: Less than 12 months per year are typically assumed for parks and trails; however, because of the high density of residential structures around these areas, and conferences with local residences, the analysts assumed a full year of use.



Attachment 3

Noise Modeling Locations, Levels Dnd Changes in Project Study Area

Attachment 3A Noise Modeling Locations, Levels, and Changes for the Harvard Roanoke Neighborhood

Receiver Number	Units Represented	WSDOT NAC	Existing	No Build Alternative	Preferred Alternative Without Noise Walls (includes 4 Ft. Traffic Barrier)	Preferred Alternative with Noise Walls	Difference between Preferred Alternative with Noise Walls and Existing	Difference between Preferred Alternative with Noise Walls and No Build
HR-1	4	66	77	78	78	78	1	0
HR-2	4	66	75	76	75	75	0	-1
HR-3	2	66	72	73	71	71	-1	-2
HR-4	3	66	66	66	66	66	0	0
HR-5	3	66	67	67	70	70	3	3
HR-6	1	66	75	75	- ^a	- ^a	- ^a	- ^a
HR-7	2	66	64	65	60	60	-4	-5
HR-8	1	66	62	64	59	59	-3	-5
HR-9	1	66	68	67	58	58	-10	-9
HR-10	4	66	63	63	61	61	-2	-2
HR-11	4	66	56	56	61	61	5	5
HR-12	4	66	63	64	64	64	1	0
HR-13	5	66	64	65	64	64	0	-1
HR-14	3	66	67	67	67	67	0	0
HR-15	3	66	74	73	74	74	0	1
HR-16	1	66	64	65	64	64	0	-1
HR-17	3	66	63	64	63	63	0	-1
HR-18	4	66	61	61	62	62	1	1
HR-19	4	66	61	61	59	59	-2	-2
HR-20	4	66	60	60	58	58	-2	-2
HR-21	3	66	58	57	58	58	0	1
HR-22	5	66	63	63	57	57	-6	-6
HR-23	6	66	61	61	58	58	-3	-3
BH-1	3	66	63	63	57	57	-6	-6
BH-2	3	66	64	64	58	58	-6	-6
BH-3	3	66	62	62	57	57	-5	-5

Notes: All noise levels in the exhibit are Leq in dBA.

Noise levels in red meet the WSDOT NAC.

^aThis receiver would be displaced by the Preferred Alternative

Attachment 3B Noise Modeling Locations, Levels, and Changes for the Capitol Hill Neighborhood

Receiver Number	Units Represented	WSDOT NAC	Existing	No Build Alternative	Preferred Alternative Without Noise Walls (includes 4 Ft. Traffic Barrier)	Preferred Alternative with Noise Walls	Difference between Preferred Alternative with Noise Walls and Existing	Difference between Preferred Alternative with Noise Walls and No Build
CH-1	3	66	73	73	72	72	-1	-1
CH-2	2	66	71	71	73	73	2	2
CH-3	4	66	66	66	62	62	-4	-4
CH-4	4	66	64	65	63	63	-1	-2
CH-5	2	66	65	66	65	65	0	-1
CH-6 Upper	9	66	72	72	66	66	-6	-6
CH-6 Lower	9	66	72	72	62	62	-10	-10
CH-7	4	66	68	68	59	59	-9	-9
CH-8	24	66	67	66	60	60	-7	-6
CH-9	8	66	67	66	60	60	-7	-6
CH-10	1	66	64	64	63	63	-1	-1
CH-11	3	66	63	63	62	62	-1	-1
CH-12	8	66	65	65	65	65	0	0
CH-13	6	66	69	69	69	69	0	0
CH-14	5	66	65	65	64	64	-1	-1
CH-15	6	66	66	66	65	65	-1	-1
CH-16	20	66	66	67	67	67	1	0
CH-17	6	66	63	63	63	63	0	0
CH-18	4	66	62	63	61	61	-1	-2
CH-19	2	66	63	63	61	61	-2	-2
CH-20	4	66	63	63	60	60	-3	-3
CH-21	14	66	64	64	58	58	-6	-6
CH-22	16	66	64	64	58	58	-6	-6
CH-23	8	66	64	64	58	58	-6	-6
CH-24	14	66	62	62	58	58	-4	-4
CH-25	6	66	63	62	60	60	-3	-2
CH-26	7	66	62	62	60	60	-2	-2
CH-27	6	66	62	62	60	60	-2	-2

Attachment 3B Noise Modeling Locations, Levels, and Changes for the Capitol Hill Neighborhood

Receiver Number	Units Represented	WSDOT NAC	Existing	No Build Alternative	Preferred Alternative Without Noise Walls (includes 4 Ft. Traffic Barrier)	Preferred Alternative with Noise Walls	Difference between Preferred Alternative with Noise Walls and Existing	Difference between Preferred Alternative with Noise Walls and No Build
CH-28	4	66	69	71	69	69	0	-2
CH-29	3	66	61	61	60	60	-1	-1
CH-30	5	66	61	60	59	59	-2	-1
CH-31	1	66	60	60	58	58	-2	-2
CH-32	1	66	61	61	59	59	-2	-2

Notes: All noise levels in the exhibit are Leq in dBA.
 Noise levels in red meet the WSDOT NAC

Attachment 3C Noise Modeling Locations, Levels, and Changes for the Montlake North Neighborhood

Receiver Number	Units Represented	WSDOT NAC	Existing	No Build Alternative	Preferred Alternative Without Noise Walls (includes 4 Ft. Traffic Barrier)	Preferred Alternative with Noise Walls	Difference between Preferred Alternative with Noise Walls and Existing	Difference between Preferred Alternative with Noise Walls and No Build
MN-1	3.3 ^c	66	69	67	62	62	-7	-5
MN-2	3.3 ^c	66	66	67	64	64	-2	-3
MN-3	0	N/A	75	73	- ^a	- ^a	- ^a	- ^a
MN-4	2	66	67	67	61	61	-6	-6
MN-5	3	66	67	67	62	62	-5	-5
MN-6	3	66	66	68	67	67	1	-1
MN-7	2	66	69	74	73	73	4	-1
MN-8	3	66	68	71	72	72	4	1
MN-9	3	66	64	66	65	65	1	-1
MN-10	4	66	64	64	62	62	-2	-2
MN-11	3.3 ^c	66	66	65	61	61	-5	-4
MN-12	3.3 ^c	66	65	64	60	60	-5	-4
MN-13	4	66	64	63	60	60	-4	-3
MN-14	3	66	64	63	61	61	-3	-2
MN-15	4	66	64	63	62	62	-2	-1
MN-16	4	66	63	64	64	64	1	0
MN-17	4	66	68	70	73	73	5	3
MN-18	3	66	72	73	72	72	0	-1
MN-19	5	66	62	65	64	64	2	-1
MN-20	3	66	60	64	62	62	2	-2
MN-21	3	66	61	63	61	61	0	-2
MN-22	3.3 ^c	66	63	63	60	60	-3	-3
MN-23	4	66	68	70	72	72	4	2
MN-24	3	66	62	62	59	59	-3	-3
MN-25	2	66	63	66	65	65	2	-1
MN-26	2	66	72	68	71	71	-1	3
MN-27	3	66	65	65	66	66	1	1
MN-28	6	66	60	61	62	62	2	1
MN-29	3.3 ^c	66	65	64	62	62	-3	-2

Attachment 3C Noise Modeling Locations, Levels, and Changes for the Montlake North Neighborhood

Receiver Number	Units Represented	WSDOT NAC	Existing	No Build Alternative	Preferred Alternative Without Noise Walls (includes 4 Ft. Traffic Barrier)	Preferred Alternative with Noise Walls	Difference between Preferred Alternative with Noise Walls and Existing	Difference between Preferred Alternative with Noise Walls and No Build
MN-30	3.3 ^c	66	60	60	60	60	0	0
MN-31	4	66	59	60	61	61	2	1
MN-32	2	66	62	64	65	65	3	1
MN-33	1	66	64	66	67	67	3	1
MN-34	1	66	66	72	69	69	3	-3
MN-35	2	66	63	68	67	67	4	-1

Notes: All noise levels in the exhibit are Leq in dBA.

Noise levels in red meet WSDOT NAC.

^aThis receiver would be displaced by the Preferred Alternative

N/A = MN-3 is near the existing SR 520 alignment and was used only to aid in model verification. Because it is not a location representing a noise-sensitive property, the NAC does not

Attachment 3D Noise Modeling Locations, Levels and Changes for the Montlake South Neighborhood

Receiver Number	Units Represented	WSDOT NAC	Existing	No Build Alternative	Preferred Alternative Without Noise Walls (includes 4 Ft. Traffic Barrier)	Preferred Alternative with Noise Walls	Difference between Preferred Alternative with Noise Walls and Existing	Difference between Preferred Alternative with Noise Walls and No Build
MS-1	4	66	74	75	75	75	1	0
MS-2	4	66	74	73	70	70	-4	-3
MS-3	6	66	74	72	67	67	-7	-5
MS-4	3	66	72	70	68	68	-4	-2
MS-5	5	66	70	68	67	67	-3	-1
MS-6	4	66	59	58	59	59	0	1
MS-7	4	66	59	58	59	59	0	1
MS-8	3	66	61	61	62	62	1	1
MS-9	2	66	62	64	65	65	3	1
MS-10	4	66	67	70	70	70	3	0
MS-11	2	66	60	62	62	62	2	0
MS-12	4	66	56	57	58	58	2	1
MS-13	4	66	58	56	58	58	0	2
MS-14	4	66	60	59	59	59	-1	0
MS-15	6	66	56	56	58	58	2	2
MS-16	4	66	62	62	63	63	1	1
MS-17	2	66	73	72	72	72	-1	0
MS-18	4	66	65	69	70	70	5	1
MS-19	4	66	66	67	66	66	0	-1
MS-20	3	66	66	66	66	66	0	0
MS-21	9.2 ^a	66	70	69	62	62	-8	-7
MS-22	9.2 ^a	66	69	68	60	60	-9	-8
MS-23	9.2 ^a	66	66	66	59	59	-7	-7
MS-24	2	66	63	63	58	58	-5	-5
MS-25	2	66	63	63	58	58	-5	-5
MS-26	4	66	63	56	56	56	-7	0
MS-27	3	66	65	65	62	62	-3	-3
MS-28	4	66	64	65	63	63	-1	-2
MS-29	4	66	63	63	63	63	0	0
MS-30	4	66	64	65	65	65	1	0

Attachment 3D Noise Modeling Locations, Levels and Changes for the Montlake South Neighborhood

Receiver Number	Units Represented	WSDOT NAC	Existing	No Build Alternative	Preferred Alternative Without Noise Walls (includes 4 Ft. Traffic Barrier)	Preferred Alternative with Noise Walls	Difference between Preferred Alternative with Noise Walls and Existing	Difference between Preferred Alternative with Noise Walls and No Build
MS-31	6	66	58	56	58	58	0	2
MS-32	4	66	61	59	60	60	-1	1
MS-33	5	66	64	62	63	63	-1	1

Notes: All noise levels in the exhibit are Leq in dBA.

Noise levels in red meet WSDOT NAC.

^aIncludes residential equivalents for the outside activity areas represented by this receiver.

Attachment 3E Noise Modeling Locations, Levels and Changes for the University of Washington Area

Receiver Number	Units Represented	WSDOT NAC	Existing	No Build Alternative	Preferred Alternative Without Noise Walls (includes 4 Ft. Traffic Barrier)	Preferred Alternative with Noise Walls	Difference between Preferred Alternative with Noise Walls and Existing	Difference between Preferred Alternative with Noise Walls and No Build
UW-1	2.2 ^a	66	65	68	69	69	4	1
UW-2	2.2 ^a	66	58	61	62	62	4	1
UW-3	2.2 ^a	— ^d	55	57	58	58	3	1
UW-4	2.2 ^a	66	54	56	56	56	2	0
UW-5	11.2 ^a	66	54	56	57	57	3	1
UW-6	3.3 ^a	66	58	60	60	60	2	0
UW-7	5.6 ^a	66	62	64	63	63	1	-1
UW-8	5.6 ^a	66	52	55	55	55	3	0
UW-9	22.3 ^a	66	53	56	56	56	3	0
UW-10	5.6 ^a	66	62	65	65	65	3	0
UW-11	2.2 ^a	66	66	68	68	68	2	0
UW-12	2.2 ^a	66	64	65	65	65	1	0
UW-13	5.4 ^a	66	59	62	62	62	3	0
UW-14	2.7 ^a	66	61	65	65	65	4	0
UW-15	2.2 ^a	66	64	65	65	65	1	0
UW-16	5.6 ^a	66	62	62	63	63	1	1

Notes: All noise levels in the exhibit are Leq in dBA.

Noise levels in red meet the WSDOT NAC.

^aIncludes residential equivalents for the outside activity areas represented by this receiver.

Attachment 3F Noise Modeling Locations, Levels and Changes for the Arboretum Area

Receiver Number	Units Represented	WSDOT NAC	Existing	No Build Alternative	Preferred Alternative Without Noise Walls (includes 4 Ft. Traffic Barrier)	Preferred Alternative with Noise Walls	Difference between Preferred Alternative with Noise Walls and Existing	Difference between Preferred Alternative with Noise Walls and No Build
AB-1	5.4 ^b	66	66	65	61	61	-5	-4
AB-2	5.4 ^b	66	67	66	62	62	-5	-4
AB-3	5.4 ^b	66	68	68	62	62	-6	-6
AB-4	0 ^c	66	80	82	— ^a	— ^a	— ^a	— ^a
AB-5	0 ^c	66	76	79	— ^a	— ^a	— ^a	— ^a
AB-6	0 ^c	66	72	74	61	61	-11	-13
AB-7	0 ^c	66	70	72	62	62	-8	-10
AB-8	0 ^c	66	69	71	62	62	-7	-9
AB-9	0 ^c	66	68	70	63	63	-5	-7
AB-10	0 ^c	66	67	69	63	63	-4	-6
AB-11	0 ^c	66	67	68	63	63	-4	-5
AB-12	0 ^c	66	66	67	63	63	-3	-4
AB-13	0 ^c	66	65	67	63	63	-2	-4
AB-14	5.4 ^b	66	63	64	62	62	-1	-2
AB-15	5.4 ^b	66	71	72	66	66	-5	-6
AB-16	5.4 ^b	66	65	66	64	64	-1	-2
AB-17	5.4 ^b	66	60	61	60	60	0	-1
AB-18	5.4 ^b	66	56	56	55	55	-1	-1
AB-19	5.4 ^b	66	64	62	58	58	-6	-4
AB-20	5.4 ^b	66	63	62	62	62	-1	0

Notes: All noise levels in the exhibit are Leq in dBA.

Noise levels in red meet the WSDOT NAC.

^aThis receiver would be displaced by the Preferred Alternative

^bIncludes residential equivalents for the outside activity areas represented by this receiver.

^cThis receiver was used only to validate the noise model and to determine the distance from SR520 to where the NAC of 67 dBA Leq would be approached or exceeded within the Arboretum.

Attachment 3G Noise Modeling Locations, Levels and Changes for the Madison Park Neighborhood

Receiver Number	Units Represented	WSDOT NAC	Existing	No Build Alternative	Preferred Alternative Without Noise Walls (includes 4 Ft. Traffic Barrier)	Preferred Alternative with Noise Walls	Difference between Preferred Alternative with Noise Walls and Existing	Difference between Preferred Alternative with Noise Walls and No Build
MP-1	3	66	66	66	62	62	-4	-4
MP-2	2	66	67	67	62	62	-5	-5
MP-3	2	66	68	68	62	62	-6	-6
MP-4	3	66	69	69	63	63	-6	-6
MP-5	3	66	66	66	62	62	-4	-4
MP-6	2	66	63	63	61	61	-2	-2
MP-7	3	66	61	61	59	59	-2	-2
MP-8	3	66	60	60	57	57	-3	-3
MP-9	4	66	61	61	58	58	-3	-3
MP-10	16.7 ^a	66	61	61	59	59	-2	-2
MP-11	16.7 ^a	66	61	61	59	59	-2	-2
MP-12	4	66	59	59	57	57	-2	-2
MP-13	3	66	60	60	59	59	-1	-1
MP-14	4	66	61	61	59	59	-2	-2
MP-15	4	66	61	61	59	59	-2	-2
MP-16	4	66	63	63	61	61	-2	-2
MP-17	3	66	64	64	62	62	-2	-2
MP-18	5	66	65	65	62	62	-3	-3
MP-19	3	66	66	66	64	64	-2	-2
MP-20	3	66	64	64	63	63	-1	-1
MP-21	1	66	60	60	58	58	-2	-2
MP-22	4	66	58	59	56	56	-2	-3
MP-23	3	66	57	56	56	56	-1	0

Notes: All noise levels in the exhibit are Leq in dBA.

Noise levels in red meet the WSDOT NAC.

^aIncludes residential equivalents for the outside activity areas represented by this receiver.

Attachment 3H Noise Modeling Locations, Levels and Changes for the Laurelhurst Neighborhood								
Receiver Number	Units Represented	WSDOT NAC	Existing	No Build Alternative	Preferred Alternative Without Noise Walls (includes 4 Ft. Traffic Barrier)	Preferred Alternative with Noise Walls	Difference between Preferred Alternative with Noise Walls and Existing	Difference between Preferred Alternative with Noise Walls and No Build
LH-1	2	66	61	61	60	60	-1	-1
LH-2	2	66	60	61	59	59	-1	-2
LH-3	2	66	59	60	59	59	0	-1
LH-4	2	66	60	60	59	59	-1	-1
LH-5	2	66	53	56	55	55	2	-1
LH-6	3	66	57	57	56	56	-1	-1
LH-7	2	66	51	56	53	53	2	-3

Notes: All noise levels in the exhibit are Leq in dBA.

Attachment 3I Noise Modeling Locations, Levels and Changes for the Medina Neighborhood

Receiver Number	Units Represented	WSDOT NAC	Existing	No Build Alternative	Preferred Alternative without Noise Walls (includes 4 Ft. Traffic Barrier)	Preferred Alternative with Noise Walls	Difference between Preferred Alternative with Noise Walls and Existing	Difference between Preferred Alternative with Noise Walls and No Build	Noise Reduction from Noise Walls (Difference between Preferred Alternative with Noise Walls and Preferred Alternative with 4 Ft. Traffic Barrier)
PN(LPA)-1	1	66	68	68	58 ^a	57	-11	-11	-1
PN(LPA)-2	1	66	65	66	70	62	-3	-4	-8
PN(LPA)-3	1	66	65	66	70	65	0	-1	-5
PN(LPA)-4	1	66	63	64	61	58	-5	-6	-3
PN(LPA)-5	1	66	60	61	65	61	1	0	-4
PN(LPA)-6	1	66	61	62	64	60	-1	-2	-4
PN(LPA)-7	1	66	65	66	61	60	-5	-6	-1
PN(LPA)-8	1	66	59	60	64	60	1	0	-4
PN(LPA)-9	1	66	61	61	62	59	-2	-2	-3
PN(LPA)-10	1	66	62	63	67	62	0	-1	-5
PN(LPA)-11	1	66	64	64	68	62	-2	-2	-6
PN(LPA)-12	1	66	63	64	69	64	1	0	-5
PN(LPA)-13	1	66	59	60	62	58	-1	-2	-4
PN(LPA)-14	1	66	60	60	64	60	0	0	-4
PN(LPA)-15	1	66	57	58	61	57	0	-1	-4
PN(LPA)-16	1	66	56	57	53	48	-8	-9	-5
PN(LPA)-17	1	66	56	57	61	56	0	-1	-5
PN(LPA)-18	1	66	60	61	58	56	-4	-5	-2
PN(LPA)-19	1	66	58	58	54	50	-8	-8	-4
PS (LPA)-1	1	66	70	70	59	57	-13	-13	-2
PS (LPA)-2	1	66	67	68	61	56	-11	-12	-5
PS (LPA)-3	1	66	69	70	67	59	-10	-11	-8
PS (LPA)-4	1	66	73	74	68	61	-12	-13	-7
PS (LPA)-5	1	66	65	66	59	55	-10	-11	-4
PS (LPA)-6	1	66	66	67	64	57	-9	-10	-7
PS (LPA)-7	1	66	66	67	63	57	-9	-10	-6
PS (LPA)-8	1	66	67	68	62	58	-9	-10	-4

Attachment 3I Noise Modeling Locations, Levels and Changes for the Medina Neighborhood

Receiver Number	Units Represented	WSDOT NAC	Existing	No Build Alternative	Preferred Alternative without Noise Walls (includes 4 Ft. Traffic Barrier)	Preferred Alternative with Noise Walls	Difference between Preferred Alternative with Noise Walls and Existing	Difference between Preferred Alternative with Noise Walls and No Build	Noise Reduction from Noise Walls (Difference between Preferred Alternative with Noise Walls and Preferred Alternative with 4 Ft. Traffic Barrier)
PS (LPA)-9	1	66	64	64	63	56	-8	-8	-7
PS (LPA)-10	1	66	63	64	57	54	-9	-10	-3
PS (LPA)-11	1	66	60	61	59	54	-6	-7	-5
PS (LPA)-12	1	66	62	63	62	55	-7	-8	-7
PS (LPA)-13	1	66	62	63	62	56	-6	-7	-6
PS (LPA)-14	1	66	63	63	62	57	-6	-6	-5
PS (LPA)-15	1	66	61	62	56	53	-8	-9	-3
PS (LPA)-16	1	66	59	60	60	54	-5	-6	-6
PS (LPA)-17	1	66	61	61	60	55	-6	-6	-5
PS (LPA)-18	1	66	59	60	60	54	-5	-6	-6

Notes: All noise levels in the exhibit are Leq in dBA.

a This receiver would be well within the noise shadow zone created by the proposed elevated SR 520 roadway which explains the lower noise levels under the Preferred Alternative compared to the existing and No Build conditions.

Attachment 4

WSDOT Special Noise Barrier Applications Phase II

SPECIAL NOISE BARRIER APPLICATIONS Phase II

WA-RD 378.1

Final Report
March 1995



**Washington State
Department of Transportation**

Washington State Transportation Commission
Planning and Programming Service Center
in cooperation with the U.S. Department of Transportation
Federal Highway Administration

Final Report

SPECIAL NOISE BARRIER APPLICATIONS

Phase II

by

Louis F. Cohn, Ph.D., P.E.
Roswell A. Harris, Ph.D., P.E.

Department of Civil Engineering
University of Louisville
Louisville, KY 40292
(502) 852-6276

Submitted to:

Research Office
Planning and Programming Service Center
Washington State Department of Transportation
and in cooperation with
U.S. Department of Transportation
Federal Highway Administration

March 9, 1995

TABLE OF CONTENTS

<u>Section</u>	<u>Page</u>
Disclaimer	1
Executive Summary	2
Problem Statement	7
Objective	8
Special Noise Barriers	9
Shaped Barrier Tops	9
Absorptive T-top Barriers	10
Y-top Barriers	11
Slanted-top Barriers	13
Absorptive Noise Barriers	14
Single Wall Absorptive Barriers	14
Absorptive Parallel Barriers	15
Special Noise Barrier Feasibility and Impacts	16
Acoustic Feasibility	16
Acoustic Impacts	18
Absorptive T-top Barriers	18
Y-top Barriers	21
Slanted-top Barriers	22
Single-Wall Absorptive Barriers	23
Absorptive Parallel Barriers	23
Aesthetic Feasibility	24
Aesthetic Impacts	28
Economic Feasibility	29
Structural Considerations	30
Absorptive T-top Barriers	32
Y-top Barriers	32
Slanted-top Barriers	32
Absorptive Barriers	33
Maintenance Considerations	33
Economic Impacts	36
Standard Barrier Design	39
STAMINA 2.0 and OPTIMA Modeling	40
Noise Software Library	40
Modeling Procedures	40
Seattle Projects	43
Fourth Avenue SE and Magnolia Road	43
Fourth Avenue	45
Magnolia Road	45
Kent Commons Play Field	46
Spokane Project	47
Spokane Community College Area	48

TABLE OF CONTENTS (Continued)

<u>Section</u>	<u>Page</u>
Modifications to Standard Barrier Design	51
Fourth Avenue	55
Magnolia Road	56
Kent Commons Play Field	57
Spokane Community College Area	57
Conclusions and Recommendations	60
References	62
Appendix A	
Site Maps	
Fourth Avenue	A-1
Magnolia Road	A-2
Kent Commons Play Field	A-3
Spokane Community College	A-4
Appendix B	
Tables I-XVIII	B-1 thru B-21

LIST OF TABLES

<u>TABLE</u>		<u>PAGE</u>
I	OPTIMA RESULTS FOR SLANTED TOP MODELING	B-1
II	SPOKANE COMMUNITY COLLEGE AREA INSERTION LOSS COMPARISON BETWEEN SINGLE BARRIER AND REFLECTIVE AND ABSORPTIVE PARALLEL BARRIERS	B-2
III	FOURTH AVENUE COMPARISON OF NOISE ANALYSIS RESULTS FOR 1975 FHWA VERSUS 1993 WASHINGTON STATE REFERENCE MEAN EMISSION LEVELS	B-4
IV	MAGNOLIA ROAD COMPARISON OF NOISE ANALYSIS RESULTS FOR 1975 FHWA VERSUS 1993 WASHINGTON STATE REFERENCE MEAN EMISSION LEVELS	B-5
V	KENT COMMONS PLAY FIELD COMPARISON OF NOISE ANALYSIS RESULTS FOR 1975 FHWA VERSUS 1993 WASHINGTON STATE REFERENCE MEAN EMISSION LEVELS	B-6
VI	SPOKANE COMMUNITY COLLEGE AREA COMPARISON OF NOISE ANALYSIS RESULTS FOR 1975 FHWA VERSUS 1993 WASHINGTON STATE REFERENCE MEAN EMISSION LEVELS	B-7
VII	FOURTH AVENUE LINE-OF-SIGHT BREAKS	B-9
VIII	FOURTH AVENUE COMPARISON OF NOISE ANALYSIS RESULTS U OF L VERSUS WSDOT	B-10
IX	MAGNOLIA ROAD LINE-OF-SIGHT BREAKS	B-11
X	MAGNOLIA ROAD COMPARISON OF NOISE ANALYSIS RESULTS U OF L VERSUS WSDOT	B-12
XI	KENT COMMONS PLAY FIELD LINE-OF-SIGHT BREAKS	B-13
XII	KENT COMMONS PLAY FIELD COMPARISON OF NOISE ANALYSIS RESULTS U OF L VERSUS WSDOT	B-14
XIII	SPOKANE COMMUNITY COLLEGE AREA LINE-OF-SIGHT BREAKS	B-15

LIST OF TABLES (Continued)

<u>TABLE</u>		<u>PAGE</u>
XIV	SPOKANE COMMUNITY COLLEGE AREA COMPARISON OF NOISE ANALYSIS RESULTS U OF L VERSUS WSDOT	B-16
XV	FOURTH AVENUE COMPARISON OF BARRIER TYPES	B-18
XVI	MAGNOLIA ROAD COMPARISON OF BARRIER TYPES	B-19
XVII	KENT COMMONS PLAY FIELD COMPARISON OF BARRIER TYPES	B-20
XVIII	SPOKANE COMMUNITY COLLEGE AREA COMPARISON OF BARRIER TYPES	B-21

LIST OF FIGURES

<u>FIGURE</u>		<u>PAGE</u>
1	Absorptive T-top Barrier	11
2	Y-top Barrier	12
3	Slanted-top Barrier	13
4	Parallel Barriers	15
5	Line-of-Sight Break	17

DISCLAIMER

The contents of this report reflect the views of the authors, who are responsible for the facts and the accuracy of the data presented herein. The contents do not necessarily reflect the official views or policies of the Washington State Transportation Commission, Department of Transportation, or the Federal Highway Administration. This report does not constitute a standard, specification, or regulation.

EXECUTIVE SUMMARY

This report examines five special noise barrier applications that exist in addition to the conventional vertical reflective barrier. The acoustic, aesthetic, and economic feasibility of absorptive T-top, Y-top, slanted-top, single-wall absorptive, and absorptive parallel noise barriers are addressed as they compare to a conventional noise barrier. Based on acoustic, aesthetic, and economic impacts, conclusions and recommendations are drawn on the most promising of these special barrier applications for selected WSDOT projects. For each project selected, a standard barrier design was completed, followed by application of the five special treatments.

Because special noise barriers are acoustically superior [Cohn 1993], these barriers provide an alternative to constructing taller conventional noise barriers of similar acoustic performance. Studies have indicated that insertion loss (the net reduction in sound level after construction of a barrier) increases 1 dB for every 2 feet of barrier height as long as an adequate line-of-sight break is maintained [Cohn 1993]. Therefore, noise barrier performance can generally be improved by increasing the height. However, studies have shown that the "benefit/cost ratio generally peaks at a height of about 13 feet" [Cohn 1993, 83].

Special noise barriers offer a viable alternative to constructing taller conventional barriers which adversely affect the surrounding aesthetic environment and raise barrier costs. Because special noise barriers offer increased acoustical performance over a conventional barrier of equal height, special barrier heights could be lowered to reduce negative aesthetic and economic impacts.

Each special noise barrier's enhanced acoustical performance varies due to the different mechanisms these barriers utilize: double diffraction provided by a T-top or Y-top section, movement of the diffraction zone by slanting the upper third height of a conventional barrier, and the application of absorptive material to a T-top section or vertical wall [Cohn 1993]. The following paragraphs discuss the different mechanisms special noise barriers utilize to improve acoustic performance.

T-top and Y-top barriers increase insertion loss through double diffraction, which is similar to placing two conventional noise barriers close to one another. Thus, T-top and Y-top barriers provide acoustic performance similar to that of a knife-edge barrier when the difference in height between the two barriers is equal to the width of the top. Because a Y-top barrier does not have a continuous flat surface to provide interference with the propagating wave during double diffraction, it is less acoustically effective than a reflective T-top. Unlike T-top and Y-top barriers, slanted-top barriers provide only a slight increase in insertion loss when compared to a conventional barrier of equal height, resulting from the increase in path length caused by the movement of the diffraction zone closer to the roadway.

An increase in insertion loss can also be achieved by the application of absorptive material to T-top, single-wall and parallel barriers. Applying absorptive material to these barriers raises insertion losses by absorbing sound wave energy, particularly for higher-frequency sound levels with shorter wavelengths that can be more easily affected while diffracting across the top of the barrier. Because highway traffic noise has a dominant frequency of approximately 550 hertz, resulting in a wavelength approximately 2 feet long [FHWA 1980], a 3-foot absorptive strip was

recommended for the absorptive T-top and single-wall absorptive barriers to ensure adequate absorption. Applying absorptive material to T-top and single-wall absorptive barriers would produce an additional 2 dB of attenuation, while parallel barriers treated with absorptive material would aid in reducing insertion loss degradation resulting from multiple reflections.

Four WSDOT highway projects, three in Seattle (Fourth Avenue, Magnolia Road, and Kent Commons Play Field) and one in Spokane (Spokane Community College Area), were selected to investigate the predicted field effectiveness of absorptive T-top, Y-top, slanted-top, single-wall absorptive, and absorptive parallel barriers. For each project site, a base-line standard barrier design was created to provide an insertion loss of approximately 10 dBA. Applying special noise barriers to each site required modifications in barrier heights in order to provide barriers of similar acoustic performance to the base-line standard barrier designs.

Using the acoustic "rules of thumb" established in this report and the line-of-sight breaks calculated by the Line-of-Sight program, standard barrier design heights were modified in order to apply special barrier applications. Insertion losses were calculated for each modified conventional barrier design using STAMINA 2.0/OPTIMA. The additional insertion loss provided by the application of a special barrier was then added to the insertion losses calculated using STAMINA 2.0/OPTIMA to produce each special noise barrier resultant insertion loss.

An absorptive T-top would provide an additional 4.3 dB of attenuation when compared to a conventional barrier of equal height, resulting from double diffraction and the application of absorptive material. Thus, an absorptive T-top could provide

the same insertion loss as a conventional barrier 8 feet higher. Also, double diffraction results in the Y-top barrier providing an insertion loss (1.3 dB) equal to a conventional barrier 3 feet taller. Single wall barriers would provide a 2 dB increase in insertion loss, producing acoustical performance equal to a conventional barrier 4 feet taller. Unlike the absorptive T-top, Y-top, and single wall absorptive barriers, a slanted-top barrier would not produce any significant increase in attenuation, thus barrier heights should not be reduced. Also, barrier heights should not be lowered for parallel barriers in cases where insertion loss degradation is prevalent due to multiple reflections; instead absorptive material should be applied to these barriers to lessen the negative effects of insertion loss degradation.

Special noise barriers were found to be beneficial to these sites because these barriers provided attenuation similar to a taller conventional barrier. In fact, an absorptive T-top, Y-top, and single-wall absorptive barrier were recommended for project application because these barriers would lessen aesthetic and economic impacts. A slanted-top barrier was also found to be beneficial for highway projects that need to be sensitive to their surrounding aesthetic environment. Also, absorptive parallel barriers are beneficial for sites where insertion loss degradation is present due to multiple reflections.

Selection of a special noise barrier should be based on a barrier's ability to minimize acoustic, aesthetic, and economic impacts, and should be prioritized accordingly to projects on an individual basis. Analyzing the acoustic, aesthetic, and economic impacts of special barrier applications for individual projects will hopefully lead to appropriate barrier selection, and in turn the true effectiveness of these barriers

will be verified. As a result of this research, it is hoped that special noise barriers will be strongly considered as an alternative solution to constructing taller conventional noise barriers.

PROBLEM STATEMENT

During the last 20 years, state highway agencies have constructed more than 500 linear miles of noise barriers in the U.S. Most of these barriers have been vertical, reflective walls made of concrete, wood, or steel with a "knife-edged" barrier top, providing a single diffraction edge with a reflective diffraction zone. Clearly, many other options are available for noise barrier shapes and treatments, including earth berms, absorptive or partially absorptive barriers, barriers with slanted sections at their tops to provide horizontal displacement of the diffraction zone, and barriers with T-tops or Y-tops to provide a double-diffraction zone. A previous study for WSDOT, *Special Noise Barrier Applications: Phase I*, found that five special applications warrant further examination: absorptive T-top barriers, single-wall absorptive barriers, slanted-top barriers, absorptive parallel barriers, and Y-top barriers.

This study examined the potential for implementing each of the five special treatments in four actual highway projects in Washington State. For each highway project, a standard barrier design was completed, and the five special treatments were applied.

OBJECTIVE

A previous study, *Special Noise Barrier Applications: Phase I*, identified five barrier applications that could improve the WSDOT noise mitigation program. The primary objective of this research was to test these five applications analytically on several actual highway projects to gain definitive information on their real potential. Four WSDOT highway noise mitigation projects were selected for use as *field laboratories* for examining the application potential of the special barrier treatments. Three of these highway projects are located in Seattle: Fourth Avenue S.E. and Magnolia Road, both located on SR-405 in King Co. and in South Snohomish Co; and Kent Commons Play Field, located on SR-167. The other project is the Spokane Community College Area, located on the Market/Greene alternative of the planned North Spokane Freeway route.

SPECIAL NOISE BARRIERS

The previous report, *WSDOT Special Noise Barrier Applications: Phase I*, recommended that five special noise barrier treatments, including shaped tops and absorptive surfaces, be considered for WSDOT highway projects. The recommended barrier treatments are listed below and are described in greater detail in the following sections of this report.

Shaped Barriers:

1. Absorptive T-top
2. Y-top
3. Slanted-top

Absorptive Barriers:

1. Single Wall Absorptive
2. Absorptive Parallel

Shaped Barrier Tops

The performance of noise barriers can generally be improved by increasing their height. However, studies have shown that the "benefit/cost ratio generally peaks at a height of about 13 feet" [Cohn 1993, 83]. In addition, increasing the height of barriers diminishes the view of the surrounding environment, causing a negative aesthetic impact. Researchers have found that shaped barriers can achieve enhanced acoustical performance without increased height, thus minimizing the negative

aesthetic impact. Therefore, shaped barriers provide an alternative for highway projects with conventional barrier heights of 13 feet or more, and such barriers should be considered for WSDOT projects.

Absorptive T-top Barriers

An absorptive T-top barrier is formed by placing a horizontal section treated with an absorptive application on the top of a vertical wall. Past studies have shown that the insertion loss (the net reduction in sound level after construction of a barrier) achieved by an absorptive T-top barrier is significantly greater than that achieved by a conventional barrier of the same height. The insertion loss increases because the absorptive treatment absorbs sound wave energy and the T-top section produces double diffraction, similar to that caused by placing two conventional knife-edged barriers close to one another. Thus a reflective T-top barrier provides acoustical performance similar to that of a knife-edged barrier when the difference in height between the two barriers is equal to the width of the T-top.

Applying an absorptive treatment to the T-top also increases insertion loss, particularly for higher-frequency sound levels with shorter wavelengths that can be more easily affected while diffracting across the top of the barrier. Highway traffic noise contains energy in frequency bands throughout the audible range, but the dominant frequency is approximately 550 hertz, resulting in a wavelength roughly 2 feet long. Therefore, to ensure the optimum acoustical performance of the absorptive treatment, a cap width of 3 feet should be used for absorptive T-top barriers selected

for WSDOT projects. Figure 1 displays the configuration of the absorptive T-top barrier.

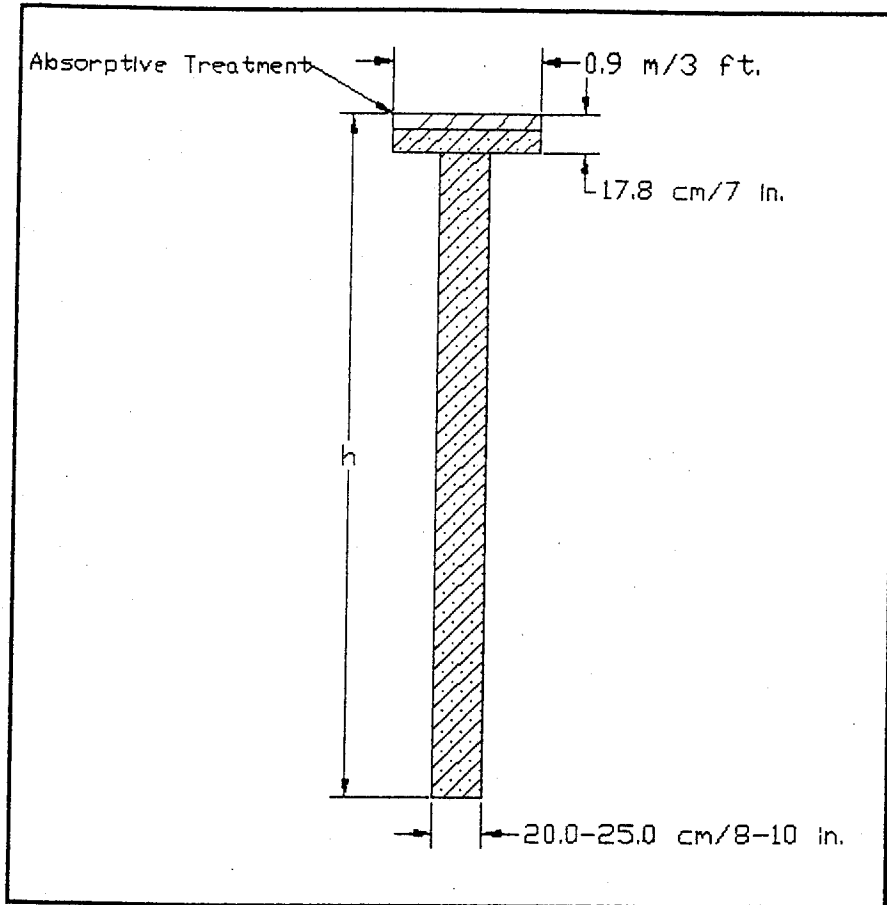

FIGURE 1 - Absorptive T-top Barrier

Y-top Barriers

Another shaped barrier under consideration for WSDOT projects is the Y-top barrier. Like the T-top barrier, the Y-top barrier also provides increased acoustical performance through double diffraction. However, unlike the T-top barrier, the ends of the horizontal section at the top of the vertical wall are not flat, but rather are

slanted upward in the shape of a Y. Because the Y-top barrier does not have a continuous flat surface to provide interference with the propagating wave during double diffraction, it is acoustically less effective than a reflective T-top barrier. Nevertheless, the Y-top barrier provides better acoustical performance than a conventional barrier more than 13 feet in height. Like the absorptive T-top, because of the dominant frequency of highway traffic noise, the Y-top should have a width of 3 feet to facilitate double diffraction at both ends of the Y-top section. The Y-top barrier is depicted in Figure 2.

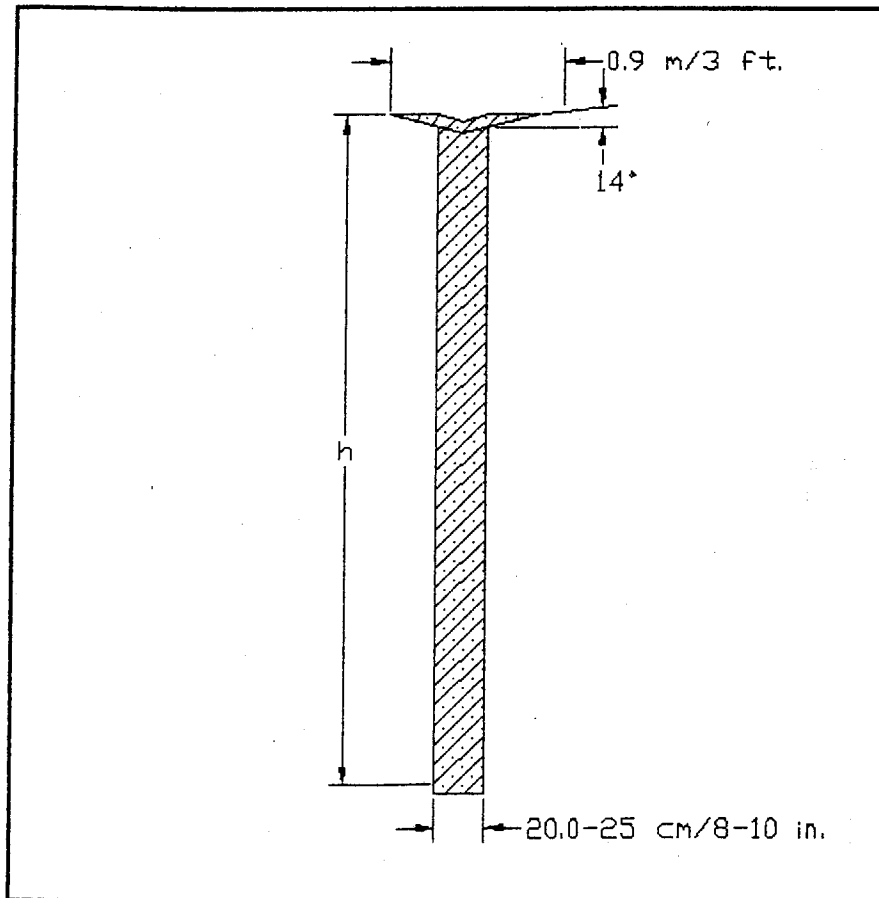

FIGURE 2 - Y-top Barrier

Slanted-top Barriers

The final shaped barrier selected for analysis is the slanted-top barrier, formed when the upper one-third of the barrier is slanted toward the traffic at an angle of 30 to 45 degrees. Slanting the top of a barrier displaces the location of the diffraction edge, resulting in an increase in path length and improved barrier performance. The slanted-top barrier is displayed in Figure 3.

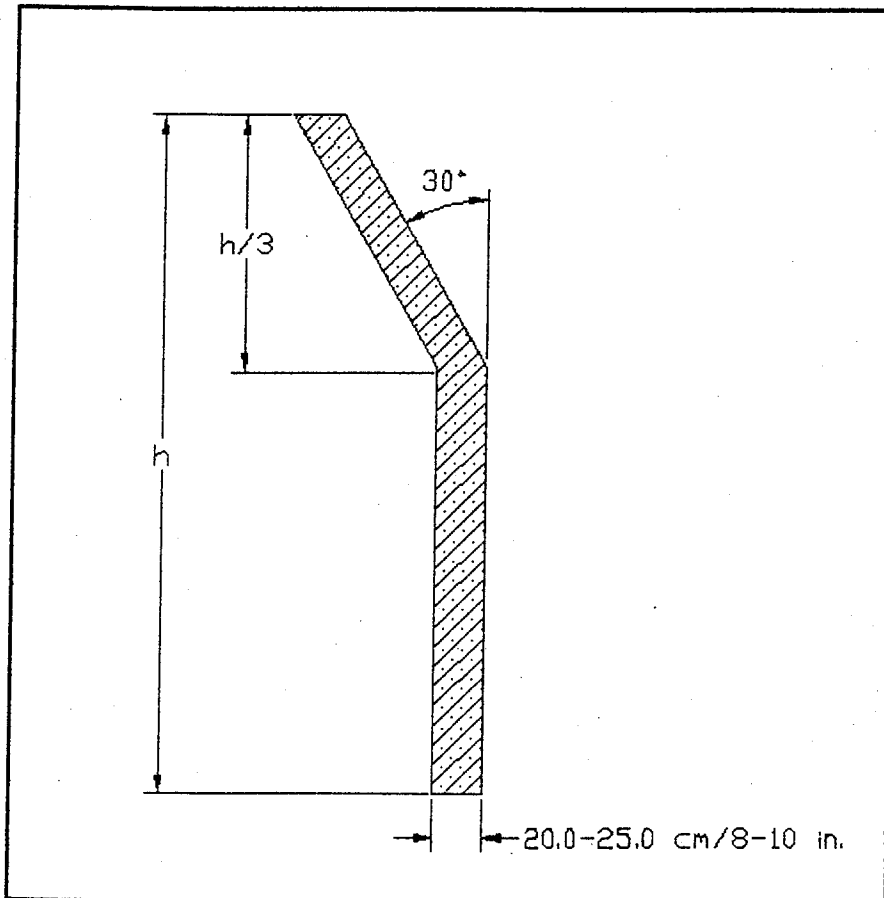

FIGURE 3 - Slanted-top Barrier

Absorptive Noise Barriers

Like shaped barriers, absorptive barriers enhance acoustical performance without increasing barrier heights. Absorptive barriers are formed by placing absorptive strips on the upper zone of a noise barrier. These strips should be 3 feet in length to ensure adequate absorption of sound waves. Depending upon the amount of acoustical performance desired, the absorptive treatment can be placed on the receiver side, the source side, or both sides of the barrier. Nicolas *et al* concluded that an absorbent covering will give the same increase in insertion loss if it is placed on either the source side or the receiver side. This study also found that covering both sides of a barrier increases the insertion loss, especially when both the receiver and the source are located near the barrier [1989].

Although absorptive noise barriers have been extensively studied for many years [Cohn 1993], the results of these studies have been inconclusive. Absorptive treatments absorb high-frequency noise better than they absorb low-frequency noise. The two absorptive noise barriers considered for WSDOT projects are single-wall absorptive barriers and absorptive parallel barriers.

Single-Wall Absorptive Barriers

Placing an absorptive treatment on a single-wall barrier increases the insertion loss of the barrier [Cohn 1993]. Thus, a shorter barrier with an absorptive treatment

provides acoustic performance similar to that of a taller conventional barrier while at the same time decreasing negative aesthetic impact.

Absorptive Parallel Barriers

When reflective parallel barriers are used, multiple reflections of sound can degrade the acoustical performance of each wall, particularly when the canyon width is less than 200 feet, the barriers are at least 10 feet high, the ratio of canyon width to barrier height is less than 20:1, and the barriers are perfectly parallel and equal in height. Under these conditions, absorptive parallel barriers can be used to reduce the number of multiple reflections [Bowlby 1987], thereby decreasing the degradation in insertion loss. Therefore, the application of absorptive material is recommended for parallel barriers 10 feet or more in height. An illustration of parallel barriers with multiple reflections is presented in Figure 4.

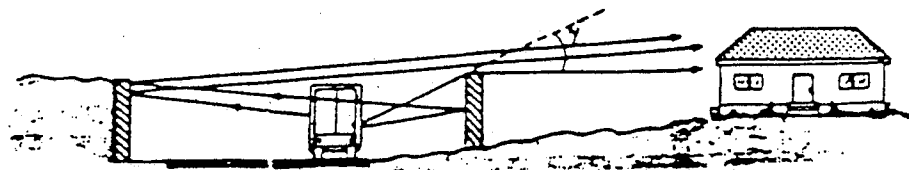

FIGURE 4 - Parallel Barriers

SPECIAL NOISE BARRIER FEASIBILITY AND IMPACTS

This study reviewed the unique feasibility and impact (acoustic, aesthetic, and economic) of each of the five recommended special barrier applications to determine whether they are appropriate for use in WSDOT projects. In some instances, the special noise barriers may be superior in every way to conventional barriers.

Acoustic Feasibility

Under certain circumstances, special noise barriers perform better acoustically than conventional barriers. These circumstances were examined to aid in selecting the appropriate barrier for an individual site.

One limitation in the application of special noise barriers is line-of-sight breaks. A line-of-sight break is the difference between the height of the barrier and the distance at which the line of sight intersects with the barrier. Figure 5 gives a visual explanation of a line-of-sight break. To maintain an adequate line-of-sight break, a special noise barrier must be at least 2 feet through the line of sight [Cohn 1993]. As long as a 2-foot line-of-sight break is maintained, the height of a conventional barrier could be reduced by the use of a shorter special noise barrier.

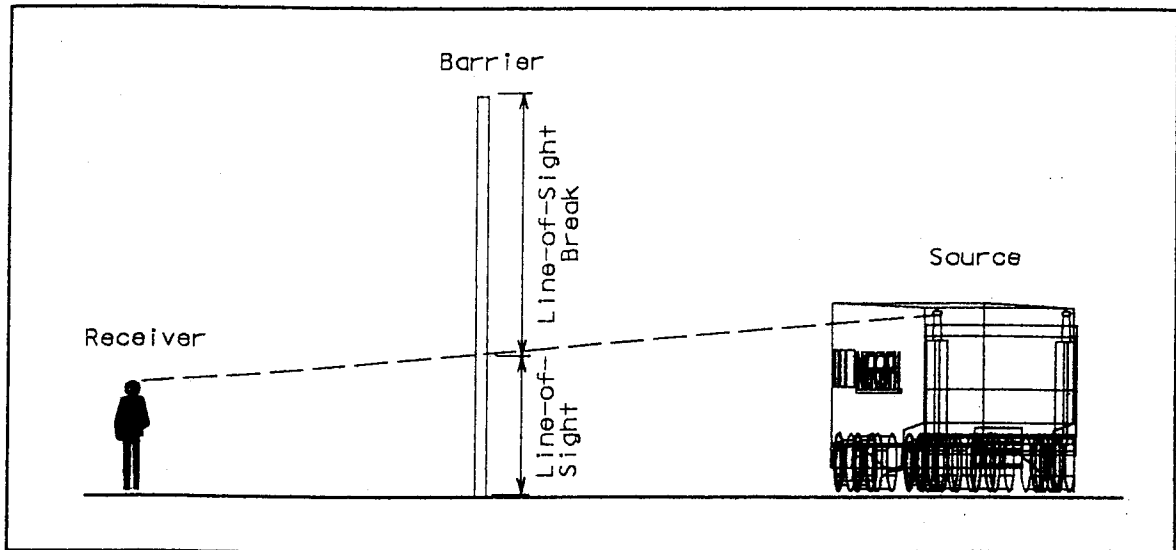

FIGURE 5 - Line-of-Sight Break

Special noise barriers are not recommended for some conventional barrier heights. Shaped-barrier tops are applicable when barrier heights exceed 13 feet because the benefit/cost ratio generally peaks at this height. However, if line-of-sight breaks are maintained, increased acoustical performance can be achieved regardless of barrier height, and single-wall absorptive barriers are recommended. Absorptive materials could be applied to almost any WSDOT project with single-wall barriers. Unlike single-wall absorptive barriers, absorptive parallel barriers are limited to barriers taller than 10 feet, because only at this height will multiple reflections cause significant insertion loss degradation, warranting the application of absorbent materials.

In addition, the amount of attenuation needed for a particular barrier height should be considered. The five special noise barriers under consideration offer

differing amounts of insertion loss over a conventional barrier of the same height. Therefore, special noise barriers should also be selected on the basis of the amount of acoustical performance needed for a particular site. The acoustical performance of each special noise barrier is presented in this report.

Acoustic Impacts

The acoustical performance of each special noise barrier is different because each provides increased insertion loss through a different mechanism: double diffraction (T-top and Y-top barriers), displacement of the diffraction edge (slanted-top barriers), and absorptive treatments (T-top sections, single-wall barriers, and parallel barriers). To determine the acoustical performance of each special noise barrier, the information presented in the previous report, *WSDOT Special Noise Barrier Applications: Phase I*, was expanded to establish acoustic "rules of thumb," which were used to calculate the insertion losses provided by each application.

Absorptive T-top Barrier

For the reasons discussed earlier in this report, T-top barriers with 3-foot caps were selected for WSDOT projects. To calculate an insertion loss for these caps, a linear relationship between insertion loss and cap width was assumed. This assumption provided a reasonable approximation of insertion loss for caps of varying widths. Because the cap widths differ by only a few feet, this assumption should be

valid. The acoustical performance of the absorptive T-top barrier was determined by applying the following "rules of thumb" from the Phase I report:

May and Osman determined that an absorptive T-top with a cap width of 2 feet results in an additional 1.9 dB of attenuation when compared to a reflective T-top with the same cap width [1980-1]. The amount of additional attenuation an absorptive T-top barrier could provide in comparison to a reflective T-top barrier was calculated as follows on a per-foot cap width basis:

$$1.9 \text{ dB}/2 \text{ foot cap width} = 0.95 \text{ dB/foot of cap width}$$

For a 3-foot cap width, the additional attenuation the absorptive T-top provides when compared with the reflective T-top results in the following:

$$0.95 \text{ dB/foot of cap width} * 3 \text{ feet} = 2.8 \text{ dB}$$

In addition to the two previous calculations, a comparison between the acoustical performance of a reflective T-top barrier and that of a conventional barrier was determined to develop an acoustical performance relationship between an absorptive T-top and a conventional barrier. The acoustical performance between a reflective T-top and a conventional barrier is based upon the "rule of thumb" that the increased performance resulting from the reflective T-top is at least equivalent to that which would result if the T-top

section were stood on its end and added to the height of the vertical section of the barrier. Therefore, insertion loss increases 1 dB for every 2 feet of height beyond the line-of-sight break as long as an adequate line-of-sight break is maintained. A reflective T-top noise barrier with a 3-foot cap width may provide the following additional attenuation in comparison to a conventional barrier of equal height:

$$1 \text{ dB}/2 \text{ foot} * 3 \text{ foot cap width} = 1.5 \text{ dB}$$

Adding the two previous calculations resulted in the following additional attenuation for an absorptive T-top with a 3-foot cap width when compared with a conventional barrier of equal height:

$$2.8 \text{ dB} + 1.5 \text{ dB} = \underline{4.3 \text{ dB}}$$

Therefore, an absorptive T-top barrier could achieve the same insertion loss as a conventional barrier 8 feet higher as long as the line-of-sight break was maintained. Reducing the height of a conventional barrier by 8 feet would significantly minimize negative aesthetic impacts. Therefore, in some instances tall conventional barriers could be lowered and capped with absorptive T-tops.

Y-top Barriers

The amount of additional attenuation provided by a Y-top barrier was calculated by applying the "rule of thumb" found in the Phase I report. Like that of the absorptive T-top barrier, the insertion loss of the Y-top barrier was determined by assuming a linear relationship between insertion loss and span width. The insertion loss for a 3-foot wide Y-top was calculated as follows:

May and Osman found that a Y-top barrier with an 8-foot span provides 3.5 dB of additional attenuation when compared with a conventional barrier [1980-1]. A Y-top barrier with a 3-foot span, then, would produce the following additional attenuation in relation to a conventional barrier of equal height:

$$3.5 \text{ dB}/8 \text{ foot span} = 0.438 \text{ dB/ foot of span}$$

$$0.438 \text{ dB/foot of span} * 3 \text{ feet} = \underline{1.3 \text{ dB}}$$

The calculated insertion loss of 1.3 dB means that the same insertion loss provided by a conventional barrier could be achieved by a Y-top barrier approximately 3 feet shorter. Thus, Y-top barriers should be considered when tall conventional barriers need to be shortened.

Slanted-top Barriers

Since a slanted-top barrier enhances acoustical performance through displacement of the diffraction edge, the acoustical performance of this type of barrier was determined by STAMINA/OPTIMA. Because of limitations in the STAMINA/OPTIMA program, a direct model of slanted-top barriers could not be created. Therefore, the barrier location was moved closer to the roadway to simulate the displacement of the diffraction edge produced by a slanted-top barrier.

Two data files were created for STAMINA/OPTIMA to model slanted-top barriers. The first data file included two 2000-foot, parallel roadways spaced 50 feet apart, a 2000-foot, 12-foot high barrier spaced parallel and 50 feet from the roadways, and receivers placed in a line 50, 100, 150 feet away from and perpendicular to the middle of the barrier. Other input parameters were a 60 mph vehicle speed, a volume of 4000 vph with heavy and medium truck percentages of 5 and 3 percent, respectively, $\alpha=0.5$, and a shielding factor of zero. Except for the placement of the barrier 5 feet closer to the roadways, the second data file was exactly like the first. The results of the STAMINA/OPTIMA modeling indicated the acoustical performance of a slanted-top barrier is approximately equal to a conventional barrier. The OPTIMA output is presented in Table I on page B-1.

Single-Wall Absorptive Barriers

The Ph.D. dissertation Performance of Absorptive Treatments for Single Highway Noise Barriers [Kim 1992] discussed the additional attenuation provided by applying absorptive treatments to noise barriers. Dr. Kim stated that placing an absorptive treatment one wave length from the top of the barrier resulted in up to an additional 4 dBA of attenuation in the shadow zone. The additional attenuation provided by the absorptive treatments decreases as the distance between the barrier and the receiver increases. Therefore, 2 dBA of attenuation was considered as the acoustic "rule of thumb" for this report.

Absorptive Parallel Barriers

Multiple reflections degrade the insertion loss of parallel barriers. In fact, the insertion loss of parallel barriers is decreased by approximately 2 to 4 decibels if the width of the canyon is less than 200 feet, the height of the barrier is at least 10 feet, the ratio of canyon width to barrier height is less than 20:1, and the barriers are perfectly parallel and of equal height [Cohn 1993]. Under such circumstances, benefit can be gained by applying absorbent material to these barriers, thus reducing the negative effects of multiple images [Bowlby 1987] and reducing insertion loss degradation.

REBAR, a program included in the *Noise Software Library* of the University of Louisville, was developed to calculate the amount of insertion loss degradation caused

by the numerous image sources created by multiple reflections. This software program allows the designer to examine the effects of parallel barriers without performing burdensome calculations. In this study, REBAR was used to determine the decrease in insertion loss associated with the multiple reflections of parallel barriers. Table II on page B-2 shows the decrease in insertion loss calculated by REBAR for the Spokane Community College Area's reflective and absorptive parallel barrier designs.

Aesthetic Feasibility

Because public acceptance of barrier designs is crucial to the success of most projects, the aesthetic impact of the barriers is a very important consideration in the design process. To gain positive public perception, most state highway agencies are forced to design beyond their specified design noise level criteria and to develop designs that "match and harmonize with established architectural features" [Hurd 1987].

Five concepts should be investigated to determine whether the barrier design will achieve harmony with the surrounding community:

1. Barrier Size and Mass
2. Material Selection
3. Landscaping
4. Color
5. Citizen Involvement [Cohn 1981]

Increasing the size and mass of a barrier improves its performance. However, the "benefit/cost ratio generally peaks at around 13 feet" [Cohn 1993]. Because special noise barriers are shorter than conventional barriers, they can have a very positive aesthetic impact.

An important aesthetic consideration is selecting the proper materials for the final design of the barrier system. Some states have performed social surveys to gauge the perceived effectiveness of different types of barriers [Cohn 1981]. The results, presented from most favorable to least favorable, are shown below.

1. Earth Berm
2. Wall-Berm Combination
3. Wood or Concrete (tie)
5. Metal

Berms are very acceptable because they blend in and are perceived to be part of the natural highway environment. However, "large areas of right-of-way are required for mounds of significant height" [Simpson 1976], and it may not be possible to obtain enough land to construct a berm in an urban or suburban area. On the other hand, a wall-berm combination requires less land and results in a shorter wall that is perceived as less offensive by neighboring communities.

The results of the social survey cited above indicated a tie in the acceptability level of wood and concrete. In naturally wooded regions with abundant vegetation, a wooded barrier harmonizes with the natural setting, and such a barrier can also match the privacy fences located in many suburban areas. Concrete can be molded to resemble wood panels or shaped into other configurations that harmonize with

established architectural features [Hurd 1987]. Surface coloring also helps concrete barriers blend with their surroundings. Pigments may be added to concrete mixes to obtain a color suitable for the project. The use of earth-toned colors (light browns, etc.) is encouraged because these colors look more attractive than regular Portland cement concrete and do not attract unwanted attention to the barrier [Hurd 1987].

Landscaping also enhances the ability of the barrier to blend into its environment. For instance, the use of separate posts and panels in a vegetative environment lends the appearance of wood. One study found that effective landscaping can raise the perceived effectiveness of the barrier by a psychological attenuation of 7 dBA [Cohn 1984].

The people surveyed found metal an unpopular choice of material for barrier construction, in part because of its maintenance disadvantages. Metal requires more frequent painting and treatment with chemicals to inhibit rusting. These maintenance costs can be considerably larger than those associated with a tinted concrete barrier [Hurd 1987].

Public involvement in barrier development is crucial to a highway noise barrier project. The following are some of the issues raised by the public about the placement of noise barriers along highways:

1. Why spend so much on so few?
2. Why should I pay for someone else's comfort?
3. They make the highway ride noisier.
4. They make driving monotonous.
5. They block scenery.
6. Barriers are eyesores [Cohn 1981].

Complaints such as these illustrate the necessity of public involvement in the barrier design process. "If the public believes it played a legitimate role in barrier development, it will receive the final design in a more favorable light" [Cohn 1984].

After a particular barrier design has been found to be compatible with a certain project, the acceptability of the design must be determined. Acceptability will be affected by several issues, each of which has pros and cons.

- Pros:
1. Greater sense of privacy.
 2. Perception of increased security from the drivers of vehicles that have broken down or from other intruders.
- Cons:
1. Blocking view of road or from road.
 2. Blocking breezes.
 3. Blocking sunlight from gardens [Bowlby 1992].

Special noise barriers can enhance the aesthetic quality of the barrier design, while at the same time diminishing or eliminating negative impacts. Because special noise barriers are designed to be acoustically more effective than conventional barriers, barrier height can be reduced, thus decreasing costs and barrier mass for a given project.

Aesthetic Impacts

Special barrier applications not only reduce noise levels but also reduce the height of the barriers, making the barriers more aesthetically pleasing and acceptable to adjacent communities because the appearance of encroachment on adjacent properties is lessened. Shorter barriers provide some privacy and a sense of security for residences near the roadway, but they do not block as much sun or affect natural air ventilation as much as conventional barriers. This report discusses five special barrier applications that could improve the aesthetics of the barrier design.

Absorptive T-top, Y-top, single-wall absorptive, and absorptive parallel barriers are more aesthetically pleasing because they can provide increased attenuation with less height than conventional barriers. Slanted-top barriers also offer some aesthetic enhancements; slanting the upper third of the barrier away from the receiver allows more sunlight to reach nearby residences and makes the barrier seem to encroach less upon the affected receivers. However, this type of barrier may present an unwanted obstacle on the roadway by causing the appearance of constricted lateral clearance, resulting in reduced flow rates and capacity [McShane 1990].

Economic Feasibility

To develop a complete evaluation of these special noise barriers, this study addressed the economic impacts associated with each type of special barrier. The ultimate goal of any barrier design is to maximize noise reduction while minimizing cost [FHWA 1982]. It is assumed that reducing barrier heights will ultimately reduce barrier costs, thereby optimizing the placement of barriers adhering to WSDOT feasibility criteria.

Most of the costs associated with any barrier design are the result of initial construction and continued maintenance, and different structural and maintenance requirements are associated with each type of special noise barrier. These requirements include the cost of materials and construction, resistance to environmental conditions, durability, and ease of repair and maintenance [Hayek 1990]. Other costs that could influence the price of a barrier include labor, the cost of transporting materials, foundation requirements depending on soil types, and prevailing economic conditions [Bowlby 1992].

Although special barriers offer increased attenuation over conventional barriers, the maintenance and structural considerations associated with each type of barrier will affect its economic feasibility for each of the WSDOT projects. The following sections of this report examine important economic elements that could affect the selection of a special noise barrier.

Structural Considerations

Because noise barriers are subjected to wind loads, they must be designed to effectively resist these loads. Wind load dictates the strength requirements of the posts used in most barrier designs, and these posts are a significant component of barrier costs [Cohn 1993]. Steel reinforcements are needed in these posts to take up the stress as the panels rock back and forth [Bowlby 1992]. In addition, the design criteria for barrier foundations are based on the expected wind loads of a particular geographic area. For example, barriers that might experience hurricane force winds will need a stronger foundation to resist these excessive loads. Such foundation requirements could become quite expensive.

Many different design criteria for noise barrier construction have been used across the U.S. to ensure structural stability. Some of the design specifications used are the *AASHTO Standard Specifications for Structural Support for Highway Signs, Luminaries, and Traffic Signals*, local building codes, and the *1989 Guide Specifications for Structural Design of Sound Barriers*. The *Guide Specifications for Structural Design of Sound Barriers* provided consistent criteria for the construction of noise barriers while allowing the designers some flexibility in the choice of the final design [Bowlby 1992]. Some agencies use a combination of these design specifications.

State DOTs have developed their own noise barrier programs to deal with the unique problems and goals of their individual states. For instance, the particular geology of a state may call for better footings to control settlement, etc. *The Guide on*

Evaluation and Attenuation of Traffic Noise discussed examples of barrier designs from three states. One state used the AASHTO guidelines; another state used local building codes; and the third state used a combination of the two design techniques. The study concluded that the design criteria had been too conservative and that the "least conservative design has had excellent results without compromising the structural design of the noise walls" [AASHTO 1984].

Most areas of the country have building codes for bridges and regulations to ensure compliance with these codes. Bridges offer different challenges for designing noise barriers, including wind loading, methods of attachment, and weight and safety. Wind loading is always a concern in the stability of a structure. Because wind loads cause the deck of a bridge to bend, the connections used to attach the noise barriers to the bridge are crucial and must be strong enough to resist this bending movement. Additionally, the weight and safety of a barrier must be considered early in the design process, especially if the barrier is to be constructed on an existing bridge. The bridge may not have been originally designed to accommodate the additional weight and new wind loads associated with the noise barrier; thus the safety of the bridge comes into question.

Barriers on bridges must be designed to be safe for traffic using the bridge. If possible, the barrier should be light and elastic and should be slanted away from the road to decrease the possibility of contact between vehicles and barriers. Such contact could damage the barrier or cause injuries to motorists.

Hajek and Blaney stated that foundation requirements usually do not favor increases in barrier heights [1984]. Therefore, special noise barrier applications offer

some structural advantages over conventional barriers of equal performance, primarily in the area of height reduction. Reducing the height of the barrier decreases wind loading, thus lowering foundation requirements. However, T-tops could create a pocket that may cause more wind problems.

Absorptive T-top Barriers need some additional supports and ties to ensure a solid connection between the cap and the barrier. These added costs could be offset by the reduction in barrier height and by decreased foundation requirements.

Y-top Barriers require some added support at the top of the barrier. The foundation requirements for a Y-top barrier are lower, but the Y-top may create other problems. For example, the accumulation of debris in the Y-top could block drainage and cause water to pond on the surface of the Y-top, adding weight to the barrier. Correcting this problem would require drilling large drainage holes in the barrier or manually removing debris from the Y-top, both of which would increase maintenance costs.

Slanted-top Barriers require extra support and stronger foundations to help hold the slanted, upper third of the barrier. Because the slanted-top barrier offers little additional attenuation over a conventional barrier, the added costs of its structural requirements are only justified when aesthetics are crucial to a community's acceptance of a noise barrier design.

Absorptive Barriers are conventional barriers with an absorptive strip placed along their top edge. Depending on the type of absorptive material chosen, the complexity of the support and attachment required may vary. For example, the absorptive strip may be glued or nailed to a barrier, or absorptive material could be incorporated into the barrier itself (i.e., absorptive aggregate). Absorptive barriers improve acoustical performance and encourage reduction in the height of barriers, thus reducing foundation requirements.

Maintenance Considerations

Maintenance factors influence the construction costs of special noise barriers and should be considered when analyzing the overall economic impact associated with a special barrier application. Currently, state highway agencies provide only limited data about the maintenance costs of highway barriers [Bowlby 1992]. Therefore, this report discusses the elements that could increase the costs of each special noise barrier under consideration, such as the durability of the materials used, the cost of removing accumulated debris, and the periodic maintenance required. Because many variables affect the maintenance costs of a barrier, it is difficult to determine the exact costs for individual sites. The following sections of this report examine significant maintenance elements that could affect the selection of a special noise barrier.

The most important maintenance factor that can inflate the cost of a special noise barrier is the durability of the materials used, because this factor has a significant impact on the service life of the barrier. Therefore, the types of materials

used should be considered carefully to prevent the need for replacement. For example, many states have experienced problems with the durability of wooden barriers, including rotting, warping, racking, and shrinking. Nevertheless, the wooden materials used in barriers react differently in different environments, and the use of wooden barriers could be appropriate in certain areas of the country [Bowlby 1992]. Stockpiling spare parts should be considered to facilitate the replacement of damaged barrier sections.

In the case of barriers treated with absorptive material, special attention should be given to the selection of a particular treatment. The durability of absorptive treatment when exposed to seasonal weather conditions, such as severe freeze-thaw cycles, has not been proven. Absorptive barriers should also be resistant to acts of vandalism, impacts from vehicles, and the presence of chlorides from snow plowing operations and spray. The previous report (Phase I) found that one absorptive treatment, Durisol, provides adequate durability. Durisol is a concrete-based material that uses wood chips (as an absorbing agent) pressed into the mix. A Durisol product literature states that the Durisol material achieves a noise reduction coefficient of between 0.75 and 0.85.

In addition to the durability of materials used, another factor affecting the costs of barrier maintenance is debris accumulation. Removing debris is essential to preserving the structural integrity of a barrier. For shaped barrier tops, periodic removal of debris should be included in maintenance costs. For instance, the flat top of an absorptive T-top barrier may collect debris, including snow. Varying the thickness of the flat T-top to produce a sloped surface can reduce the frequency with

which debris removal is required. Y-top barriers also require debris removal, because the Y-top shape produces a channel on top of the barrier in which debris is apt to collect. If periodic removal of debris is not performed, drainage holes will be plugged, and standing water will result. Additionally, it may be necessary to remove snow from the trough of the Y-top.

Other periodic maintenance requirements will be associated with any type of noise barrier, including removal of graffiti, repair of damage caused by vehicle accidents and snow removal equipment, and repair of the normal deterioration of a noise barrier (such as fading of color) caused by exposure to the surrounding environment. Removing graffiti from barrier walls requires sandblasting or painting and increases maintenance costs. Two methods developed by various states to combat graffiti on barrier walls are roughing textured surfaces and planting vegetation [Bowlby 1992].

Maintenance to areas between the right-of-way line and the barrier should also be considered. These areas may require periodic landscaping and trash removal. To reduce landscaping maintenance, some states have planted low-maintenance vegetation in these areas. A few states have granted title to property owners behind the barrier wall to shift the landscaping responsibilities from the state to the homeowner [Bowlby 1992].

Economic Impacts

To assess the costs involved in the construction of special noise barriers, the authors of this report contacted several contractors to obtain a comparison of the costs of conventional barriers and special barriers of equal acoustical performance.

One of the contractors interviewed was Highway Structures, Inc., which was responsible for constructing many highway noise barriers along I-264 in Louisville, Kentucky. This company provided cost estimates for various types of barriers constructed from prestressed, prefabricated concrete panels, with posts spaced approximately 40 feet apart. The following is a list of approximate increases in costs of special barriers as compared to the costs of a comparable conventional barrier of the same height (represented by a factor of 1.00).

HIGHWAY STRUCTURES INC. (PRE-STRESS)

Barrier Type	Cost Factors
Conventional	1.00
Slanted Top	1.273
Y-top	1.363
Absorptive T-top	1.182 + cost of absorptive material
Single-wall Absorptive	1.00 + cost of absorptive material

Bornstein Building Co., Inc., also provided estimates for the special barriers. These estimates were given as unit costs based on 100-linear-foot, cast-in-place, reinforced concrete with conventional formwork.

BORNSTEIN BUILDING CO. (CAST-IN-PLACE)

Barrier Type	Cost Factors
Conventional	1.00
Slanted Top	1.41
Y-top	1.53
Absorptive T-top	1.41 + cost of absorptive material
Single-wall Absorptive	1.00 + cost of absorptive material

It is easy to see that special barriers of prestressed concrete panels are proportionally less expensive to construct than special barriers built with conventional formwork. The conventional formwork appears to be more labor intensive, and there is less quality control on the materials used in conventionally formed concrete. A future project may include a more detailed comparison of the differential costs between prestressed and formed-in-place concrete.

The firm de AM-RON Building Systems, Inc., of Owensboro, Kentucky, a manufacturer of precast, prestressed concrete, provided an approximate price list of the individual panels based on square-foot units. The price list is as follows:

1. Flat Soundwall Panels	\$ 5.50
2. Slanted-top Panels	\$ 8.25
3. T-top Panels	\$ 9.63
4. Y-top Panels	\$ 11.00

It should be noted that these costs are for only one square foot of material and do not include transportation and construction costs. Also, the de AM-RON representative stated that the Y-top design is impractical from a manufacturing standpoint and would have to be formed in place.

Absorptive barrier costs were based on the use of the absorptive treatment Durisol, manufactured and marketed by the Fanwall Corporation. Discussions with a Fanwall representative suggested that the cost of this absorptive treatment would be an additional \$7 per square foot.

STANDARD BARRIER DESIGN

After the acoustic, aesthetic, and economic impacts of each special noise barrier had been analyzed, the next task was to create a baseline, standard barrier design for the four individual projects selected for analysis. The acoustic, aesthetic, and economic performance of each special barrier design was measured against that of standard barrier designs. Such a comparison will allow the appropriate selection of a special noise barrier for the four WSDOT projects under consideration:

- Seattle:
 - 1. Fourth Avenue S.E.
 - 2. Magnolia Road
 - 3. Kent Commons Play Field

- Spokane:
 - 1. Spokane Community College Area

Because no current methodology can predict the effects of shaped barriers on highway noise, the adjustments or "rules of thumb" discussed earlier were applied to vertical, reflective, knife-edged barriers. The acoustical performance of a shaped barrier was determined by adjusting vertical, reflective barriers and L_{eq} values predicted by STAMINA 2.0/OPTIMA.

STAMINA 2.0 and OPTIMA Modeling

Noise Software Library

The standard, conventional barrier design was accomplished by using the *Noise Software Library* at the University of Louisville. Software programs included STAMINA 2.0, OPTIMA, AUTOBAR, LOS (Line-of-Sight), and REBAR. STAMINA 2.0 is the 1982 version of the FHWA noise prediction model, modified to include the new WSDOT vehicle emission levels. STAMINA creates an output file that becomes an input file for OPTIMA and AUTOBAR. AUTOBAR is an automated barrier design algorithm that interacts with OPTIMA to reach design criteria that were established by the user. LOS determines the line-of-sight elevations at the location of the proposed barrier between a receiver and a specified source height. REBAR calculates the amount of insertion loss degradation associated with parallel barriers.

Modeling Procedures

The first task consisted of drawing and labeling roadways, receivers, and barriers on the plan sheets. After all points were labeled, a MICRO-STATION INTERFACE was used to electronically generate X-Y coordinates for each of the roadway, barrier, and receiver points. This interface then saved the digitized data in a format required by STAMINA 2.0.

The elevations (Z-coordinates) were entered into the data files via STINPUT, a program that allows the manual entry of data into individual data files. The elevations were obtained from either contour maps, cross section sheets, or profile sheets. STINPUT was used to enter other information into the data files. Roadway segments with positive grades were marked in the files because heavy trucks generate more noise when they are traveling along uphill grades. Vehicle traffic and speed data were recorded. Delta-Z values of 2.0, with perturbation values of 3, were placed into the files to provide AUTOBAR with design parameters that limit the number of iterations performed while attempting to satisfy design criteria.

Besides the data mentioned previously, assumptions were made concerning the remaining data file parameters. Noise attenuation caused by hard-site and soft-site conditions was accounted for by entering the appropriate alpha factors.

After all four data files had been completed, STAMINA 2.0 was executed for each of the selected sites to predict no-barrier and barrier L_{eq} values and barrier insertion loss. AUTOBAR was then used to recommend baseline barrier heights. These barrier heights were then compared with the WSDOT barrier height recommendations listed in the reports. The final OPTIMA runs were used to compute receiver L_{eq} values, barrier heights, and square footage for each barrier design.

Finally, LOS was used on each of the final barrier designs. A fundamental rule in noise mitigation states that the line-of-sight between a receiver and a source must be broken to achieve significant noise reduction. The LOS files presented the line-of-sight elevations that were used to determine which special barrier applications were practical for each site.

REBAR was used to calculate insertion loss degradation associated with parallel barriers. Insertion loss degradation was calculated for both reflective and absorptive parallel barriers.

For each of the sites modeled, the resulting data, OPTIMA, and LOS files were bound separately from this report so WSDOT personnel could view the information Louisville used to create each standard barrier design. A document entitled *Barrier Design Files-Supplement to Special Noise Barrier Applications: Phase II* presents the data, OPTIMA, and LOS files.

Previous studies have indicated that modeling accuracy is related to the selection of appropriate reference mean emission levels. In fact, a published study by Harris entitled "Determination of Effectiveness of Noise Barrier Along I-285, Atlanta" found that STAMINA tends to over predict highway noise levels [1982]. Another article published by Harris, "Determination of Reference Mean Emission Levels in Georgia," investigated the possibility that this tendency to over predict is attributable to the selection of the reference mean emission levels. The FHWA version of STAMINA 2.0 uses reference mean emission levels developed in 1975 after a Four-State Noise Inventory conducted by the FHWA. Since this inventory was conducted in such a limited geographic region, Harris suggested that the FHWA reference mean emission levels may not be applicable to every state [1984]. Therefore, to accurately model the four sites selected for WSDOT projects in this report, both the emission levels published by the FHWA in 1975 and the 1993 Washington State reference mean emission levels were used. A comparison between the two noise predictions for each project is displayed in Tables III-VI on pages B-4-B-7.

For the Spokane Community College Area and Kent Commons, no-barrier and barrier L_{eq} values obtained by using the 1975 FHWA reference mean emission levels were 0.6 to 1.5 dBA greater than the results obtained by using 1993 Washington State emission levels. In contrast, for the other two projects, Magnolia Road and Fourth Avenue SE, the no-barrier and barrier L_{eq} values obtained by using the 1975 FHWA levels were not significantly different (less than ± 0.5 dBA) than those obtained by using the 1993 Washington State emission levels.

Seattle Projects

For each WSDOT project, the first task was assembling the necessary data for STAMINA 2.0 and OPTIMA modeling. Data for the Seattle projects included roadway design plans, topographic maps, cross sections, noise reports, traffic data, and photographs of the areas to be investigated. This information, along with aerial photographs, was used to create input files for use in computer-aided design and analysis. A brief description of each site is presented below.

Fourth Avenue SE and Magnolia Road

The data necessary for creating a standard barrier design for the Fourth Avenue SE and Magnolia Road locations was obtained from *Traffic Noise Analysis: State Route 405 (OL-1284)* as prepared by WSDOT Environmental and Special Services Northwest Region. This report presented traffic volumes and percentages of

truck and auto traffic, as well as a brief description of the Fourth Avenue SE and Magnolia Road projects. Both sites are located on SR-405 in King Co. and in South Snohomish Co. Because high-occupancy vehicle (HOV) lanes are being added to SR-405, WSDOT selected these two sites for possible special noise barrier applications.

Fourth Avenue SE is located in Segment B of the SR-405 project, which extends from SR-527 to Danvers Road. This segment is primarily designated as residential, with some commercial activity at interchanges. Sixteen first-row single-family receivers on Fourth Avenue SE border the SR-405 right-of-way, and 11 second-row residences are located across Fourth Avenue.

The Magnolia Road site is located in Segment C of the SR-405 project, which lies between Danvers Road and I-5. The Magnolia Road site is on the west side of SR-405 between 196th Street SW and I-5. This is primarily a residential area, consisting of single-family homes.

For the receivers at the Fourth Avenue SE site, existing L_{eq} levels range from 65 to 67 dBA for first-row receivers and from 59 to 63 dBA for second-row receivers. Current L_{eq} values at the Magnolia Road site are 64 to 70 dBA. The addition of HOV lanes to SR-405 will cause an increase in traffic volume. The vehicle mix of the traffic for both sites (96% autos, 2% medium trucks, and 2% heavy trucks) and traffic speed (55 miles per hour) were obtained from *OL-1284*. Alpha and shielding factors for the Fourth Avenue and Magnolia Road sites were 0.5 and 0.0, respectively. Site maps depicting roadway, barrier, and receiver locations for Fourth Avenue and Magnolia Road are located on page A-1 and A-2.

Fourth Avenue barrier heights were established by using the LOS program. WSDOT recommended a 12-foot tall barrier for Fourth Avenue SE along the shoulder of SR-405. However, because the line-of-sights ranged from 12 to 14 feet and an insertion loss of at least 10 dBA was desired, Louisville recommended 18-foot tall barrier segments where the line-of-sight fell below 12 feet. For the remaining barrier segments, a 20-foot tall barrier was recommended. The line-of-site breaks are displayed in Table VII on page B-9.

Because Louisville's standard barrier design deviates from WSDOT's design as a result of line-of-sight restrictions, the two designs differ in both acoustical performance and cost. Report *OL-1284* predicted that the WSDOT barrier design will provide insertion losses of 7 to 11 dBA at a cost of approximately \$360,000. The modified Louisville design predicted insertion losses of 10 to 12 dBA for the front-line receivers at a cost of \$538,700 for 35,911 square feet of concrete barrier. Table VIII on page B-10 presents a comparison of the barriers proposed by Louisville and WSDOT.

Magnolia Road barrier heights were established by calculating line-of-sights, which ranged from 0 to 10 feet. Line-of-site breaks for Magnolia are shown in Table IX on page B-11. WSDOT recommended a 14-foot tall barrier for Magnolia Road. Unlike WSDOT's 14-foot barrier design, Louisville designed a barrier that was 20 feet tall to achieve an approximate insertion loss of 10 dBA.

The two standard barrier designs developed by WSDOT and Louisville were compared. The WSDOT barrier design produced insertion losses of 6 to 10 dBA. An

increased insertion loss of 8 to 11 dBA for front-line receivers was achieved by Louisville's 20-foot barrier design at a cost of \$361,700 for 24,114 square feet of concrete barrier.

Kent Commons Play Field

The Kent Commons Play Field project involves widening SR-167 and adding HOV lanes along residential, commercial, and undeveloped property. This project is bordered on the north and west by SR-167. Future noise levels for the nearest receivers at Kent Commons are expected to range from 69 to 71 dBA.

The data needed to create a standard barrier design for Kent Commons were obtained from WSDOT *Noise Report XLO647*, which contained truck and auto percentages and speeds. To determine traffic volumes, WSDOT used a 2+HOV definition ("acceptable level of service", page 3) in its noise report, whereas Louisville used 1400 pcphpl (passenger cars per hour per lane) and 1000 pcphpHOV1 (passenger cars per hour per High Occupancy Vehicle lane). This judgment was made assuming "acceptable level of service" (Level of Service=C). The volumes were obtained from page 7-33 of the Highway Capacity Manual. Besides traffic volumes, alpha and shielding factors of 0.5 and 0.0, respectively, were used to model the Kent Commons site. Kent Commons Play Field's site map is presented on page A-3.

As in the two previous projects, line-of-sights were calculated to establish barrier heights. Most of the line-of-sights for Kent Commons ranged from 0 to 4 feet. *Noise Report XLO647* advised using a 10-foot barrier along the shoulder of SR-167 at

Kent Commons Play Field. Louisville's barrier design used a 19-foot barrier that would provide adequate line-of-sight breaks for special barrier applications, while producing at least a 9 dBA insertion loss. The line-of-sight breaks for Kent Commons are located in Table XI on page B-13.

The 19-foot tall barrier designed by Louisville provided an insertion loss of approximately 8 to 11 dBA, whereas the 10-foot barrier designed by WSDOT produced an insertion loss of 7 to 9 dBA. A comparison of the noise analysis results of the two designs is presented in Table XII on page B-14. The size of the Kent Commons Play Field noise barrier design was 50,838 square feet, and it would cost \$711,700 as modeled.

Spokane Project

WSDOT supplied Louisville with aerial photographs, peak-hour traffic data, and preliminary cross-sections for the planned North Spokane Freeway (NSF) route. A draft noise report, a City of Spokane Map, an EIS map, and a preliminary NSF map of all options were also provided. These reports contained information on the Spokane Community College Area, which was used by Louisville for analytical and modeling considerations.

The NSF project is located in the eastern quadrant of the city of Spokane. The project consists of a collector/distributor system adjacent to I-90 and a new freeway from I-90 northward to U.S. 395 in Spokane County. The NSF project includes two alternative routes: the Market/Greene Alternative and the Havana Alternative. If the

Market/Greene alternative is selected, noise levels in the Spokane Community College area will increase significantly. Therefore, the Spokane Community College Area was selected as a possible site for implementation of special noise barrier applications.

Spokane Community College Area

The Spokane Community College Area consists of the actual college campus and a residential neighborhood across the NSF. The proposed Market/Greene Alternative would be adjacent to the college and the neighborhood. Portions of this alternative would be elevated above an existing parking facility at the Spokane Community College Campus. The WSDOT *Summary of Noise Analysis Results* predicts noise levels exceeding the 67 dBA noise abatement criteria for schools and residences (exterior) as stated in 23CFR772, August 1993.

Traffic volumes were determined by using the transportation modeling results from TMODEL2 (TM2), which consisted of traffic modeling plots for the Market/Green alternative. These plots presented projected traffic volumes for the year 2020 at pm peak hour, for both north and southbound directions. In addition, a telephone conversation with WSDOT personnel provided data on the vehicle mix of traffic (87% autos, 8% medium trucks, and 5% heavy trucks) and the vehicle speed (60 mph) to be assumed for modeling purposes. Alpha and shielding factors were 0.0 and 0.0, respectively. A site map depicting the location of roadway, barrier, and receiver elements is located on page A-4.

In addition to the input parameters, 14 receivers were modeled on the south side of Market/Greene to represent the neighborhood across from the Spokane Community College. These receivers were located near first-row and second-row houses of the residential area. Line-of-sights for the 14 residential receivers were approximately 4 to 6 feet.

To represent the Spokane Community College Campus, receivers were located near first-row and second-row buildings. Because several of these buildings have second and third stories, six receivers were modeled 25 feet above the ground to represent these buildings. Line-of-sights located at ground level were approximately 4 to 9 feet, whereas line-of-sights for the elevated, second-story receivers were approximately 9 to 14 feet. The line-of-sight breaks are shown in Table XIII on page B-15.

A 10-foot barrier design was recommended by WSDOT. In contrast, Louisville used a 20-foot barrier design for both the north and south corridors of the project to achieve a significantly higher insertion loss (10 dBA) than that provided by the WSDOT barrier design. The 10-foot barrier designed by WSDOT resulted in 67 dBA L_{eq} contours approximately 800 feet from the centerline. Louisville's modeling could not produce a 67 dBA L_{eq} contour because the 20-foot barrier design lowered L_{eq} values below 67 dBA. For the receivers modeled, no-barrier L_{eq} values were approximately 69 dBA, and 20-foot barrier L_{eq} values were 59 dBA. Thus, an insertion loss of approximately 10 dBA was achieved by the 20-foot barrier design. Table XIV on page B-16 displays L_{eq} values for the 40 receivers modeled. The 20-

foot barrier design contained 144,506 square feet at a cost of \$2.2 million assuming a cost of \$15/square foot for construction and materials.

After the standard barrier design was created and the acoustical results were compared, REBAR was used to determine the amount of insertion loss degradation associated with Spokane's parallel barrier design. REBAR calculations determined insertion loss degradation associated with reflective and absorptive barriers.

First, REBAR was used to calculate insertion loss degradation associated with 24-foot reflective barriers ($NRC = 0.0$) in comparison to a single barrier 24 feet tall. For the neighborhood located across from Spokane Community College, the insertion loss degradation resulting from reflective parallel barriers ranged from 1.3 to 2.7 dBA, resulting in an insertion loss of approximately 8 dBA. The insertion loss for the Spokane Community College side of the project was decreased by 2.3 to 5.6 dBA, producing an insertion loss of approximately 8 dBA.

Applying absorptive material to parallel barriers can significantly decrease the amount of insertion loss degradation. Since Durisol is the recommended absorptive treatment, the REBAR analysis incorporated a noise reduction coefficient of 0.75 for the entire height of both barriers. In order to achieve an insertion loss (8 dBA) similar to a 24-foot tall reflective parallel barrier design, absorptive material was applied to parallel barriers 18-feet in height, resulting in a slight (1 dBA) increase in insertion loss. Table II on page B-2 displays the modeled receivers' insertion loss for both reflective and absorptive parallel barriers.

MODIFICATIONS TO STANDARD BARRIER DESIGN

Methodology for determining the selection of a special noise barrier application for each project site consisted of assessing the characteristics of each site and considering the acoustic, aesthetic, and economic impacts associated with special noise barriers. Therefore, special noise barriers which demonstrate the greatest potential for minimizing acoustic, aesthetic, and economic impacts for a particular site are given the most consideration. Each project site has characteristics which may warrant the use of a particular special noise barrier. Some characteristics which influence the special noise barrier selection include impacted receivers, the existing noise levels, line-of-sight breaks, and the height and attenuation provided by the base-line barrier design.

Because impacted receivers influence special noise barrier selection, providing optimal attenuation for an increased number of sensitive receivers is important. Also, existing site noise levels influence selection because receivers that are exposed to a larger increase in noise levels require more attenuation. The line-of-sight breaks will provide restrictions for the application of special barriers. Because special barriers require that a 2-foot line-of-sight break be maintained, the increased acoustical performance provided by some special barriers allows for a reduction of barrier heights. The reduction of barrier heights could reduce adverse aesthetic and economic impacts associated with noise barrier construction.

Because consistent criteria is needed for applying special noise barriers, the following step-by-step procedure was used for the sites investigated in this report and could standardize the special barrier design process.

- Step 1: Establish a conventional barrier design for a project.
- Step 2: Calculate line-of-sight breaks on the conventional barrier design.
- Step 3: Lower conventional barrier heights based on the 2-foot line-of-sight restriction and calculate resulting insertion losses.
- Step 4: Apply added insertion losses of the special barriers presented as acoustical "rules of thumb" from this report.
- Step 5: Calculate costs of all barriers.
- Step 6: Identify additional maintenance costs and determine aesthetic impacts.
- Step 7: Select final barrier design.

An illustration of how these steps were applied to the projects of this report is as follows.

Step 1.

The standard conventional barrier designs for the four sites are presented in the previous section of this report.

Step 2.

Because the LOS program calculates when the line-of-sight is above the top of the barrier, all barrier heights in the data files were lowered to zero to determine the location where the line-of-sight hits on the barrier. For these projects, the LOS breaks

were calculated by subtracting the line-of-sight from the established conventional barrier height and are presented in Tables VII, IX, XI, and XIII.

Step 3. & Step 4.

Based on the 2-foot line-of-sight restriction, conventional barrier designs were lowered and OPTIMA was executed to determine new values for insertion loss. The acoustic "rules of thumb" were applied to the resulting design's insertion loss. Barrier heights and insertion losses are presented in Tables XV-XVIII on pages B-18-B-21.

Step 5.

Costs of conventional barriers were provided by WSDOT, and were \$15 per square foot for the Fourth, Magnolia, and Spokane sites and \$14 per square foot for the Kent site. Special noise barrier costs were determined using the cost estimates provided by Highway Structures, Inc. and Bornstein Building Company. The cost factors presented earlier in this report were directly applied to each barrier design. Final costs are given in Tables XV-XVIII on pages B-18-B-21. An example detailing the cost calculations for a conventional and absorptive T-top barrier is presented on the next page.

Example Cost Calculations (Fourth Avenue)

Conventional Barrier (18' & 20' Barrier Sections)

Square Feet of Barrier Material * Unit Cost

$$35911 \text{ sqft.} * \$15/\text{sqft.} = \underline{\$538,700}$$

Absorptive T-top Barrier (13' & 15' Barrier Sections)

(Square Feet of Barrier Material * Conventional Barrier Unit Cost * Cost Factor) + (Unit Cost of Absorptive Material * 3 Foot Absorptive Strip * Linear Feet of Barrier)

Highway Structures Inc.

$$(26487 \text{ sqft.} * \$15/\text{sqft.} * 1.182) + (\$7/\text{sqft.} * 3 \text{ ft.} * 1882 \text{ L.F.}) \\ = \underline{\$509,100}$$

Bornstein Building Co.

$$(26487 \text{ sqft.} * \$15/\text{sqft.} * 1.41) + (\$7/\text{sqft.} * 3 \text{ ft.} * 1882 \text{ L.F.}) \\ = \underline{\$599,700}$$

Final Cost (Average of 2 Estimates)

$$(\$509,100 + \$599,700) / 2 = \$554,400$$

Because barrier material and labor costs can be different in various areas of the state, WSDOT barrier designers should inquire about price ranges from local contractors and material suppliers to obtain a more accurate cost analysis of the special barriers. Although concrete was the material of choice in this report, designers could investigate using materials less expensive than concrete in their highway noise barrier programs.

Step 6.

After the initial cost of each barrier is determined, any additional maintenance costs resulting in those barriers should be identified. The economics section of this report includes possible maintenance increases associated with special noise barrier applications. In addition to maintenance considerations, attention should be given to whether aesthetics are improved by the application of one of these special barriers. Tables XV-XVIII on pages B-18-B-21 give a checklist to illustrate maintenance and aesthetic considerations.

Step 7.

The selection of the final barrier should incorporate the ideas presented in the previous six steps. However, goals of this report include the hope that a few of these designs will be applied to actual highway projects in Washington State as field laboratories. Therefore, Louisville's selection recommendations are presented below.

Fourth Avenue

The Fourth Avenue site consisted of 16 front-line receivers and 11 second-line receivers with existing L_{eq} levels of 65-67 dBA and 59-63 dBA for first and second row receivers, respectively. Eleven and 13-foot line-of-sight resulted in a standard barrier design of 18-foot (BFA-BFI) and 20-foot (BFJ-BFS) barrier sections to achieve an insertion loss of at least 10 dBA for front-line receivers.

A 3 foot shorter single-wall absorptive barrier would be the least expensive special barrier to construct (\$493,400), while still providing a 10 dBA insertion loss. The cost of an equally performing conventional barrier would be \$45,000 greater than the shorter single-wall absorptive barrier. Also, reducing barrier height by 3 feet would lessen aesthetic impacts.

Magnolia Road

The Magnolia Road Project Area is located along SR-405. This is a residential area with L_{eq} values ranging from 64 to 70 dBA. Improvements to SR-405 are expected to increase traffic volumes, creating future noise levels ranging from 66 to 75 dBA. Therefore, investigation into possible noise mitigation procedures were performed.

The Magnolia Road site offers an opportunity to study absorptive T-tops. After reducing the 20-foot barrier sections to 13 feet, an absorptive T-top barrier would provide the same acoustic performance (10 dBA insertion loss) as a conventional barrier 7 feet taller, while costing \$30,000 less. The 7 foot reduction in height would significantly improve aesthetics and would create greater acceptability among property owners.

Kent Commons Play Field

A 19-foot standard barrier design would offer at least a 9 dBA insertion loss to Kent Commons Play Field receivers. An increased insertion loss of 10 dBA would be achieved by a shorter, 16-foot Y-top barrier. Reducing barrier heights by 3 feet would improve the aesthetic quality of the surrounding environment. A 16-foot Y-top barrier would cost approximately \$130,000 more than a conventional barrier 19 feet high; however, the Y-top barrier would reduce aesthetic impacts by the 3 foot reduction in height.

Spokane Community College Area

The Spokane Community College Area is an elevated section of the Market/Greene alternative of the North Spokane Freeway with impacted receivers located on the east (neighborhood) and west (Spokane Community College) sides of the freeway. Line-of-sight breaks for the neighborhood and Spokane Community College were approximately 11 to 16 feet. A 20-foot barrier design was recommended to obtain an insertion loss of at least 10 dBA.

Three barrier designs were analyzed, one involved the investigation of a barrier design for the neighborhood, another investigated a barrier design for the Spokane Community College, and the third design consisted of parallel barriers for both sides of the Market/Greene alternative.

The 20-foot standard barrier design for the neighborhood was lowered to 16 feet to apply an equally performing (10 dBA insertion loss) single wall absorptive barrier. Since the Market/Greene alternative is an elevated section of freeway, the 4-foot reduction in height would offer the neighborhood a less obstructive view. In addition, the cost of the single-wall absorptive barrier (\$864,900) is less than the absorptive T-top, Y-top and slanted-top barriers of equal acoustical performance (\$907,000, \$1,294,400, and \$1,333,500). The single-wall absorptive barrier would cost \$130,000 less than a 20-foot tall conventional barrier.

Spokane Community College's 20-foot standard barrier design was also lowered to apply special noise barriers of the same acoustic performance (10 dBA insertion loss). Because of barrier height reduction, all four special barrier types would enhance the surrounding environment; however, an absorptive T-top would provide the best aesthetic improvement because this barrier allows for the greatest reduction in height (7 feet). An absorptive T-top barrier would also cost less than a Y-top or slanted top barrier of equal acoustic performance (\$457,200 and \$503,300 less), and would be less expensive (\$102,800) than constructing a 20-foot high conventional barrier.

Because the Spokane Community College Area has receivers located on both sides of the Market/Greene alternative, a parallel barrier design would need to be constructed to accommodate for both sets of receivers. Past research has determined that the application of absorptive material to parallel barriers is beneficial in reducing insertion loss degradation due to multiple reflections. REBAR was used to investigate the degradation in insertion loss for a 24-foot reflective (NRC=0.0) and an 18-foot

absorptive (NRC=0.75) parallel barrier design. A 24-foot reflective parallel barrier would produce an 8 dBA insertion loss, while the application of absorptive material to 18-foot high barrier sections would improve the insertion loss to approximately 9 dBA for some of the receivers modeled. In addition to the slight improvement in insertion loss, reducing barrier sections by 6 feet would significantly improve the aesthetic quality of the surrounding environment. Table II on page B-2 displays insertion losses for the reflective and absorptive parallel barrier designs. Although the 18-foot absorptive parallel barrier design would increase costs by \$260,300, receivers on both sides of the freeway would benefit by providing an insertion loss similar to a 24-foot tall reflective design.

CONCLUSIONS AND RECOMMENDATIONS

Each modeled WSDOT highway project could benefit from the construction of a special noise barrier. The five special noise barriers under consideration show excellent promise as viable alternatives to constructing taller conventional barriers. As discussed earlier, special noise barriers provide increased acoustical performance over conventional barriers of the same height. Thus special noise barriers could improve the aesthetics of the highway environment; and costs could be lowered because less material is needed for construction, and foundation requirements are reduced. Because the acoustic, aesthetic, and economic impacts vary with each application, an analysis of each of these impacts on a particular site should be part of the process of selecting a particular type of barrier. Recommendations for the sites investigated are presented below.

Fourth Avenue S. E.:	Single-wall absorptive
Magnolia Road:	Absorptive T-top
Kent Commons Play Field:	Y-top
Spokane Community College Area:	Single-wall absorptive (Neighborhood) Absorptive T-top (SCC) Absorptive parallel (Both sides)

Proposed Phase III research includes the construction of scale models representing the four projects presented in this report. Scale modeling would verify the use of the acoustic "rules of thumb" in this study and the mathematical formulation presented in the previous Phase I report before the implementation of special noise barriers in Washington State.

It is hoped that one or more of the recommendations provided will be used in actual field studies in Washington State. This would provide data that could encourage the expanded use of special barrier applications across the state. With the proper site selection, the true effectiveness of these special noise barrier applications could be verified.

REFERENCES

- [AASHTO 1984] American Association of State Highway and Transportation Officials. Guide on Evaluation and Attenuation of Traffic Noise, AASHTO, 1984. pp. 26-32.
- [Bowlby 1983] Bowlby, W. and Cohn, L. F., "Prediction of Highway Construction Noise Levels," *Journal of Construction Engineering and Management*, Vol. 109, No. 2, 1983. pp. 163-180.
- [Bowlby 1987] Bowlby, W., L. F. Cohn, and R. A., Harris, "A Review of Studies of Insertion Loss Degradation for Parallel Highway Noise Barriers," *Noise Control Engineering Journal*, Vol. 28, No. 2, 1987. pp. 40-53.
- [Bowlby 1992] Bowlby, W., "In Service Experience with Traffic Noise Barriers," National Cooperative Highway Research Program Synthesis of Highway Practice 181, Transportation Research Board, Washington D.C., 1992. pp. 17-32.
- [Cohn 1981] Cohn, L. F. "Highway Noise Barriers," National Cooperative Highway Research Program Synthesis of Highway Practice 87, Transportation Research Board, Washington D.C., 1981. pp. 30-51.
- [Cohn 1984] Cohn, L. F and Bowlby, W., "Minimizing Highway Noise Barrier Intrusion," *Journal of Environmental Engineering*, Vol. 110, No. 3, 1983. pp. 534-549.
- [Cohn 1993] Cohn, L. F. and Harris, R. A., Special Noise Barrier Applications, 1993. pp. 1-99.
- [FHWA 1982] Federal Highway Administration. Report of Field Review-Highway Traffic Noise Impact Identification and Mitigation Decision Making Processes, Washington, D.C.: U. S. Department of Transportation, FHWA, 1982 pp. 13-14.
- [Hajek 1984] Hajek, J. J. and C. Blaney, "Evaluation of T-Profile Highway Noise Barriers," *Transportation Research Record 983*, 1984. pp. 8-17.

- [Harris 1982] Harris, R. A., "Determination of Effectiveness of Noise Barriers Along I-285, Atlanta," *Transportation Research Record 865*, 1982. pp. 1-4.
- [Harris 1984] Harris, R. A., "Determination of Reference Energy Mean Emission Level in Georgia," *Transportation Research Record 983*, 1984. pp. 22-26.
- [Hayek 1990] Hayek, S. I., "Mathematical Modeling of Absorptent Highway Noise Barriers," *Applied Acoustics*, Vol. 31, 1990. pp. 77-100.
- [Hurd 1987] Hurd, M. K., " Screening and Barrier Walls: Miles of Markets for Concrete," *Concrete Construction*, 1987. pp. 477-488.
- [Kim 1992] Kim, Jae-Seok, Performance of Absorptive Treatments for Single Highway Noise Barriers, Dissertation, The University of Kentucky, 1992. pp. 208.
- [May 1980-1] May, D. N. and M. M. Osman, "Highway Noise Barriers: New Shapes," *Journal of Sound and Vibration*, Vol. 71, No. 1, 1980. pp. 73-101.
- [McShane 1990] McShane, W. R. and R. P. Roess, Traffic Engineering, Prentice Hall, Inc., Englewood Cliffs, New Jersey, 1990. pp. 217-218.
- [Nicolas 1989] Nicolas, J., A. L'Esperance, and G. A. Daigle, "Insertion Loss of Absorptent Barriers on Ground," *Journal of the Acoustical Society of America*, Vol.86, 1989. pp. 1060-1064.
- [Simpson 1976] Simpson, M. A., Noise Barrier Design Handbook, FHWA-RD-76-58, U. S. Department of Transportation, Washington D.C. 1976. pp. 3-52.

APPENDIX A SITE MAPS

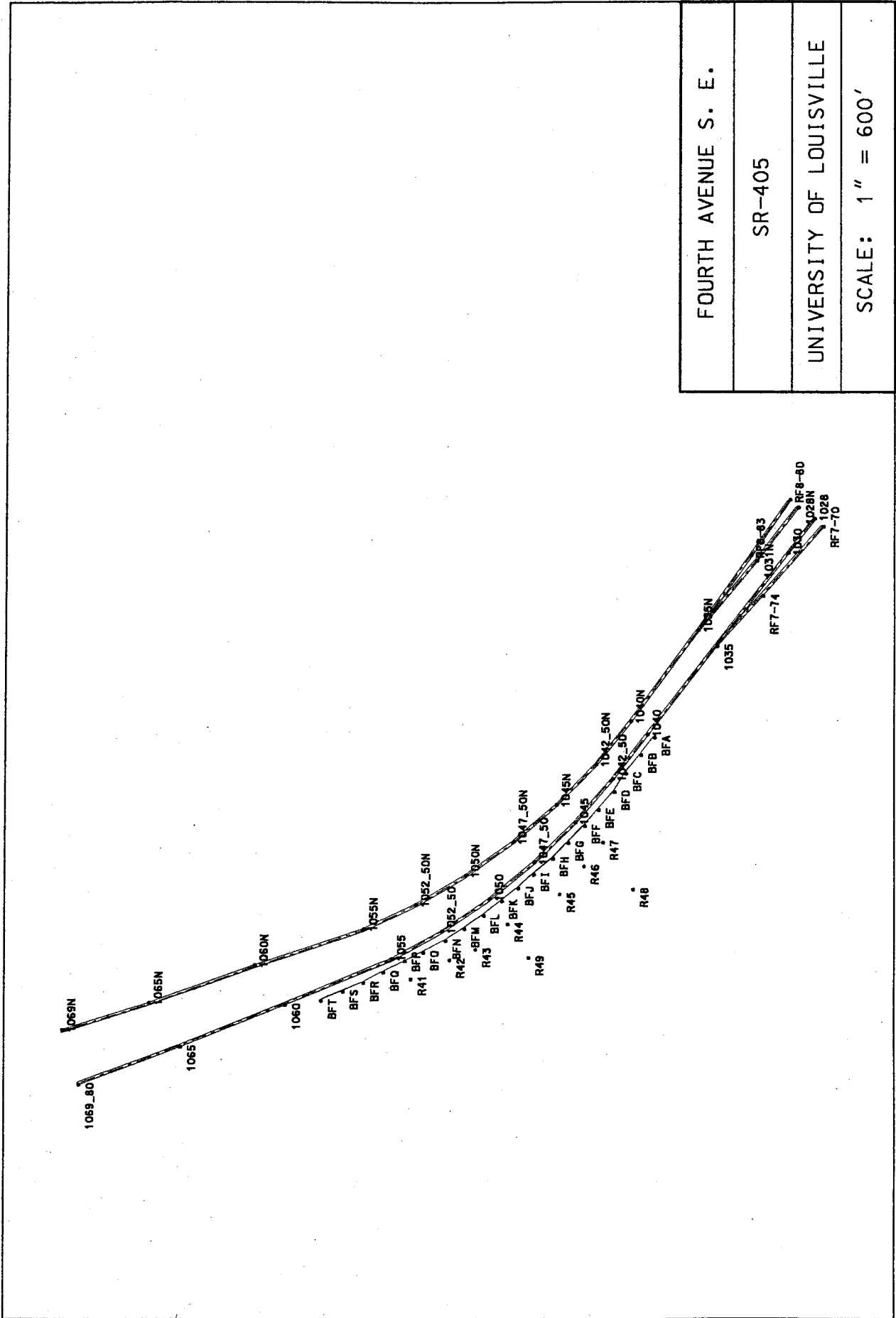

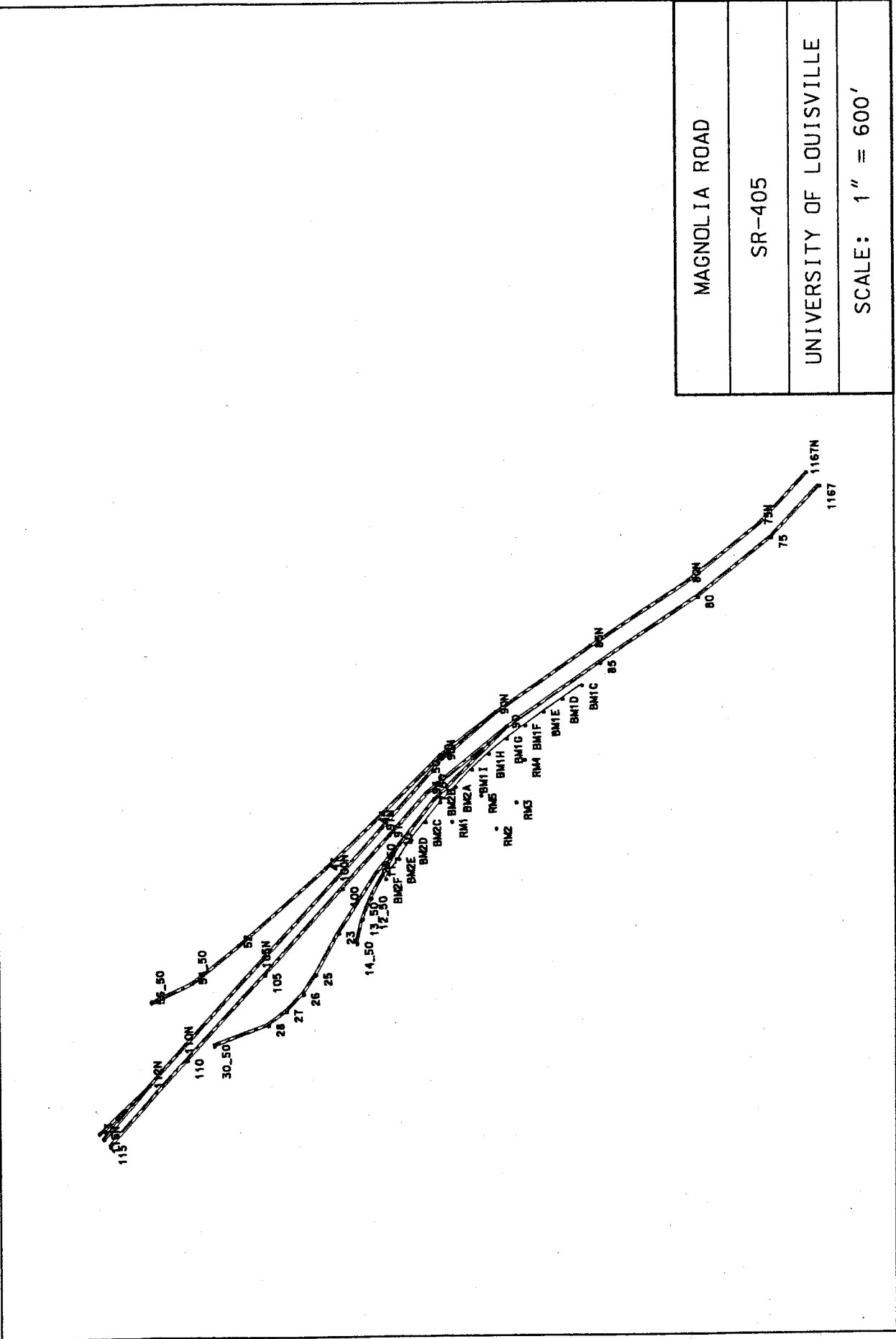

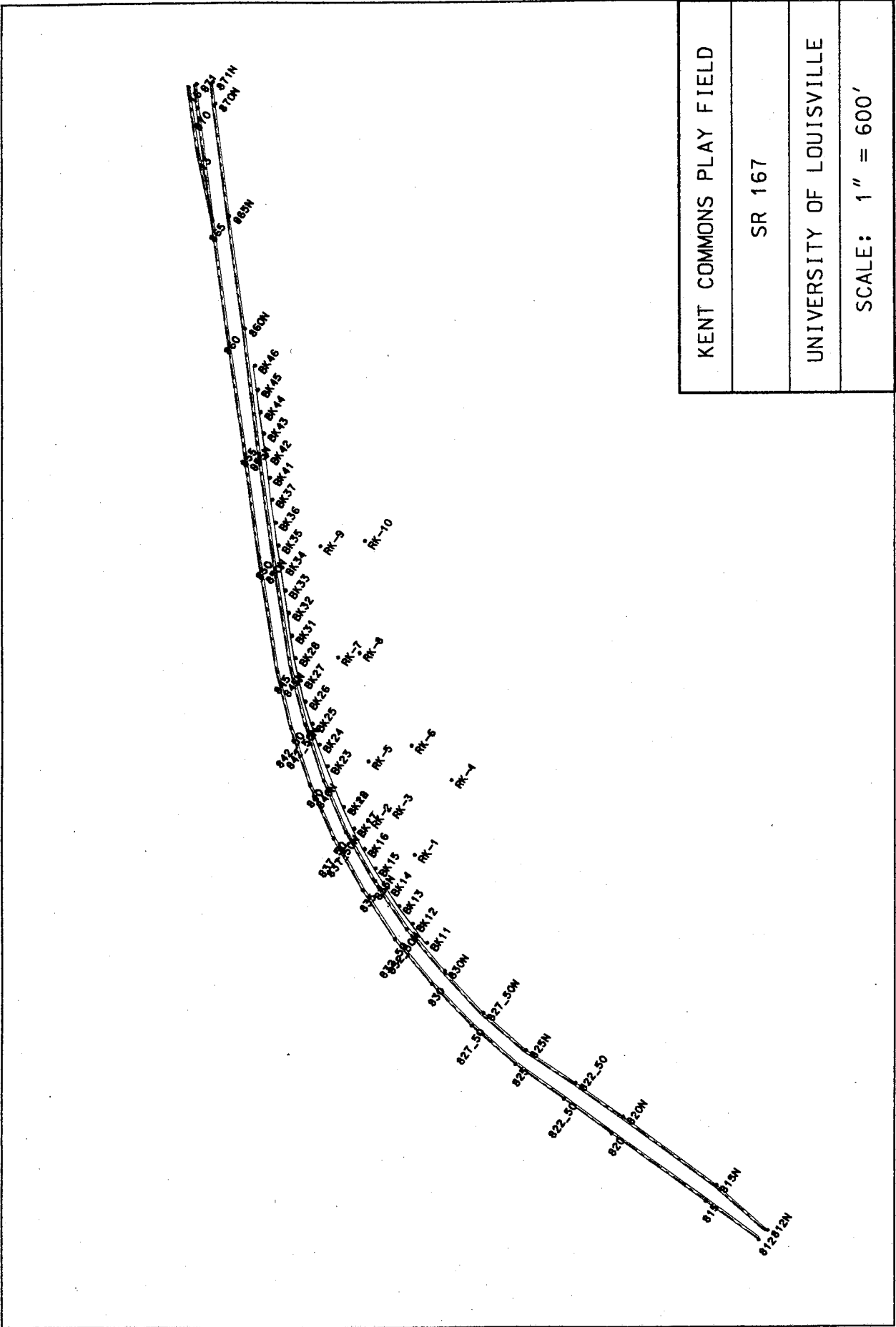

KENT COMMONS PLAY FIELD
SR 167
UNIVERSITY OF LOUISVILLE
SCALE: 1" = 600'

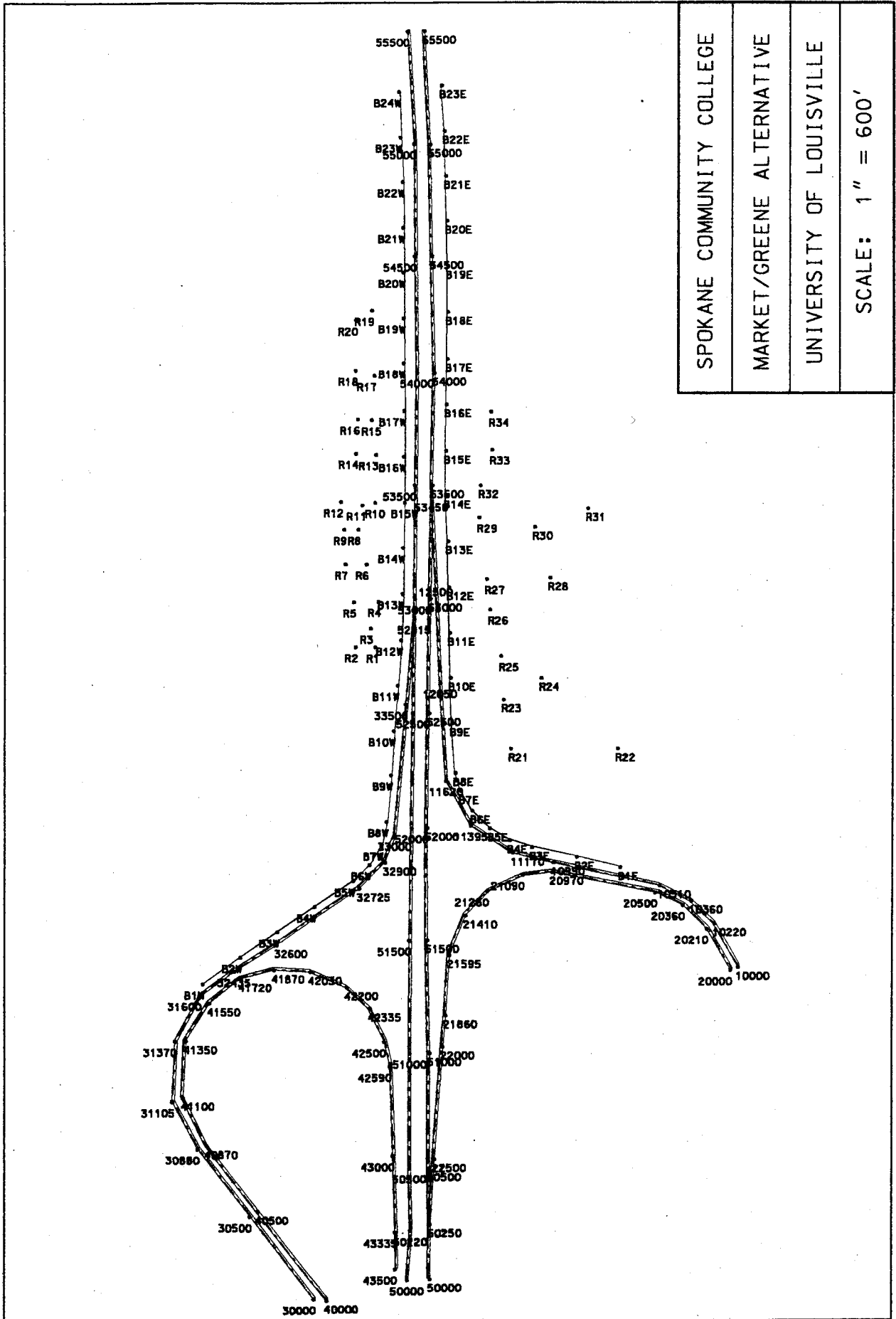

APPENDIX B TABLES

TABLE I
OPTIMA RESULTS FOR SLANTED-TOP MODELING

Receiver Name	Insertion Loss (dBA)	
	Barrier 50 feet from road	Barrier 45 feet from road
1	7.6	7.4
2	5.8	5.9
3	5.1	5.2

TABLE II
SPOKANE COMMUNITY COLLEGE AREA
INSERTION LOSS COMPARISON BETWEEN
SINGLE BARRIER AND REFLECTIVE AND ABSORPTIVE
PARALLEL BARRIERS

U of L Receiver Name	Insertion Loss (dBA)		
	24' Single Barrier	24' Reflective Parallel Barriers NRC = 0.0	18' Absorptive Parallel Barriers NRC = 0.75
R1	9.1	7.4	7.9
R2	10.0	7.7	8.2
R3	9.8	7.9	8.4
R4	9.0	7.3	7.8
R5	10.4	8.1	8.4
R6	10.4	8.4	8.8
R7	10.7	8.1	8.5
R8	10.9	8.7	8.8
R9	11.0	8.3	8.7
R10	10.2	8.4	8.8
R11	10.8	8.7	8.9
R12	11.2	8.5	8.8
R13	10.1	8.8	8.7
R14	11.2	9.0	9.0
R15	10.5	8.6	8.9
R16	11.0	8.9	8.9
R17	9.9	8.1	8.5
R18	10.9	8.7	8.8
R19	9.6	7.7	8.2
R20	10.5	8.3	8.7
R21	10.7	7.4	8.3

U of L Receiver Name	Insertion Loss (dBA)		
	24' Single Barrier	24' Reflective Parallel Barriers NRC = 0.0	18' Absorptive Parallel Barriers NRC = 0.75
R22	8.3	2.7	5.8
R23	10.8	7.8	8.3
E23	11.6	7.3	8.0
R24	10.7	6.7	8.0
R25	10.8	7.9	8.3
E25	11.7	7.7	8.1
R26	10.7	8.1	8.5
E26	12.0	8.5	8.7
R27	10.7	8.1	8.5
E27	12.2	8.8	8.9
R28	11.1	7.1	8.2
R29	10.4	8.1	8.7
E29	12.6	9.8	9.5
R30	11.0	7.3	8.1
R31	11.2	6.6	8.2
R32	10.6	8.3	8.8
R33	11.1	8.7	9.0
E33	12.5	9.2	9.4
R34	11.1	8.7	9.1

TABLE III
FOURTH AVENUE
COMPARISON OF NOISE ANALYSIS RESULTS
1975 FHWA VERSUS 1993 WASHINGTON STATE
REFERENCE MEAN EMISSION LEVELS

U of L Receiver Name	L _{eq} (dBA) No Barrier		L _{eq} (dBA) Barrier		Insertion Loss (dBA)	
	1975 FHWA	1993 Washington State	1975 FHWA	1993 Washington State	1975 FHWA	1993 Washington State
R41	72.9	73.0	63.2	63.1	9.7	10.0
R42	72.5	72.5	60.9	60.7	11.6	11.9
R43	71.6	71.7	62.3	62.0	9.3	9.6
R44	70.8	70.5	58.9	58.7	11.9	11.8
R45	69.6	69.4	59.6	59.3	10.0	10.1
R46	70.2	70.1	60.2	60.0	10.0	10.1
R47	70.5	70.4	60.3	60.1	10.3	10.2
R48	65.4	65.5	58.7	58.5	6.7	7.0
R49	66.8	66.9	59.6	59.4	7.2	7.6

**TABLE IV
MAGNOLIA ROAD
COMPARISON OF NOISE ANALYSIS RESULTS
1975 FHWA VERSUS 1993 WASHINGTON STATE
REFERENCE MEAN EMISSION LEVELS**

U of L Receiver Name	L _{eq} (dBA) No Barrier		L _{eq} (dBA) Barrier		Insertion Loss (dBA)	
	1975 FHWA	1993 Washington State	1975 FHWA	1993 Washington State	1975 FHWA	1993 Washington State
RM1	71.7	71.5	61.1	61.0	10.5	10.5
RM2	67.4	67.6	61.1	60.9	6.4	6.7
RM3	67.9	68.1	61.3	61.1	6.7	7.0
RM4	68.4	67.9	60.1	60.0	8.3	7.9
RM5	71.4	71.3	61.0	60.9	10.3	10.4

TABLE V
KENT COMMONS PLAY FIELD
COMPARISON OF NOISE ANALYSIS RESULTS
1975 FHWA VERSUS 1993 WASHINGTON STATE
REFERENCE MEAN EMISSION LEVELS

U of L Receiver Name	L _{eq} (dBA) No Barrier		L _{eq} (dBA) Barrier		Insertion Loss (dBA)	
	1975 FHWA	1993 Washington State	1975 FHWA	1993 Washington State	1975 FHWA	1993 Washington State
RK-1	69.7	68.7	61.9	61.3	7.8	7.4
RK-2	69.1	67.8	60.8	60.1	8.3	7.7
RK-3	69.4	68.2	60.1	59.4	9.4	8.9
RK-4	65.2	64.5	59.0	58.3	6.2	6.2
RK-5	69.2	68.1	59.1	58.4	10.1	9.7
RK-6	66.4	65.7	58.4	57.6	8.0	8.0
RK-7	68.6	67.4	58.1	57.3	10.6	10.1
RK-8	67.4	66.4	57.6	56.8	9.8	9.6
RK-9	68.4	67.1	58.3	57.6	10.0	9.5
RK-10	65.9	65.1	57.6	56.8	8.3	8.3

TABLE VI
SPOKANE COMMUNITY COLLEGE AREA
COMPARISON OF NOISE ANALYSIS RESULTS
1975 FHWA VERSUS 1993 WASHINGTON STATE
REFERENCE MEAN EMISSION LEVELS

U of L Receiver Name	L _{eq} (dBA) No Barrier		L _{eq} (dBA) Barrier		Insertion Loss (dBA)	
	U of L	WSDOT	U of L	WSDOT	U of L	WSDOT
R1	67.9	66.5	59.3	58.2	8.6	8.4
R2	68.6	67.3	59.5	58.3	9.2	9.0
R3	68.5	67.1	59.3	58.1	9.2	9.0
R4	68.0	66.7	59.5	58.4	8.5	8.2
R5	68.8	67.5	59.3	58.1	9.4	9.3
R6	69.0	67.7	59.4	58.3	9.6	9.4
R7	69.0	67.7	59.3	58.1	9.7	9.6
R8	69.3	68.0	59.4	58.3	9.9	9.7
R9	69.2	68.0	59.3	58.1	9.9	9.8
R10	69.2	67.9	59.6	58.6	9.6	9.3
R11	69.3	68.0	59.4	58.3	9.9	9.7
R12	69.3	68.0	59.2	58.1	10.0	9.9
R13	69.3	68.0	59.8	58.8	9.5	9.2
R14	69.5	68.3	59.4	58.3	10.1	10.0
R15	69.3	68.1	59.6	58.5	9.8	9.5
R16	69.4	68.1	59.3	58.2	10.0	9.9
R17	68.9	67.7	59.6	58.6	9.3	9.0
R18	69.2	68.0	59.3	58.2	9.9	9.8
R19	68.3	67.0	59.3	58.3	9.0	8.7
R20	68.8	67.5	59.2	58.1	9.6	9.4
R21	69.5	68.1	59.9	58.7	9.6	9.4
R22	67.4	65.9	60.0	58.6	7.4	7.3
R23	69.5	68.2	59.9	58.7	9.6	9.5

U of L Receiver Name	L _{eq} (dBA) No Barrier		L _{eq} (dBA) Barrier		Insertion Loss (dBA)	
	U of L	WSDOT	U of L	WSDOT	U of L	WSDOT
E23	73.5	72.2	63.8	62.5	9.7	9.7
R24	69.1	67.7	59.6	58.4	9.4	9.3
R25	69.3	67.9	59.7	58.5	9.6	9.5
E25	73.2	71.8	63.3	62.1	9.9	9.7
R26	69.1	67.8	59.5	58.4	9.6	9.4
E26	73.6	72.1	63.2	62.0	10.3	10.1
R27	69.2	67.9	59.5	58.4	9.7	9.5
E27	73.8	72.3	63.2	62.0	10.5	10.3
R28	68.7	67.4	59.0	57.8	9.7	9.6
R29	69.2	67.9	59.6	58.5	9.6	9.3
E29	74.2	72.8	63.2	62.1	11.0	10.8
R30	68.8	67.5	59.1	57.9	9.6	9.6
R31	68.0	66.6	58.2	56.9	9.8	9.7
R32	69.5	68.1	59.7	58.6	9.8	9.5
R33	69.8	68.5	59.7	58.6	10.1	9.9
E33	73.7	72.4	62.8	61.6	10.9	10.8
R34	69.8	68.5	59.6	58.5	10.2	9.9

**TABLE VII
 FOURTH AVENUE
 LINE OF SIGHT BREAKS**

Barrier Section	Barrier Height	LOS Break	Barrier Section	Barrier Height	LOS Break
BFA	18'	18.0'	BFK	20'	7.7'
BFB	18'	18.0'	BFL	20'	6.0'
BFC	18'	9.1'	BFM	20'	6.1'
BFD	18'	5.7'	BFN	20'	4.9'
BFE	18'	6.1'	BFO	20'	6.6'
BFF	18'	6.3'	BFP	20'	6.5'
BFG	18'	6.5'	BFQ	20'	6.8'
BFH	18'	6.6'	BFR	20'	7.1'
BFI	18'	5.5'	BFS	20'	6.6'
BFJ	20'	6.9'	---	---	---

Note: A positive line-of-sight break is the difference in height between the top of the barrier and the line-of-sight below the barrier top. A negative line-of-sight break is the difference in height between the top of the barrier and the line-of-sight above the barrier top.

**TABLE VIII
FOURTH AVENUE
COMPARISON OF NOISE ANALYSIS RESULTS
FOR U OF L VERSUS WSDOT**

U of L Receiver Name	WSDOT Receiver Name	L _{eq} (dBA) No Barrier		L _{eq} (dBA) Barrier		Insertion Loss (dBA)	
		U of L	WSDOT	U of L	WSDOT	U of L	WSDOT
R41	---	72.9	---	63.2	---	9.7	---
R42	B-7	72.5	73.2	60.9	63.6	11.6	9.6
R43	---	71.6	---	62.3	---	9.3	---
R44	---	70.8	---	58.9	---	11.9	---
R45	B-6	69.6	68.6	59.6	57.9	10.0	10.7
R46	---	70.2	---	60.2	---	10.0	---
R47	B-5	70.5	67.1	60.3	60.1	10.3	7.0
R48	---	65.4	---	58.7	---	6.7	---
R49	---	66.8	---	59.6	---	7.2	---

**TABLE IX
MAGNOLIA ROAD
LINE OF SIGHT BREAKS**

Barrier Section	Barrier Height	LOS Break	Barrier Section	Barrier Height	LOS Break
BM1C	20'	20.0'	BM1I	20'	8.4'
BM1D	20'	14.0'	BM2A	20'	8.9'
BM1E	20'	12.8'	BM2B	20'	9.4'
BM1F	20'	7.2'	BM2C	20'	8.9'
BM1G	20'	9.3'	BM2D	20'	10.3'
BM1H	20'	10.1'	BM2E	20'	12.6'

Note: A positive line-of-sight break is the difference in height between the top of the barrier and the line-of-sight below the barrier top. A negative line-of-sight break is the difference in height between the top of the barrier and the line-of-sight above the barrier top.

**TABLE X
MAGNOLIA ROAD
COMPARISON OF NOISE ANALYSIS RESULTS
FOR U OF L VERSUS WSDOT**

U of L Receiver Name	WSDOT Receiver Name	L _{eq} (dBA) No Barrier		L _{eq} (dBA) Barrier		Insertion Loss (dBA)	
		U of L	WSDOT	U of L	WSDOT	U of L	WSDOT
RM1	C-24	71.7	72.7	61.1	62.9	10.5	9.8
RM2	C-26	67.4	69.5	61.1	63.4	6.4	6.1
RM3	C-25	67.9	74.3	61.3	67.9	6.7	6.4
RM4	C-27	68.4	66.1	60.1	59.1	8.3	7.0
RM5	---	71.4	---	61.0	---	10.3	---

**TABLE XI
KENT COMMONS PLAY FIELD
LINE OF SIGHT BREAKS**

Barrier Section	Barrier Height	LOS Break	Barrier Section	Barrier Height	LOS Break
BK11	19'	9.8'	BK28	19'	12.4'
BK12	19'	11.2'	BK31	19'	11.8'
BK13	19'	12.4'	BK32	19'	12.1'
BK14	19'	12.4'	BK33	19'	12.5'
BK15	19'	14.2'	BK34	19'	13.0'
BK16	19'	13.0'	BK35	19'	13.4'
BK17	19'	11.2'	BK36	19'	13.6'
BK22	19'	10.9'	BK37	19'	13.7'
BK23	19'	11.0'	BK41	19'	14.1'
BK24	19'	10.3'	BK42	19'	19.0'
BK25	19'	10.9'	BK43	19'	19.0'
BK26	19'	10.8'	BK44	19'	19.0'
BK27	19'	12.3'	BK45	19'	19.0'

Note: A positive line-of-sight break is the difference in height between the top of the barrier and the line-of-sight below the barrier top. A negative line-of-sight break is the difference in height between the top of the barrier and the line-of-sight above the barrier top.

TABLE XII
KENT COMMONS PLAY FIELD
COMPARISON OF NOISE ANALYSIS RESULTS
FOR U OF L VERSUS WSDOT

U of L Receiver Name	WSDOT Receiver Name	L _{eq} (dBA) No Barrier		L _{eq} (dBA) Barrier		Insertion Loss (dBA)	
		U of L	WSDOT	U of L	WSDOT	U of L	WSDOT
RK-1	---	69.7	---	61.9	---	7.8	---
RK-2	NR	69.1	69-71	60.8	62	8.3	7-9
RK-3	NR	69.4	69-71	60.1	62	9.4	7-9
RK-4	---	65.2	---	59.0	---	6.2	---
RK-5	NR	69.2	69-71	59.1	62	10.1	7-9
RK-6	---	66.4	---	58.4	---	8.0	---
RK-7	NR	68.6	69-71	58.1	62	10.6	7-9
RK-8	---	67.4	---	57.6	---	9.8	---
RK-9	NR	68.4	69-71	58.3	62	10.0	7-9
RK-10	---	65.9	---	57.6	---	8.3	---

*NR=NEAREST RECEIVERS

**TABLE XIII
SPOKANE COMMUNITY COLLEGE AREA
LINE OF SIGHT BREAKS**

Barrier Section	Barrier Height	LOS Break	Barrier Section	Barrier Height	LOS Break
B1E	20'	20.0'	B20E	20'	20.0'
B2E	20'	-2.9'	B7W	20'	20.0'
B3E	20'	12.1'	B8W	20'	20.0'
B4E	20'	12.2'	B9W	20'	20.0'
B5E	20'	11.9'	B10W	20'	15.4'
B6E	20'	12.5'	B11W	20'	15.1'
B7E	20'	11.7'	B12W	20'	14.2'
B8E	20'	13.4'	B13W	20'	0.4'
B9E	20'	12.0'	B14W	20'	14.3'
B10E	20'	10.7'	B15W	20'	14.2'
B11E	20'	-4.0'	B16W	20'	14.3'
B12E	20'	12.4'	B17W	20'	15.5'
B13E	20'	13.1'	B18W	20'	16.4'
B14E	20'	13.4'	B19W	20'	17.1'
B15E	20'	16.7'	B20W	20'	18.2'
B16E	20'	16.5'	B21W	20'	16.0'
B17E	20'	18.0'	B22W	20'	20.0'
B18E	20'	20.0'	B23W	20'	20.0'
B19E	20'	20.0'	---	---	---

Note: A positive line-of-sight break is the difference in height between the top of the barrier and the line-of-sight below the barrier top. A negative line-of-sight break is the difference in height between the top of the barrier and the line-of-sight above the barrier top.

TABLE XIV
SPOKANE COMMUNITY COLLEGE AREA
COMPARISON OF NOISE ANALYSIS RESULTS
FOR U OF L VERSUS WSDOT

U of L Receiver Name	WSDOT Receiver Name	L _{eq} (dBA) No Barrier		L _{eq} (dBA) Barrier		Insertion Loss (dBA)	
		U of L	WSDOT	U of L	WSDOT	U of L	WSDOT
R1	---	67.9	---	59.3	---	8.6	---
R2	---	68.6	---	59.5	---	9.2	---
R3	---	68.5	---	59.3	---	9.2	---
R4	---	68.0	---	59.5	---	8.5	---
R5	---	68.8	---	59.3	---	9.4	---
R6	---	69.0	---	59.4	---	9.6	---
R7	---	69.0	---	59.3	---	9.7	---
R8	---	69.3	---	59.4	---	9.9	---
R9	---	69.2	---	59.3	---	9.9	---
R10	---	69.2	---	59.6	---	9.6	---
R11	---	69.3	---	59.4	---	9.9	---
R12	---	69.3	---	59.2	---	10.0	---
R13	---	69.3	---	59.8	---	9.5	---
R14	---	69.5	---	59.4	---	10.1	---
R15	---	69.3	---	59.6	---	9.8	---
R16	---	69.4	---	59.3	---	10.0	---
R17	---	68.9	---	59.6	---	9.3	---
R18	---	69.2	---	59.3	---	9.9	---
R19	---	68.3	---	59.3	---	9.0	---
R20	---	68.8	---	59.2	---	9.6	---
R21	---	69.5	---	59.9	---	9.6	---
R22	---	67.4	---	60.0	---	7.4	---
R23	---	69.5	---	59.9	---	9.6	---

U of L Receiver Name	WSDOT Receiver Name	L _{eq} (dBA) No Barrier		L _{eq} (dBA) Barrier		Insertion Loss (dBA)	
		U of L	WSDOT	U of L	WSDOT	U of L	WSDOT
E23	---	73.5	---	63.8	---	9.7	---
R24	---	69.1	---	59.6	---	9.4	---
R25	---	69.3	---	59.7	---	9.6	---
E25	---	73.2	---	63.3	---	9.9	---
R26	---	69.1	---	59.5	---	9.6	---
E26	---	73.6	---	63.2	---	10.3	---
R27	---	69.2	---	69.5	---	9.7	---
E27	---	73.8	---	63.2	---	10.5	---
R28	---	68.7	---	59.0	---	9.7	---
R29	---	69.2	---	59.6	---	9.6	---
E29	---	74.2	---	63.2	---	11.0	---
R30	---	68.8	---	59.1	---	9.6	---
R31	--	68.0	---	58.2	---	9.8	---
R32	---	69.5	---	59.7	---	9.8	---
R33	---	69.8	---	59.7	---	10.1	---
E33	---	73.7	---	62.8	---	10.9	---
R34	---	69.8	---	59.6	---	10.2	---

**TABLE XV
FOURTH AVENUE
COMPARISON OF BARRIER TYPES**

Barrier Type	Dominant Barrier Design Height	Average Insertion Loss (dBA)	Cost	Added Maintenance	Improved Aesthetics
Conventional	20'	10.4	\$538,700		
Absorptive T-top	15'	11.0	\$554,400	YES	YES
Y-top	18'	10.7	\$697,500	YES	YES
Slanted-top	20'	10.4	\$722,500	NO	YES
Single-wall Absorptive	17'	10.8	\$493,400	YES	YES

Note: Eight barrier sections (BFA-BFI) are 2 feet lower than the remaining ten barrier sections (BFJ-BFS).

**TABLE XVI
 MAGNOLIA ROAD
 COMPARISON OF BARRIER TYPES**

Barrier Type	Dominant Barrier Design Height	Average Insertion Loss (dBA)	Cost	Added Maintenance	Improved Aesthetics
Conventional	20'	9.7	\$361,700		
Absorptive T-top	13'	10.4	\$330,000	YES	YES
Y-top	18'	10.4	\$471,000	YES	YES
Slanted-top	20'	9.7	\$485,200	NO	YES
Single-wall Absorptive	16'	10.4	\$314,700	YES	YES

TABLE XVII
KENT COMMONS PLAY FIELD
COMPARISON OF BARRIER TYPES

Barrier Type	Dominant Barrier Design Height	Average Insertion Loss (dBA)	Cost	Added Maintenance	Improved Aesthetics
Conventional	19'	9.4	\$711,700		
Absorptive T-top	11'	10.2	\$590,300	YES	YES
Y-top	16'	10.0	\$843,200	YES	YES
Slanted-top	19'	9.4	\$954,700	NO	YES
Single-wall Absorptive	14'	10.1	\$572,300	YES	YES

**TABLE XVIII
SPOKANE COMMUNITY COLLEGE AREA
COMPARISON OF BARRIER TYPES**

Barrier Type	Dominant Barrier Design Height	Average Insertion Loss (dBA)	Cost	Added Maintenance	Improved Aesthetics	
1. Neighborhood Side						
Conventional	20'	9.5	\$994,100			
Absorptive T-top	13'	10.6	\$907,000	YES	YES	
Y-top	18'	10.3	\$1,294,400	YES	YES	
Slanted-top	20'	9.5	\$1,333,500	NO	YES	
Single-wall Absorptive	16'	10.3	\$864,900	YES	YES	
2. Spokane Community College Side						
Conventional	20'	9.7	\$1,173,500			
Absorptive T-top	13'	10.4	\$1,070,700	YES	YES	
Y-top	18'	10.3	\$1,527,900	YES	YES	
Slanted-top	20'	9.7	\$1,574,000	NO	YES	
Single-wall Absorptive	16'	10.2	\$1,020,900	YES	YES	
1. & 2. Both Sides of Market/Greene Alternative						
Reflective Parallel	1.	24'	8.3	\$1,193,000		
	2.	24'	7.8	\$1,408,000		
Absorptive Parallel	1.	18'	8.6	\$1,312,300	YES	YES
	2.	18'	8.5	\$1,549,000	YES	YES

Attachment 5

Noise Model Validation Summary for the Project Study Area

Exhibit 5A-1. Noise Model Validation Summary for the Portage Bay/Roanoke Neighborhood

TNM Modeling #	Monitoring #	Measured ^a	Modeled ^a	Difference (modeled - measured)
HR-1	M3	76	75	-1
HR-4	M6	63	63	0
HR-7	M7	61	63	2
HR-17	M1	59	61	2
HR-18	M2	59	59	0
HR-20	M4	57	59	2
HR-23	M5	59	59	0

^a Measured and modeled equivalent sound level (L_{eq}) in A-weighted decibels (dBA).

Exhibit 5B-1. Noise Model Validation Summary for North Capitol Hill Neighborhood

TNM Modeling #	Monitoring #	Measured ^a	Modeled ^a	Difference (modeled - measured)
CH-1	M10	72	71	-1
CH-3	M11	63	64	1
CH-9	M15	66	65	-1
CH-17	M12	60	61	1
CH-19	M13	60	61	1
CH-28	M8	67	67	0
CH-29	M9	57	59	2
CH-31	M14	56	58	2

^a Measured and modeled equivalent sound level (L_{eq}) in A-weighted decibels (dBA).



Exhibit 5C-1. Noise Model Validation Summary for Montlake Neighborhood North of SR 520

TNM Modeling #	Monitoring #	Measured ^a	Modeled ^a	Difference (modeled - measured)
MN-1	M19	67	67	0
MN-4	M25	65	66	1
MN-5	M24	68	66	-2
MN-7	M23	65	67	2
MN-11	M18	67	65	-2
MN-13	M17	63	63	0
MN-15	M20	63	62	-1
MN-18	M21	71	72	1
MN-20	M22	59	59	0

^a Measured and modeled equivalent sound level (L_{eq}) in A-weighted decibels (dBA).

Exhibit 5D-1. Noise Model Validation Summary for Montlake Neighborhood South of SR 520

TNM Modeling #	Monitoring #	Measured ^a	Modeled ^a	Difference (modeled - measured)
MS-1	M27	71	73	2
MS-3	M30	73	73	0
MS-11	M28	61	59	-2
MS-12	M31	57	56	-1
MS-13	M32	58	57	-1
MS-17	M29	69	70	1
MS-20	M26	63	65	2
MS-23	M16	64	65	1

^a Measured and modeled equivalent sound level (L_{eq}) in A-weighted decibels (dBA).



Exhibit 5E-1. Noise Model Validation Summary for the Arboretum

TNM Modeling #	Monitoring #	Measured ^a	Modeled ^a	Difference (modeled - measured)
AB-15	M33	69	70	1

^a Measured and modeled equivalent sound level (L_{eq}) in A-weighted decibels (dBA).

Exhibit 5F-1. Noise Model Validation Summary for Madison Park Neighborhood

TNM Modeling #	Monitoring #	Measured ^a	Modeled ^a	Difference (modeled - measured)
MP-2	M35	65	66	1
MP-3	M36	66	67	1
MP-9	M34	58	60	2
MP-17	M37	61	62	1

^a Measured and modeled equivalent sound level (L_{eq}) in A-weighted decibels (dBA).

Exhibit 5G-1. Noise Model Validation Summary for Laurelhurst Neighborhood

TNM Modeling #	Monitoring #	Measured ^a	Modeled ^a	Difference (modeled - measured)
LH-1	M39	58	59	1
LH-7	M38	48	49	1

^a Measured and modeled equivalent sound level (L_{eq}) in A-weighted decibels (dBA).



Exhibit 5H-1. Noise Model Validation Summary for Medina

TNM Modeling #	Monitoring #	Measured ^a	Modeled ^a	Difference (modeled - measured)
PN-1	M40	60	61	1
PN-3	M43	70	68	-2
PN-5	M45	61	61	0
PN-9	M46	63	–	N/A ^b
PS-2	M42	62	61	-1
PS-3	M44	64	65	1
PS-5	M47	72	67	-5 ^c
PS-23	M41	59	59	0
PS-25	M48	53	55	2

^a Measured and modeled equivalent sound level (L_{eq}) in A-weighted decibels (dBA).

^b Located too far (more than 1,000 feet) from SR 520 for an accurate validation.

^c Non-traffic-related noise sources distorted readings during measurement.

– = Receiver location in new highway right-of-way; therefore, no noise levels were calculated.

N/A = not applicable



Attachment 6

Capital Hill Noise Wall Review

North Capitol Hill: West Side Facing I-5

Noise impacts were identified along the west side of North Capitol Hill facing toward I-5. The impacts are mainly due to traffic noise on I-5; however, there is a new ramp from the express lanes to the SR 520 corridor, along with improvements to the existing I-5 to SR 520 ramps. Therefore, noise mitigation was considered for this area. To evaluate noise mitigation measures better, the 44 residences represented by CH-1, CH-2, and CH-28 that would exceed the noise abatement criteria (NAC) were modified to include 47 residences in the immediate area to provide an appropriate end-point for the noise walls. This was accomplished by increasing the study area to North Boston Street, and distributing the receivers along the corridor.

Two walls were evaluated for this area, one that meets the cost criteria, and a second that attempts to reduce noise levels to below the WSDOT NAC. Both noise walls begin at the west end of the 10th Avenue South Lid, and follow the right-of-way around the SR 520 ramp, transitioning to the I-5 retaining wall along Harvard Avenue East, continuing south along the I-5 retaining wall to East Boston Street.

There are several issues with installing noise walls in this location. First, the wall would need to be installed on top of an existing retaining wall, and there is concern over the ability of the retaining wall to support the required wall. Second, most of the residences along this area are located above the finish grade of Harvard Avenue East, where the base of the wall would be located, and therefore, require a wall from 22 to 30 feet high to mitigate the noise impacts fully. Third, there is concern over a logical ending point for the noise wall, which for this analysis was selected to be East Boston Street. Fourth, the major noise source for these residences is traffic on I-5, not SR 520; therefore, providing mitigation for this area would be best performed during a noise analysis for I-5, not SR 520.

Finally, any noise wall in this location that would be effective at reducing noise would also be effective at blocking views. Although the blocking of views is not normally considered in a noise study, when combined with the other issues described above, the view blockage has resulted in a recommendation to evaluate noise abatement for this segment of the highway during project final design further. However, to provide the public with a general analysis of noise walls for this area, and the potential noise benefit, two noise walls were considered and evaluated for noise reduction and cost. The first wall, while being cost effective, would not be effective at mitigating noise impact for most residences along Harvard Avenue East. The second wall, while being more effective at reducing noise and impacts, reaches heights of 30 feet, may not be constructible due to the existing retaining wall along I-5, and is not able to mitigate fully the noise impacts near the southern of the wall. Finally, the question of the wall terminus would still need to be decided, and the current analysis assumes a terminus of East Boston Street, as this is the end of the SR 520 ramps to I-5. However, ending the wall at this location results in several residences in our study area with noise levels exceeding the NAC, questioning the walls overall effectiveness. Details on these walls, including noise reduction characteristic and reasonability calculations are provided in the following



Exhibits 6-1 through 6-4. Exhibits 6-1 and 6-2 are for a noise wall that meets the WSDOT cost criteria; however, 12 residences would still exceed the WSDOT NAC, with future noise levels ranging from 66 to 72 dBA L_{eq} during peak traffic periods.

Under the taller wall, noise reductions were increased to 13 dBA at some residences. However, the wall would still leave eight residences with noise levels above the WSDOT NAC.

Based on these results, a review of the sound wall options will occur during final design with assistance from the WSDOT Noise, Energy, and Air Quality team.

Exhibit 6-1. Noise Wall Performance: Cost Effective Noise Wall (Capitol Hill)

Receiver Number	Preferred Alternative Noise Levels without Noise Wall ^{a,b}	Preferred Alternative Noise Levels with Noise Wall ^{a,b}	Noise Reduction ^a	Benefited Homes ^d	Capital Available for Mitigation ^c
Montlake South of SR 520, Along East Lake Washington Boulevard					
CH-1	68	59	9	3	\$133,920
CH-2	73	70	3	2	\$118,320
CH-13	68	65	3	6	\$267,840
CH-14	62	58	4	5	\$186,900
CH-15	64	62	2		\$0
CH-28	69	62	7	4	\$178,560
CH-28A	75	66	9	3	\$210,180
CH-28B	74	65	9	2	\$132,840
CH-28C	78	72	6	1	\$73,690
CH-28D	78	72	6	4	\$294,760
CH-28E	77	72	5	2	\$147,380
CH-29	59	59	0		\$0
CH-29A	56	57	-1		\$0
CH-29B	65	64	1		\$0
Total Available for Noise Mitigation					\$1,744,390

^a All noise levels in the exhibit are stated as L_{eq} in dBA.

^b Bold numbers throughout the exhibit indicate noise levels that approach within 1 dBA or exceed the NAC of 67 dBA L_{eq} .

^c Available mitigation capital from WSDOT criteria for cost evaluation.

^d A benefited home is any unit that would receive at 3-dBA insertion loss from the proposed mitigation measure regardless of whether that unit would have noise levels exceeding the WSDOT NAC with the project.



Exhibit 6-2. Details and Cost Analysis: Cost Effective Noise Wall (Capitol Hill)

Noise Wall Description	Heights Along Wall (ft) ^a			Length (ft) ^b	Wall Area (sq ft) ^c	Cost ^d	Available Capital ^e	Residual Capital ^f
	Min	Avg	Max					
Capitol Hill Along Harvard Avenue East	14	15	16	1,639	24,600	\$1,744,303	\$1,744,390	+\$87

^a Minimum, average, and maximum noise wall heights in feet.

^b Length of recommended noise walls in feet.

^c Total noise wall surface area in square feet.

^d Cost of noise wall based on \$53.40 per square-foot from WSDOT criteria for cost evaluation. The cost has been rounded to the nearest whole dollar. This calculation includes a "credit" for the cost savings to the project for not constructing the 4-foot noise-absorptive traffic barriers.

^e Available mitigation capital from WSDOT criteria for cost evaluation.

^f Residual mitigation capital: a positive value is within the allowable capital based on WSDOT criteria; a negative value exceeds the criteria.

Exhibit 6-3. Noise Wall Performance: Highest Insertion Loss Noise Wall (Capitol Hill)

Receiver Number	Preferred Alternative Noise Levels without Noise Wall ^{a,b}	Preferred Alternative Noise Levels with Noise Wall ^{a,b}	Noise Reduction ^a	Benefited Homes ^d	Capital Available for Mitigation ^c
Montlake South of SR 520, Along East Lake Washington Boulevard					
CH-1	68	59	9	3	\$133,920
CH-2	73	70	3	2	\$118,320
CH-13	68	65	3	6	\$267,840
CH-14	62	59	4	5	\$186,900
CH-15	64	62	2		\$0
CH-28	69	61	8	4	\$178,560
CH-28A	75	65	10	3	\$210,180
CH-28B	74	63	11	2	\$132,840
CH-28C	78	65	13	1	\$73,690
CH-28D	78	67	11	4	\$294,760
CH-28E	77	72	5	2	\$147,380
CH-29	59	59	0		\$0
CH-29A	56	57	-1		\$0
CH-29B	65	64	1		\$0
Total Available for Noise Mitigation					\$1,744.390

^a All noise levels in the exhibit are stated as Leq in dBA.

^b Bold numbers throughout the exhibit indicate noise levels that approach within 1 dBA or exceed the NAC of 67 dBA Leq.

^c Available mitigation capital from WSDOT criteria for cost evaluation.

^d A benefited home is any unit that would receive at 3-dBA insertion loss from the proposed mitigation measure regardless of whether that unit would have noise levels exceeding the WSDOT NAC with the project.



Exhibit 6-4. Details and Cost Analysis: Highest Insertion Loss Noise Wall (Capitol Hill)

Noise Wall Description	Heights Along Wall (ft) ^a			Length (ft) ^b	Wall Area (sq ft) ^c	Cost ^d	Available Capital ^e	Residual Capital ^f
	Min	Avg	Max					
Capitol Hill Along Harvard Avenue East	14	20	30	1,639	33,697	\$2,524,542	\$1,744,390	-\$780,152

^a Minimum, average, and maximum noise wall heights in feet.

^b Length of recommended noise walls in feet.

^c Total noise wall surface area in square feet.

^d Cost of noise wall based on \$53.40 per square-foot from WSDOT criteria for cost evaluation. The cost has been rounded to the nearest whole dollar. This calculation includes a "credit" for the cost savings to the project for not constructing the 4-foot noise-absorptive traffic barriers.

^e Available mitigation capital from WSDOT criteria for cost evaluation.

^f Residual mitigation capital: a positive value is within the allowable capital based on WSDOT criteria; a negative value exceeds the criteria.



Attachment 7

Comparison of Modeled Noise Levels: Preferred Alternative with Options A, K, and L

Attachment 7

Comparison of Modeled Noise Levels: Preferred Alternative with Alternatives A, K and L

Receiver Number	Residential Structures	FHWA NAC	Operational Noise Levels (dBA - peak hour Leq)						Noise level change from Preferred Alternative W/O barriers to				
			Current	No Build Alternative	Preferred Alternative W/O Safety Barriers	SDEIS Options			Option A	Option K	Option L		
						Option A	Option K	Option L					
HR-1	4	67	77	78	78	73	73	73	5	5	5		
HR-2	4	67	75	76	76	72	72	72	4	4	4		
HR-3	2	67	72	73	71	68	68	68	3	3	3		
HR-4	3	67	66	66	66	64	65	65	2	1	1		
HR-5	3	67	67	67	70	68	69	69	2	1	1		
HR-6	1	67	75	75	Receiver Displaced under all build alternatives due to roadway widening								
HR-7	2	67	64	65	64	70	70	70	-6	-6	-6		
HR-8	1	67	62	64	62	69	69	69	-7	-7	-7		
HR-9	1	67	68	67	61	65	67	67	-4	-6	-6		
HR-10	4	67	63	63	64	67	67	67	-3	-3	-3		
HR-11	4	67	56	56	63	63	63	63	0	0	0		
HR-12	4	67	63	64	65	64	65	65	1	0	0		
HR-13	5	67	64	65	65	63	64	64	2	1	1		
HR-14	3	67	67	67	68	66	66	66	2	2	2		
HR-15	3	67	74	73	74	67	67	68	7	7	6		
HR-16	1	67	64	65	65	64	64	64	1	1	1		
HR-17	3	67	63	64	64	64	64	64	0	0	0		
HR-18	4	67	61	61	62	62	62	62	0	0	0		
HR-19	4	67	61	61	61	63	64	63	-2	-3	-2		
HR-20	4	67	60	60	60	62	62	61	-2	-2	-1		
HR-21	3	67	58	57	59	61	62	62	-2	-3	-3		
HR-22	5	67	63	63	59	61	62	62	-2	-3	-3		
HR-23	6	67	61	61	59	59	59	59	0	0	0		
BH-1	3	67	63	63	59	61	62	62	-2	-3	-3		
BH-2	3	67	64	64	60	62	63	62	-2	-3	-2		
BH-3	3	67	62	62	59	59	59	59	0	0	0		
CH-1	3	67	73	73	72	71	71	72	1	1	0		
CH-2	2	67	71	71	73	71	71	71	2	2	2		
CH-3	4	67	66	66	62	62	63	62	0	-1	0		
CH-4	4	67	64	65	63	63	64	64	0	-1	-1		
CH-5	2	67	65	66	65	65	65	66	0	0	-1		
CH-6 Upper	18	67	70	72	70	69	69	69	1	1	1		
CH-6 Lower	Receiver not included in DEIS or SDEIS - added following changes in Portage Bay structure elevations												
CH-7	4	67	68	68	63	67	67	67	-4	-4	-4		
CH-8	24	67	67	66	63	66	66	66	-3	-3	-3		
CH-9	8	67	67	66	63	66	65	65	-3	-2	-2		
CH-10	1	67	64	64	63	64	64	64	-1	-1	-1		
CH-11	3	67	63	63	62	62	62	62	0	0	0		
CH-12	8	67	65	65	65	65	66	65	0	-1	0		

Attachment 7

Comparison of Modeled Noise Levels: Preferred Alternative with Alternatives A, K and L

Receiver Number	Residential Structures	FHWA NAC	Operational Noise Levels (dBA - peak hour Leq)						Noise level change from Preferred Alternative W/O barriers to		
			Current	No Build Alternative	Preferred Alternative W/O Safety Barriers	SDEIS Options			Option A	Option K	Option L
						Option A	Option K	Option L			
CH-13	6	67	69	69	69	68	68	69	1	1	0
CH-14	5	67	65	65	64	63	64	64	1	0	0
CH-15	6	67	66	66	65	65	65	65	0	0	0
CH-16	20	67	66	67	67	67	67	67	0	0	0
CH-17	6	67	63	63	63	63	63	63	0	0	0
CH-18	4	67	62	63	61	62	62	62	-1	-1	-1
CH-19	2	67	63	63	61	62	62	62	-1	-1	-1
CH-20	4	67	63	63	61	63	62	62	-2	-1	-1
CH-21	14	67	64	64	61	63	63	63	-2	-2	-2
CH-22	16	67	64	64	61	63	63	63	-2	-2	-2
CH-23	8	67	64	64	61	63	63	63	-2	-2	-2
CH-24	14	67	62	62	60	61	61	61	-1	-1	-1
CH-25	6	67	63	62	61	62	62	62	-1	-1	-1
CH-26	7	67	62	62	60	62	61	62	-2	-1	-2
CH-27	6	67	62	62	60	61	61	61	-1	-1	-1
CH-28	4	67	69	71	69	71	70	70	-2	-1	-1
CH-29	3	67	61	61	60	61	61	61	-1	-1	-1
CH-30	5	67	61	60	59	60	60	60	-1	-1	-1
CH-31	1	67	60	60	58	59	59	59	-1	-1	-1
CH-32	1	67	61	61	59	61	61	61	-2	-2	-2

Attachment 7

Comparison of Modeled Noise Levels: Preferred Alternative with Alternatives A, K and L

Receiver Number	Residential Structures	FHWA NAC	Operational Noise Levels (dBA - peak hour Leq)						Noise level change from Preferred Alternative W/O barriers to				
			Current	No Build Alternative	Preferred Alternative W/O Safety Barriers	SDEIS Options			Option A	Option K	Option L		
						Option A	Option K	Option L					
MN-1	3.3c	67	69	67	65	67	67	67	-2	-2	-2		
MN-2	3.3c	67	66	67	65	64	68	67	1	-3	-2		
MN-3	0	None	75	73	Receiver Displaced under all build alternatives due to roadway widening								
MN-4	2	67	67	67	63	67	66	65	-4	-3	-2		
MN-5	3	67	67	67	65	66	62	61	-1	3	4		
MN-6	3	67	66	68	67	64	62	62	3	5	5		
MN-7	2	67	69	74	73	69	67	67	4	6	6		
MN-8	3	67	68	71	72	70	69	69	2	3	3		
MN-9	3	67	64	66	66	63	65	64	3	1	2		
MN-10	4	67	64	64	63	63	64	63	0	-1	0		
MN-11	3.3c	67	66	65	63	65	65	65	-2	-2	-2		
MN-12	3.3c	67	65	64	62	64	64	64	-2	-2	-2		
MN-13	4	67	64	63	62	63	63	63	-1	-1	-1		
MN-14	3	67	64	63	62	63	63	63	-1	-1	-1		
MN-15	4	67	64	63	63	62	63	63	1	0	0		
MN-16	4	67	63	64	64	62	64	63	2	0	1		
MN-17	4	67	68	70	73	71	70	70	2	3	3		
MN-18	3	67	72	73	72	68	69	68	4	3	4		
MN-19	5	67	62	65	64	60	62	61	4	2	3		
MN-20	3	67	60	64	63	59	61	58	4	2	5		
MN-21	3	67	61	63	62	58	61	58	4	1	4		
MN-22	3.3c	67	63	63	63	61	65	58	2	-2	5		
MN-23	4	67	68	70	72	70	70	69	2	2	3		
MN-24	3	67	62	62	61	62	62	62	-1	-1	-1		
MN-25	2	67	63	66	65	62	64	63	3	1	2		
MN-26	2	67	72	68	71	68	68	67	3	3	4		
MN-27	3	67	65	65	66	62	63	62	4	3	4		
MN-28	6	67	60	61	62	58	60	59	4	2	3		
MN-29	3.3c	67	65	64	66	64	65	66	2	1	0		
MN-30	3.3c	67	60	60	61	58	60	under bridge	3	1	under bridge		
MN-31	4	67	59	60	61	57	59	60	4	2	1		
MN-32	2	67	62	64	65	60	61	59	5	4	6		
MN-33	1	67	64	66	67	63	62	61	4	5	6		
MN-34	1	67	66	72	69	66	66	65	3	3	4		
MN-35	2	67	63	68	67	62	63	63	5	4	4		
MS-1	4	67	74	75	75	72	68	71	3	7	4		
MS-2	4	67	74	73	70	70	70	70	0	0	0		
MS-3	6	67	74	72	67	70	72	71	-3	-5	-4		
MS-4	3	67	72	70	68	70	72	71	-2	-4	-3		

Attachment 7

Comparison of Modeled Noise Levels: Preferred Alternative with Alternatives A, K and L

Receiver Number	Residential Structures	FHWA NAC	Operational Noise Levels (dBA - peak hour Leq)						Noise level change from Preferred Alternative W/O barriers to		
			Current	No Build Alternative	Preferred Alternative W/O Safety Barriers	SDEIS Options			Option A	Option K	Option L
						Option A	Option K	Option L			
MS-5	5	67	70	68	67	69	71	71	-2	-4	-4
MS-6	4	67	59	58	59	60	60	61	-1	-1	-2
MS-7	4	67	59	58	59	61	61	61	-2	-2	-2
MS-8	3	67	61	61	62	62	63	62	0	-1	0
MS-9	2	67	62	64	65	63	63	63	2	2	2
MS-10	4	67	67	70	70	66	65	65	4	5	5
MS-11	2	67	60	62	63	60	59	59	3	4	4
MS-12	4	67	56	57	58	57	56	56	1	2	2
MS-13	4	67	58	56	58	59	59	59	-1	-1	-1
MS-14	4	67	60	59	59	61	62	62	-2	-3	-3
MS-15	6	67	56	56	58	56	54	55	2	4	3
MS-16	4	67	62	62	63	61	58	58	2	5	5
MS-17	2	67	73	72	72	69	69	69	3	3	3
MS-18	4	67	65	69	70	67	63	63	3	7	7
MS-19	4	67	66	67	67	66	65	64	1	2	3
MS-20	3	67	66	66	66	67	67	67	-1	-1	-1
MS-21	9.2c	67	70	69	66	68	69	69	-2	-3	-3
MS-22	9.2c	67	69	68	63	67	67	67	-4	-4	-4
MS-23	9.2c	67	66	66	62	65	65	65	-3	-3	-3
MS-24	2	67	63	63	60	62	62	62	-2	-2	-2
MS-25	2	67	63	63	60	62	62	62	-2	-2	-2
MS-26	4	67	63	56	56	57	57	56	-1	-1	0
MS-27	3	67	65	65	64	64	66	65	0	-2	-1
MS-28	4	67	64	65	64	65	66	65	-1	-2	-1
MS-29	4	67	63	63	63	62	62	62	1	1	1
MS-30	4	67	64	65	65	64	62	62	1	3	3
MS-31	6	67	58	56	58	59	59	60	-1	-1	-2
MS-32	4	67	61	59	60	62	63	63	-2	-3	-3
MS-33	5	67	64	62	63	65	64	65	-2	-1	-2

Attachment 7

Comparison of Modeled Noise Levels: Preferred Alternative with Alternatives A, K and L

Receiver Number	Residential Structures	FHWA NAC	Operational Noise Levels (dBA - peak hour Leq)						Noise level change from Preferred Alternative W/O barriers to		
			Current	No Build Alternative	Preferred Alternative W/O Safety Barriers	SDEIS Options			Option A	Option K	Option L
						Option A	Option K	Option L			
UW-1	2.2c	67	65	68	69	65	63	65	4	6	4
UW-2	2.2c	67	58	61	62	57	56	70	5	6	-8
UW-3	2.2c	67	55	57	58	53	54	59	5	4	-1
UW-4	2.2c	67	54	56	56	52	52	55	4	4	1
UW-5	11.2c	67	54	56	57	52	52	54	5	5	3
UW-6	3.3c	67	58	60	60	55	55	59	5	5	1
UW-7	5.6c	67	62	64	63	59	59	61	4	4	2
UW-8	5.6c	67	52	55	56	51	51	51	5	5	5
UW-9	22.3c	67	53	56	56	52	52	52	4	4	4
UW-10	5.6c	67	62	65	65	62	62	62	3	3	3
UW-11	2.2c	67	66	68	68	66	66	66	2	2	2
UW-12	2.2c	67	64	65	65	64	64	64	1	1	1
UW-13	5.4c	67	59	62	62	57	58	58	5	4	4
UW-14	2.7c	67	61	65	66	63	63	64	3	3	2
UW-15	2.2c	67	64	65	65	63	62	63	2	3	2
UW-16	5.6c	67	62	62	63	61	60	60	2	3	3
AB-1	5.4c	67	66	65	66	65	66	66	1	0	0
AB-2	5.4c	67	67	66	67	69	67	67	-2	0	0
AB-3	5.4c	67	68	68	67	70	68	69	-3	-1	-2
AB-4	0d	67	80	82	Receivers Displaced	71	70	71	Receivers Displaced		
AB-5	0d	67	76	79		70	69	69			
AB-6	0d	67	72	74	66	69	68	68	-3	-2	-2
AB-7	0d	67	70	72	67	68	67	67	-1	0	0
AB-8	0d	67	69	71	68	67	66	67	1	2	1
AB-9	0d	67	68	70	69	66	66	65	3	3	4
AB-10	0d	67	67	69	69	65	65	64	4	4	5
AB-11	0d	67	67	68	68	64	64	64	4	4	4
AB-12	0d	67	66	67	67	64	64	63	3	3	4
AB-13	0d	67	65	67	67	63	63	63	4	4	4
AB-14	5.4c	67	63	64	65	63	63	62	2	2	3
AB-15	5.4c	67	71	72	70	71	71	70	-1	-1	0
AB-16	5.4c	67	65	66	67	65	65	64	2	2	3
AB-17	5.4c	67	60	61	61	60	59	59	1	2	2
AB-18	5.4c	67	56	56	56	56	56	55	0	0	1
AB-19	5.4c	67	64	62	59	64	60	59	-5	-1	0
AB-20	5.4c	67	63	62	64	62	68	65	2	-4	-1
MP-1	3	67	66	66	65	66	66	65	-1	-1	0
MP-2	2	67	67	67	66	67	67	65	-1	-1	1
MP-3	2	67	68	68	66	67	67	66	-1	-1	0
MP-4	3	67	69	69	67	67	68	67	0	-1	0

Attachment 7

Comparison of Modeled Noise Levels: Preferred Alternative with Alternatives A, K and L

Receiver Number	Residential Structures	FHWA NAC	Operational Noise Levels (dBA - peak hour Leq)						Noise level change from Preferred Alternative W/O barriers to		
			Current	No Build Alternative	Preferred Alternative W/O Safety Barriers	SDEIS Options			Option A	Option K	Option L
						Option A	Option K	Option L			
MP-5	3	67	66	66	65	65	65	65	0	0	0
MP-6	2	67	63	63	63	62	63	62	1	0	1
MP-7	3	67	61	61	61	61	61	61	0	0	0
MP-8	3	67	60	60	59	60	60	60	-1	-1	-1
MP-9	4	67	61	61	60	61	61	61	-1	-1	-1
MP-10	16.7c	67	61	61	61	61	61	61	0	0	0
MP-11	16.7c	67	61	61	61	62	62	61	-1	-1	0
MP-12	4	67	59	59	60	60	60	61	0	0	-1
MP-13	3	67	60	60	61	60	61	62	1	0	-1
MP-14	4	67	61	61	61	61	61	62	0	0	-1
MP-15	4	67	61	61	61	61	61	62	0	0	-1
MP-16	4	67	63	63	62	62	62	63	0	0	-1
MP-17	3	67	64	64	63	63	64	63	0	-1	0
MP-18	5	67	65	65	64	64	64	64	0	0	0
MP-19	3	67	66	66	65	65	65	65	0	0	0
MP-20	3	67	64	64	64	63	63	63	1	1	1
MP-21	1	67	60	60	61	61	61	62	0	0	-1
MP-22	4	67	58	59	58	59	59	59	-1	-1	-1
MP-23	3	67	57	56	57	57	57	57	0	0	0
LH-1	2	67	61	61	62	61	61	61	1	1	1
LH-2	2	67	61	61	61	61	61	61	0	0	0
LH-3	2	67	59	60	61	60	60	60	1	1	1
LH-4	2	67	60	60	61	60	60	60	1	1	1
LH-5	2	67	53	56	55	54	54	54	1	1	1
LH-6	3	67	57	57	58	58	58	58	0	0	0
LH-7	2	67	51	56	55	53	53	54	2	2	1